

53-1001811-01  
January 31, 2010



# BigIron RX

---

## Installation Guide

Supporting BigIron RX running software release 02.7.02

53-1001811-01



## Notes, Cautions, and Warnings

---

### NOTE

A NOTE indicates important information that helps you make better use of your computer.

---



### CAUTION

See the safety and regulatory information that shipped with your system. For additional regulatory information, see the Regulatory Compliance Homepage on [www.dell.com](http://www.dell.com) at the following location: [www.dell.com/regulatory\\_compliance](http://www.dell.com/regulatory_compliance).

---



### CAUTION

A CAUTION indicates potential damage to hardware or loss of data if instructions are not followed.

---



### DANGER

A DANGER indicates a potential for property damage, personal injury, or death.

---

---

Information in this document is subject to change without notice.

© 2009 Dell Inc. All rights reserved.

Reproduction of these materials in any manner whatsoever without the written permission of Dell Inc. is strictly forbidden.

Trademarks used in this text: *Dell*, the *DELL* logo, *Inspiron*, *Dell Precision*, *Dimension*, *OptiPlex*, *Latitude*, *PowerEdge*, *PowerVault*, *PowerApp*, *Dell OpenManage* and the *YOURS IS HERE* logo are trademarks of Dell Inc.; *Intel*, *Pentium*, and *Celeron* are registered trademarks of Intel Corporation in the U.S. and other countries; *Microsoft*, *Windows*, *Windows Server*, *MS-DOS* and *Windows Vista* are either trademarks or registered trademarks of Microsoft Corporation in the United States and/or other countries.

Other trademarks and trade names may be used in this document to refer to either the entities claiming the marks and names or their products. Dell Inc. disclaims any proprietary interest in trademarks and trade names other than its own.

Regulatory Model Codes: Brocade DCX-4S, Brocade DCX

# Contents

---

## About This Document

In this chapter .....	ix
Audience .....	ix
Supported hardware and software .....	ix
Document conventions .....	ix
Text formatting .....	x
Notes, cautions, and danger notices .....	x
Notice to the reader .....	x
Related publications .....	xi
Getting technical help or reporting errors .....	xi
Web access .....	xi
E-mail access .....	xi
Telephone access .....	xi

## Chapter 1

### Product Overview

In this chapter .....	1
Product overview .....	1
Hardware features .....	2
Chassis .....	2
Management modules .....	8
Interface modules .....	10
2-port 10 Gigabit Ethernet module .....	11
16-port 10 Gigabit Ethernet oversubscribed module .....	12
Gigabit Ethernet interface module (SFP) .....	14
48-port 1 Gigabit Ethernet interface module (Mini RJ 21 Copper) .....	15
Switch fabric module .....	16
Power supplies .....	17
Cooling system .....	18
LEDs .....	22
Rack mount kit .....	22
Supported software features .....	23

## Chapter 2

### Installing a BigIron RX Series Switch

In this chapter .....	25
Installation precautions .....	25
General precautions .....	26
Power precautions .....	26

Installing a BigIron RX-4 switch .....	28
Preparing the installation site .....	29
Unpacking a BigIron RX-4 switch .....	29
Chassis lifting guidelines for BigIron RX-4 switches .....	30
Installing a BigIron RX-4 chassis in a rack .....	30
Installing BigIron RX-4 modules .....	33
Installing power supplies in a BigIron RX-4 chassis .....	35
Connecting AC power to a BigIron RX-4 chassis .....	36
Connecting DC power to a BigIron RX-4 chassis .....	36
Final steps .....	37
Installing a BigIron RX-8 switch .....	38
Preparing the installation site .....	38
Unpacking a BigIron RX-8 switch .....	38
Chassis lifting guidelines for BigIron RX-8 switches .....	39
Installing the BigIron RX-8 chassis in a rack .....	39
Installing BigIron RX-8 modules .....	42
Installing power supplies in the BigIron RX-8 chassis .....	44
Connecting AC power to a BigIron RX-8 chassis .....	45
Connecting DC power to a BigIron RX-8 chassis .....	46
Final steps .....	47
Installing a BigIron RX-16 switch .....	47
Preparing the installation site .....	47
Unpacking a BigIron RX-16 switch .....	48
Chassis lifting guidelines for BigIron RX-16 switches .....	48
Installing a BigIron RX-16 chassis in a rack .....	49
Installing BigIron RX-16 modules .....	52
Installing power supplies in a BigIron RX-16 chassis .....	54
Connecting AC power to a BigIron RX-16 chassis .....	55
Connecting DC power to a BigIron RX-16 chassis .....	56
Final steps .....	57
Installing a BigIron RX-32 switch .....	57
Preparing the installation site .....	57
Unpacking a BigIron RX-32 switch .....	58
Installing a BigIron RX-32 chassis in a rack .....	59
Installing BigIron RX-32 modules .....	62
BigIron RX-32 cable routing .....	67
Installing power supplies in a BigIron RX-32 chassis .....	75
Connecting AC power to a BigIron RX-32 chassis .....	77
Final steps .....	77
Attaching a management station .....	77
Attaching a PC or terminal to the Console port or Ethernet port .....	78
Attaching the management module's Ethernet Port to a network .....	79
Powering-on the power source .....	79
Verifying proper operation .....	80
Observing the LEDs .....	80
Displaying the module status .....	85



<b>Chapter 3</b>	<b>Using the Brocade Structured Cabling Components</b>	
	In this chapter . . . . .	89
	Cable Cinch overview . . . . .	89
	mRJ-21 procedures . . . . .	90
	Cable Cinch with two mRJ-21 cables . . . . .	90
	Cable Cinch with three mRJ-21 cables . . . . .	91
	Cable Cinch with four mRJ-21 cables . . . . .	91
	Cable Cinch with five mRJ-21 cables . . . . .	92
	Cable Cinch with six mRJ-21 cables . . . . .	92
	Cable Cinch with seven mRJ-21 cables . . . . .	93
	Cable Cinch with eight mRJ-21 cables . . . . .	93
	RJ-45 procedures . . . . .	94
	Cable Cinch with one group of RJ-45 cables . . . . .	94
	Cable Cinch with two groups of RJ-45 cables . . . . .	94
	Cable Cinch with three groups of RJ-45 cables . . . . .	95
	Cable Cinch with four groups of RJ-45 cables . . . . .	95
	Cable Cinch with five groups of RJ-45 cables . . . . .	96
	Cable Cinch with six groups of RJ-45 cables . . . . .	96
	Cable Cinch with seven groups of RJ-45 cables . . . . .	97
	Cable Cinch with eight groups of RJ-45 cables . . . . .	97
<b>Chapter 4</b>	<b>Connecting a BigIron RX Series Switch to a Network Device</b>	
	In this chapter . . . . .	99
	Assigning passwords . . . . .	99
	Configuring IP addresses . . . . .	102
	Support of sub-net masks . . . . .	102
	Assigning an IP address to a management interface . . . . .	102
	Assigning an IP address to an interface, virtual Interface, or loopback . . . . .	103
	Enabling and disabling the interfaces . . . . .	104
	Understanding how the management port functions . . . . .	105
	Connecting a BigIron RX Series switch . . . . .	105
	Installing a fiber optic module . . . . .	106
	Cabling a fiber optic module . . . . .	107
	Enhanced Digital Optical Monitoring . . . . .	107
	Cleaning fiber optic modules . . . . .	108
	Troubleshooting network connections . . . . .	109
	Testing network connectivity . . . . .	110
	Pinging an IP address . . . . .	110
	Tracing a route . . . . .	110
	Using virtual cable testing to diagnose a cable . . . . .	111
<b>Chapter 5</b>	<b>Managing the BigIron RX Series Chassis and Modules</b>	
	In this chapter . . . . .	113

Managing the BigIron RX Series chassis . . . . .	113
Displaying chassis status and temperature readings . . . . .	113
Displaying the Syslog configuration and static and dynamic buffers . . . . .	115
Managing the cooling system . . . . .	117
Configuring the cooling system . . . . .	117
Manually setting the fan speed . . . . .	121
Monitoring the cooling system . . . . .	122
Managing the interface modules . . . . .	123
Configuring interface module boot parameters . . . . .	123
Synchronizing the interface module's IronWare images between management and interface modules . . . . .	123
Specifying an immediate boot . . . . .	125
Changing priority of chassis slots for interface modules . . . . .	129
Disabling and reenabling power to the interface modules . . . . .	130
Disabling and reenabling power to the switch fabric modules . . . . .	130
Enabling and disabling management module CPU usage calculations . . . . .	131
Displaying management module CPU usage . . . . .	132
Enabling and disabling packet logging for management and interface modules . . . . .	133
Displaying a packet log . . . . .	134
Removing MAC address entries . . . . .	135

## Chapter 6

### Maintaining a BigIron RX Series Switch

In this chapter . . . . .	137
Replacing a management module . . . . .	137
Removing a management module . . . . .	138
Installing a new management module . . . . .	139
Replacing an interface module . . . . .	139
Removing an interface module . . . . .	140
Installing a new interface module . . . . .	141
Replacing a switch fabric module . . . . .	143
Removing a switch fabric module . . . . .	144
Installing a new switch fabric module . . . . .	144
Replacing a fiber-optic transceiver . . . . .	145
Removing a fiber-optic transceiver . . . . .	145
Installing a new fiber-optic transceiver . . . . .	146
Cabling a fiber-optic transceiver . . . . .	146
Replacing a power supply . . . . .	147
Determining which power supply failed . . . . .	147
Replacing a power supply . . . . .	147

Replacing cooling system components . . . . .	150
Replacing fan assemblies in the BigIron RX- 32 . . . . .	150
Replacing fan assemblies in the BigIron RX-16 . . . . .	153
Replacing the fan assembly in the BigIron RX-4 and BigIron RX-8 . . . . .	155
Replacing the air filters in a BigIron RX Series switch . . . . .	158

## Chapter 7

### Upgrading Software Images and Configuration Files

In this chapter . . . . .	163
Software images required . . . . .	163
Software image naming conventions . . . . .	165
Displaying flash memory and version information . . . . .	166
Displaying flash information . . . . .	166
Displaying version information . . . . .	171
Upgrading the BigIron RX Series software . . . . .	174
Changes to software images starting with version 02.5.00 . . . . .	174
Command change . . . . .	176
Unified software image upgrade to upgrade release 02.6.00 and later . . . . .	177
Unified software image upgrade to upgrade release 02.2.01 to 02.5.00 . . . . .	178
Upgrading software releases prior to release 02.2.01 . . . . .	179
Basic tasks in the software upgrade process . . . . .	179
Upgrading the management module's monitor and boot images . . . . .	180
Upgrading the management module's IronWare image . . . . .	180
Upgrading the interface module's monitor and boot images . . . . .	181
Upgrading the interface module's IronWare image . . . . .	182
Rebooting the management module . . . . .	183
Upgrading the MBRIDGE FPGA on the management module . . . . .	183
Hitless Layer 2 OS upgrade . . . . .	185
Loading and saving configuration files . . . . .	189
Replacing the startup configuration with the running configuration . . . . .	190
Replacing the running configuration with the startup configuration . . . . .	190
Logging changes to the startup-config file . . . . .	190
Copying a configuration file to or from a TFTP server . . . . .	190
Making local copies of the startup configuration file . . . . .	191
Dynamic configuration loading . . . . .	191
Loading the configuration information into the running-config . . . . .	193
Using SNMP to save and load configuration information . . . . .	194
Erasing image and configuration files . . . . .	195
File synchronization . . . . .	195
File synchronization between the active and standby management modules . . . . .	195
File synchronization between the management and interface modules . . . . .	196

	Scheduling a system reload . . . . .	198
	Reloading at a specific time . . . . .	198
	Reloading after a specific amount of time. . . . .	198
	Displaying the amount of time remaining before a scheduled reload . . . . .	199
	Canceling a scheduled reload. . . . .	199
	Diagnostic error codes and remedies for TFTP transfers. . . . .	199
<b>Chapter 8</b>	<b>Hardware Specifications</b>	
	In this chapter . . . . .	201
	Hardware specifications. . . . .	201
	Power specifications . . . . .	201
	Physical dimensions . . . . .	203
	Operating environment . . . . .	204
	Storage environment . . . . .	204
	Safety agency approvals . . . . .	204
	Electromagnetic approvals . . . . .	204
	Port specifications . . . . .	205
	Console port pin assignments . . . . .	205
	Management port pin assignments . . . . .	206
<b>Appendix A</b>	<b>Regulatory Statements</b>	
	U.S.A. . . . .	207
	Industry Canada statement . . . . .	207
	Europe and Australia. . . . .	207
	Japan . . . . .	207
	Korea . . . . .	208
<b>Appendix B</b>	<b>Caution and Danger Notices</b>	
	Caution statements. . . . .	209
	Danger notices . . . . .	216
<b>Appendix C</b>	<b>Software Specifications</b>	
	IEEE compliance . . . . .	223
	RFC support. . . . .	223
	General protocols. . . . .	223
	BGP. . . . .	224
	OSPF. . . . .	224
	RIP. . . . .	225
	IP Multicast. . . . .	225
	Management . . . . .	225
	Internet drafts . . . . .	226

# About This Document

---

## In this chapter

- Audience. . . . . ix
- Supported hardware and software. . . . . ix
- Document conventions . . . . . ix
- Notice to the reader . . . . . x
- Related publications . . . . . xi
- Getting technical help or reporting errors . . . . . xi

## Audience

This document is designed for system administrators with a working knowledge of Layer 2 and Layer 3 switching and routing.

If you are using a Brocade Layer 3 Switch, you should be familiar with the following protocols if applicable to your network – IP, RIP, OSPF, BGP, ISIS, IGMP, PIM, DVMRP, and VRRP.

## Supported hardware and software

The following hardware platforms are supported by this release of this guide:

- BigIron RX - 4
- BigIron RX - 8
- BigIron RX - 16
- BigIron RX - 32

## Document conventions

This section describes text formatting conventions and important notice formats used in this document.

## Text formatting

The narrative-text formatting conventions that are used are as follows:

<b>bold text</b>	Identifies command names Identifies the names of user-manipulated GUI elements Identifies keywords Identifies text to enter at the GUI or CLI
<i>italic text</i>	Provides emphasis Identifies variables Identifies document titles
code text	Identifies CLI output

For readability, command names in the narrative portions of this guide are presented in bold: for example, **show version**.

## Notes, cautions, and danger notices

The following notices and statements are used in this manual. They are listed below in order of increasing severity of potential hazards.

---

### NOTE

A note provides a tip, guidance or advice, emphasizes important information, or provides a reference to related information.

---



### CAUTION

**A Caution statement alerts you to situations that can be potentially hazardous to you or cause damage to hardware, firmware, software, or data.**

---



### DANGER

***A Danger statement indicates conditions or situations that can be potentially lethal or extremely hazardous to you. Safety labels are also attached directly to products to warn of these conditions or situations.***

---

## Notice to the reader

This document may contain references to the trademarks of the following corporations. These trademarks are the properties of their respective companies and corporations.

These references are made for informational purposes only.

Corporation	Referenced trademarks and products
Phillips Screw Company, Inc	Phillips

## Related publications

The following Brocade documents supplement the information in this guide:

- BigIron RX Series Configuration Guide.
- IronView MIB Reference Manual.
- IronView Network Manager User Guide.

---

### NOTE

For the latest edition of these documents, which contain the most up-to-date information, refer to Product Manuals at [kp.foundrynet.com](http://kp.foundrynet.com).

---

## Getting technical help or reporting errors

Brocade is committed to ensuring that your investment in our products remains cost-effective. If you need assistance, or find errors in the manuals, contact Brocade using one of the following options:

### Web access

Go to [kp.foundrynet.com](http://kp.foundrynet.com) and log in to the Knowledge Portal (KP) to obtain more information about a product, or to report documentation errors. **To report errors, click on Cases > Create a New Ticket.** Make sure you specify the document title in the ticket description.

### E-mail access

Send an e-mail to [IPsupport@brocade.com](mailto:IPsupport@brocade.com)

### Telephone access

United States and Canada: 800-752-8061

International: +800-ATFIBREE (+800 28 34 27 33)

Refer to the Services & Support page on [www.brocade.com](http://www.brocade.com) for additional toll-free numbers that may be available within your country.

Areas unable to access 800 numbers: +1-408-333-6061





# Product Overview

---

## In this chapter

- [Product overview](#) ..... 1
- [Hardware features](#) ..... 2
- [Supported software features](#) ..... 23

## Product overview

The BigIron RX Series switch provides high-performance L2/3 switching for the Enterprise, large data centers, and grid computing topologies.

The BigIron RX Series switch provides the following benefits:

- 240 Gbps full-duplex capacity per full slot and over 1.92 Terabit switching capacity for wire-speed, non-blocking switching and routing of up to 1.14 Bpps throughput capacity.
- Non-blocking 10 GbE and 1 GbE port density of up to 64 non-blocking 10 Gigabit Ethernet or 384 Gigabit Ethernet ports within a 16-slot chassis and up to 192 10 Gigabit Ethernet or 1,152 Gigabit Ethernet ports in a standard 7-foot Telco rack.
- Ultra-low latency routing of up to 512,000 IPv4 routes in hardware.
- Support for a comprehensive set of standards-based routing protocols including RIP, IS-IS, BGP4, and OSPF.
- Foundry Direct Routing (FDR) with rule-based ACLs provide wire-speed forwarding, filtering and accelerated convergence.
- End-to-end QoS delivery with Advanced Bandwidth Management (ABM) features.
- The High availability (redundancy) of the following BigIron RX Series critical components are:
  - Redundant management modules with Hitless Management Failover (HMF)
  - Redundant switch fabric elements
  - Redundant fans
  - Interface modules with hot-pleadable optics
  - Hot-swappable power supplies
- 80 Gbps of cross-module link aggregation based on 802.3ad for reliant bandwidth scalability between any two BigIron RX Series 10 Gigabit Ethernet switches.
- Built-in sFlow™ technology (RFC 3176) delivers scalable network monitoring, accounting and billing at 10 Gbps speed using Layer 2-7 per-port information, offering detailed capacity planning and security analysis solutions.
- A management (10/100/1000BaseTX Ethernet) port that can provide connectivity to your existing management network.

## Hardware features

The BigIron RX Series switches are composed of the following major hardware components:

- Chassis
- Management modules
- Interface modules
- Switch fabric module
- Power supplies
- Cooling system, which is composed of temperature sensors, fans, and fan control modules
- Rack mount kit

The following sections provide more information about these components.

### Chassis

The BigIron RX Series chassis consists of the following four chassis:

- BigIron RX-4: Provides 4 interface slots
- BigIron RX-8: Provides 8 interface slots
- BigIron RX-16: Provides 16 interface slots
- BigIron RX-32: Provides 32 interface slots

The following figures illustrate the BigIron RX Series chassis:

**FIGURE 1** BigIron RX-4 chassis

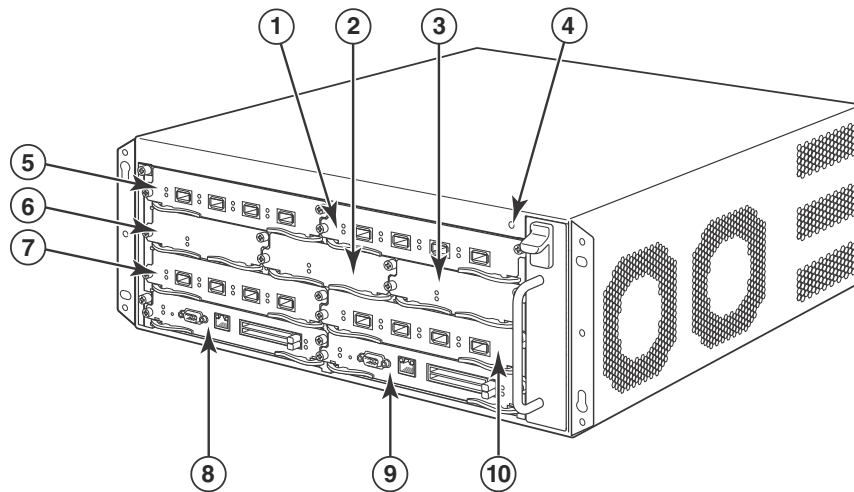

- |   |                      |    |                      |
|---|----------------------|----|----------------------|
| 1 | Interface slot 2     | 6  | Switch fabric slot 1 |
| 2 | Switch fabric slot 2 | 7  | Interface slot 3     |
| 3 | Switch fabric slot 3 | 8  | Management slot 1    |
| 4 | ESD connector        | 9  | Management slot 2    |
| 5 | Interface slot 1     | 10 | Interface slot 4     |

FIGURE 2 BigIron RX-8 chassis

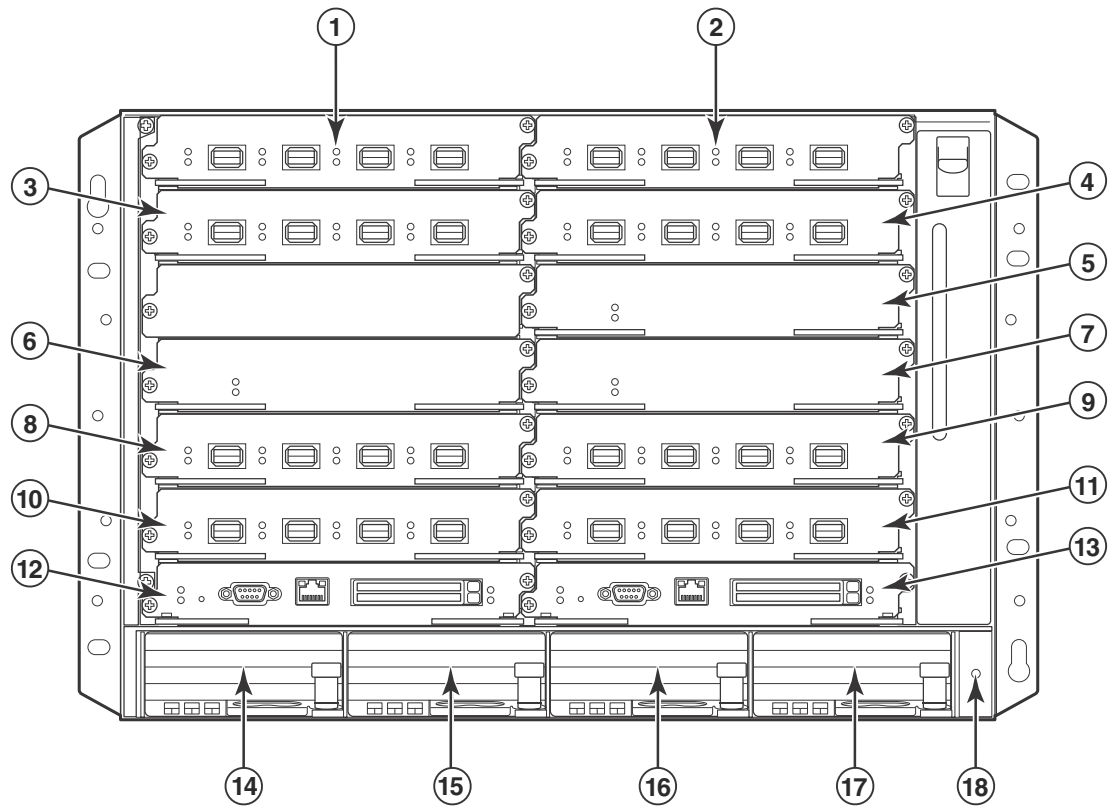

- |   |                      |    |                     |
|---|----------------------|----|---------------------|
| 1 | Interface slot 1     | 10 | Interface slot 7    |
| 2 | Interface slot 2     | 11 | Interface slot 8    |
| 3 | Interface slot 3     | 12 | Management slot 1   |
| 4 | Interface slot 4     | 13 | Management slot 2   |
| 5 | Switch fabric slot 1 | 14 | Power supply slot 1 |
| 6 | Switch fabric slot 2 | 15 | Power supply slot 2 |
| 7 | Switch fabric slot 3 | 16 | Power supply slot 3 |
| 8 | Interface slot 5     | 17 | Power supply slot 4 |
| 9 | Interface slot 6     | 18 | ESD connector       |

# 1 Hardware features

**FIGURE 3** BigIron RX-16 chassis

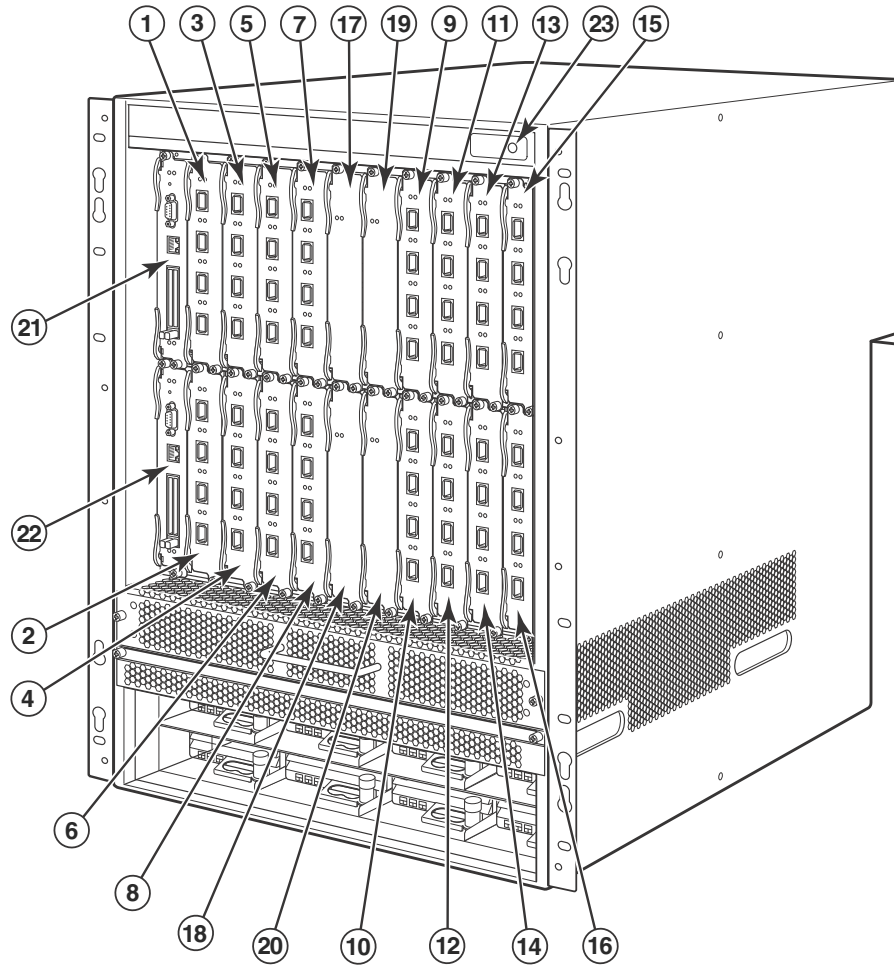

- |    |                   |    |                      |
|----|-------------------|----|----------------------|
| 1  | Interface slot 1  | 13 | Interface slot 13    |
| 2  | Interface slot 2  | 14 | Interface slot 14    |
| 3  | Interface slot 3  | 15 | Interface slot 15    |
| 4  | Interface slot 4  | 16 | Interface slot 16    |
| 5  | Interface slot 5  | 17 | Switch fabric slot 1 |
| 6  | Interface slot 6  | 18 | Switch fabric slot 2 |
| 7  | Interface slot 7  | 19 | Switch fabric slot 3 |
| 8  | Interface slot 8  | 20 | Switch fabric slot 4 |
| 9  | Interface slot 9  | 21 | Management slot 1    |
| 10 | Interface slot 10 | 22 | Management slot 2    |
| 11 | Interface slot 11 | 23 | ESD connector        |
| 12 | Interface slot 12 |    |                      |

FIGURE 4 BigIron RX-32 chassis

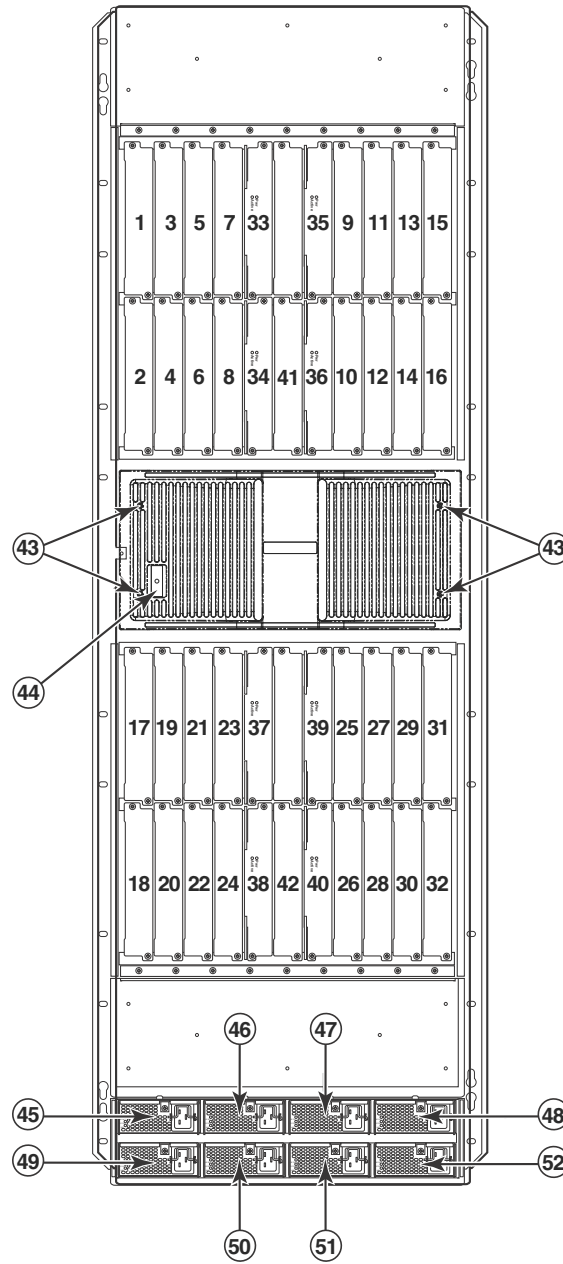

- |   |                  |    |                   |    |                      |
|---|------------------|----|-------------------|----|----------------------|
| 1 | Interface slot 1 | 19 | Interface slot 19 | 37 | Switch fabric slot 5 |
| 2 | Interface slot 2 | 20 | Interface slot 20 | 38 | Switch fabric slot 6 |
| 3 | Interface slot 3 | 21 | Interface slot 21 | 39 | Switch fabric slot 7 |
| 4 | Interface slot 4 | 22 | Interface slot 22 | 40 | Switch fabric slot 8 |
| 5 | Interface slot 5 | 23 | Interface slot 23 | 41 | Management slot 1    |
| 6 | Interface slot 6 | 24 | Interface slot 24 | 42 | Management slot 2    |
| 7 | Interface slot 7 | 25 | Interface slot 25 | 43 | Captive screws       |

# 1 Hardware features

8	Interface slot 8	26	Interface slot 26	44	ESD strap connector
9	Interface slot 9	27	Interface slot 27	45	Power supply 1
10	Interface slot 10	28	Interface slot 28	46	Power supply 2
11	Interface slot 11	29	Interface slot 29	47	Power supply 3
12	Interface slot 12	30	Interface slot 30	48	Power supply 4
13	Interface slot 13	31	Interface slot 31	49	Power supply 5
14	Interface slot 14	32	Interface slot 32	50	Power supply 6
15	Interface slot 15	33	Switch fabric slot 1	51	Power supply 7
16	Interface slot 16	34	Switch fabric slot 2	52	Power supply 8
17	Interface slot 17	35	Switch fabric slot 3		
18	Interface slot 18	36	Switch fabric slot 4		

## ***BigIron RX-4***

Upon shipment from the factory, the following components are installed in the BigIron RX-4 chassis as described:

- Two switch fabric modules.
- A slot blank in each interface module slot. The slot blank covers a slot that does not currently have a module installed in it, ensuring proper airflow within the chassis.
- A fan tray assembly, which is located in the front right side of the chassis. For more information about the fans, refer to [“Cooling system”](#) on page 18.
- One power supply (AC or DC).

In the slots of the chassis you can install the following:

- Up to two management modules (one active and one redundant).
- Up to three switch fabric modules.
- Up to four interface modules.
- Up to three power supplies (AC or DC).

Before installing any modules or power supplies, you must remove the slot blank or blank power supply faceplate, respectively.

## ***BigIron RX-8***

Upon shipment from the factory, the following components are installed in the BigIron RX-8 chassis as described:

- Two switch fabric modules.
- A slot blank in each interface module slot. The slot blank covers a slot that does not currently have a module installed in it, ensuring proper airflow within the chassis.
- A fan tray assembly, which is located in the front right side of the chassis. For more information about the fans, refer to [“Cooling system”](#) on page 18.
- Two power supplies (AC or DC).

In the slots of the chassis you can install the following:

- Up to two management modules (one active and one redundant).

- Up to three switch fabric modules.
- Up to eight interface modules.
- Up to four power supplies (AC or DC).

Before installing any modules or power supplies, you must remove the slot blank or blank power supply faceplate, respectively.

### ***BigIron RX-16***

Upon shipment from the factory, the following components are installed in the BigIron RX-16 chassis as described:

- Three switch fabric modules.
- A slot blank in each interface module slot. The slot blank covers a slot that does not currently have a module installed in it, ensuring proper airflow within the chassis.
- A fan tray assembly located in the front right side of the chassis. and two fan assemblies located at the rear of the chassis. For more information about the fans, refer to [“Cooling system”](#) on page 18.
- Four power supplies.

In the slots of the chassis you can install the following:

- Up to two management modules (one active and one redundant).
- Up to four switch fabric modules.
- Up to sixteen interface modules.
- Up to eight power supplies (AC or DC).

### ***BigIron RX-32***

Upon shipment from the factory, the following components are installed in the BigIron RX-32 chassis as described:

- One management module (shipped separately).
- Eight switch fabric modules (shipped separately).
- A slot blank in each interface module slot. The slot blank covers a slot that does not currently have a module installed in it, ensuring proper airflow within the chassis.
- Ten fan assemblies located at the rear of the chassis, four for the upper card cage, four for the lower card cage, and two for the power supplies.
- Five AC power supplies.

In the slots of the chassis you can install the following:

- Two management modules.
- Eight switch fabric modules.
- Up to 32 interface modules.
- Up to eight AC power supplies.

Before installing any modules or power supplies, you must remove the slot blank or blank power supply faceplate, respectively (BigIron RX-4, -8, and 16). On the BigIron RX-32, before installing any modules, you must remove the shipping panels covering the upper and lower card cages.



## CAUTION

**If you do not install a module in a slot, you must keep the slot blank in place. If you run the chassis with an uncovered slot, the system may overheat.**

Figure 1, Figure 2, Figure 3, and Figure 4 show the BigIron RX Series chassis and the slots into which you install the various modules. You must install the primary power supplies and the redundant power supplies as described in the figures.

Figure 1, Figure 2, Figure 3, and Figure 4 also show an electrostatic discharge (ESD) connector, into which you can plug an ESD wrist strap to ground yourself while handling and installing modules.



## DANGER

***For safety reasons, the ESD wrist strap should contain a 1 meg ohm series resistor.***

The BigIron RX-16 and BigIron RX-32 chassis versions also include a grounding lug connector, located on the rear panel (left side). The BigIron RX-4 and BigIron RX-8 have two threaded holes on the right side of the chassis to accommodate the addition of a ground lug connector.

## Management modules

The management module controls the BigIron RX Series hardware components, runs the networking protocols, and provides the Real Time Operating System (RTOS).

Each BigIron RX Series chassis requires one management module and can accept a second one for redundancy. A redundant management module works along with the active management module. If the active module becomes unavailable, the redundant management module automatically takes over the system operation, minimizing system downtime.

You can install management modules in dedicated slots marked M1 and M2. By default, the system considers the module installed in the slot marked M1 to be the active management module.

The BigIron RX-32 chassis uses a different management module than any of the other Brocade products. You cannot use management modules designed for the BigIron RX-32 in any of the other BigIron RX Series chassis or management modules designed for the BigIron RX-4, BigIron RX-8 or BigIron RX-16 in the BigIron RX-32 chassis.

---

## NOTE

The BigIron RX Series management module is dedicated, which means that you must install it in the BigIron RX Series chassis only. If you attempt to install the BigIron RX Series management module in another Brocade chassis or a management module intended for another Brocade chassis in the BigIron RX Series chassis, the chassis and module will not function properly.

Additionally, the BigIron RX-32 chassis uses a different management module than any of the other BigIron RX Series chassis. You cannot use management modules designed for the BigIron RX-32 in any of the other Brocade device, because it will not function properly.

---

A management module is hot swappable, which allows you to remove and replace it without powering down the system.



Figure 5 shows the management module's front panel.

**FIGURE 5** Management module front panel

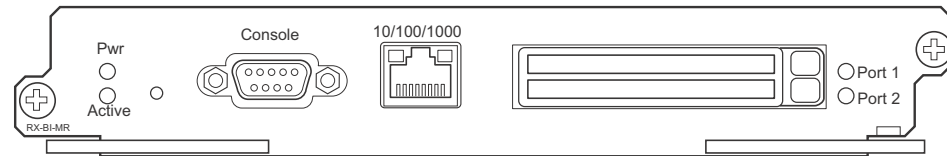

The front panel includes the following control features:

- Two PCMCIA slots
- A Console port
- A 10/100/1000 Ethernet port
- Six LEDs

### ***PCMCIA slots***

The PCMCIA slots support a flash PC card. The flash PC card provides storage space in addition to the system's flash memory. A flash PC card can store system files, including boot images, startup configuration files, running configuration files, and so on. As a result, you can perform system management tasks, such as copying files between flash PC cards, copying files between a flash PC card and flash memory, and so on.

### ***Console port***

The Console port is a standard DB-9 serial connector through which you can attach a PC or terminal to configure the BigIron RX Series system using the command line interface (CLI).

This port interfaces the control plane only and not the data plane.

### ***10/100/1000 Ethernet port***

The front panel includes a 10BaseT/100BaseTX/1000BaseTX auto-sensing, auto-negotiating Ethernet port. This port has an RJ-45 unshielded twisted pair (UTP) connector.

Typical uses of this port include but are not limited to the following:

- Connecting a PC through which you can access the system through a Telnet or SSHv2 connection and configure, monitor, and manage the BigIron RX Series system.
- Connecting to the 10BaseT/100BaseTX/1000BaseTX port of a switch or router, for connectivity to your existing management network. You can then access the BigIron RX Series system and configure, monitor, and manage the system from a management station.

---

#### **NOTE**

The existing management network into which you can connect the 10/100/1000 Ethernet port must be separate and isolated from the network over which user packets are switched and routed.

---

This port interfaces the control plane only and not the data plane.

# 1 Hardware features

## LEDs

Table 1 describes the LEDs on the management module's front panel.

**TABLE 1** Management module LEDs

LED	Position	State	Meaning
Port 1 and Port 2	Each adjacent to the PCMCIA slot that is represents	On or blinking	You have inserted a PCMCIA flash card in a slot or initiated a task related to the file management system on a flash card. As a result, the software is currently accessing the flash card.
		Off	The software is not currently accessing a PCMCIA flash card inserted in a slot.
Active	Lower Left	On	The module is functioning as the active management module.
		Off	The module is functioning as the redundant management module.
Pwr	Upper Left	On	The module is receiving power.
		Off	The module is not receiving power.
10/100/100 Ethernet Port	Above and right of RJ-45 connector	On (Green)	A link is established with the remote port.
		Off	A link is not established with the remote port.
10/100/100 Ethernet Port	Above and left of RJ-45 connector	On or blinking (Yellow)	The port is transmitting and receiving packets.
		Off for an extended period	The port is not transmitting or receiving packets.

## Interface modules

You can install up to 32 BigIron RX Series interface modules in the BigIron RX Series chassis as described:

- BigIron RX-4: Supports up to 4 interface modules
- BigIron RX-8: Supports up to 8 interface modules
- BigIron RX-16: Supports up to 16 interface modules
- BigIron RX-32: Supports up to 32 interface modules

### NOTE

A BigIron RX Series interface module is dedicated, which means that you must install it in the BigIron RX Series chassis only. If you attempt to install a BigIron RX Series interface module in another Brocade chassis or an interface module intended for another Brocade chassis in the BigIron RX Series chassis, the module will not boot up to become active. Interface modules can be shared between BigIron RX-4, BigIron RX-8, BigIron RX-16, and BigIron RX-32.

The interface modules are hot swappable, which means you can remove and replace them without powering down the system.

## 2-port 10 Gigabit Ethernet module

Figure 6 shows the 2-port 10 Gigabit Ethernet module's front panel with XFP modules installed.

FIGURE 6 2-port 10 Gigabit Ethernet module front panel

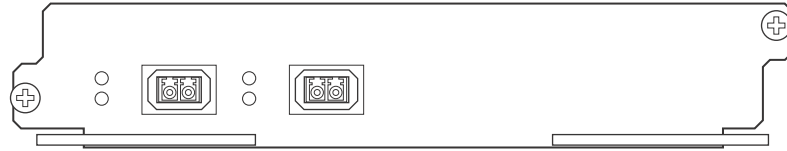

The front panel includes the following control features:

- Four LEDs
- Two 10 Gigabit Ethernet XFP slots

### LEDs

The module's front panel includes two LEDs that indicate the status of each port.

Table 2 describes the LEDs on the 10 Gigabit Ethernet module's front panel.

TABLE 2 10 Gigabit Ethernet module LEDs

LED	Position	State	Meaning
Link	Left of each Ethernet port	On	A link is established with the remote port.
		Off	A link is not established with the remote port.
Active	Left of each Ethernet port	On or blinking	The port is transmitting and receiving packets.
		Off for an extended period	The port is not transmitting or receiving packets.

A two 10 Gigabit Ethernet module contain two physical ports, through which you can connect your BigIron RX Series switch to other network devices at a speed of 10 Gigabits.

Into a physical port, you must insert a fiber-optic module provided by Brocade. The XFP-compliant fiber-optic modules provide an optical transceiver or physical medium dependent (PMD) interface for single mode fiber that can be used with the LAN physical layer (PHY).

The following optic modules versions are available from Brocade:

- Short wavelength (86 – 300 meters) – Brocade part number 10G-XFP-SR
- Long wavelength (10 kilometers) – Brocade part number 10G-XFP-LR
- Extra long wavelength (40 kilometers) – Brocade part number 10G-XFP-E=The front panel includes the following control features:
- Eight LEDs
- Four 10 Gigabit Ethernet XFP slots

### LEDs

The module's front panel includes two LEDs that indicate the status of each port.

Table 3 describes the LEDs on the 10 Gigabit Ethernet module's front panel.

**TABLE 3 10 Gigabit Ethernet module LEDs**

LED	Position	State	Meaning
Link	Left of each Ethernet port	On	A link is established with the remote port.
		Off	A link is not established with the remote port.
Active	Left of each Ethernet port	On or blinking	The port is transmitting and receiving packets.
		Off for an extended period	The port is not transmitting or receiving packets.

## 10 Gigabit Ethernet ports

A 10 Gigabit Ethernet module contains four physical ports, through which you can connect your BigIron RX Series switch to other network devices at a speed of 10 Gigabits.

Into a physical port, you must insert a fiber optic module provided by Brocade. The XFP-compliant fiber optic modules provide an optical transceiver or physical medium dependent (PMD) interface for single mode fiber that can be used with the LAN physical layer (PHY).

The following optic modules versions are available from Brocade:

- Short wavelength (86 – 300 meters) – Brocade part number 10G-XFP-SR
- Long wavelength (10 kilometers) – Brocade part number 10G-XFP-LR
- Extra long wavelength (40 kilometers) – Brocade part number 10G-XFP-ER

## 16-port 10 Gigabit Ethernet oversubscribed module

The 16 x 10GE oversubscribed module for the BigIron RX plugs into any port slot of the BigIron switch and is compatible with all previous generations of card on that switch. It provides interfaces to 16 X 10GE ports.

Figure 7 shows the 16-port 10 Gigabit Ethernet module's front panel.

**FIGURE 7 16-port 10 Gigabit Ethernet module front panel**

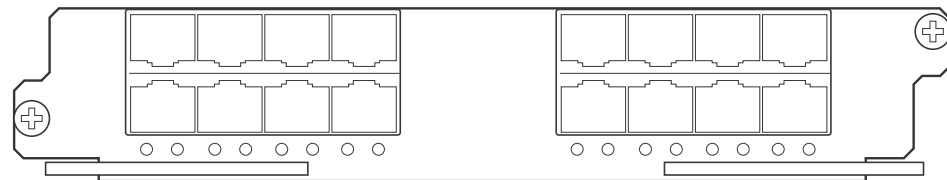

The front panel includes the following control features:

- 16 LEDs
- 16 x 10 Gigabit Ethernet XFP slots

### LEDs

The module's front panel includes 16 LEDs that indicate the status of each port.

Table 4 describes the LEDs on the 10 Gigabit Ethernet module's front panel.

**TABLE 4 10 Gigabit Ethernet module LEDs**

LED	Position	State	Meaning
Link	Below each Ethernet port	On	A link is established with the remote port.
		Off	A link is not established with the remote port.
Active	Below each Ethernet port	On or blinking	The port is transmitting and receiving packets.
		Off for an extended period	The port is not transmitting or receiving packets.

The following optic modules versions are available from Brocade:

- Short wavelength (86 – 300 meters) – Brocade part number 10G-XFP-SR
- Long wavelength (10 kilometers) – Brocade part number 10G-XFP-LR
- Extra long wavelength (40 kilometers) – Brocade part number 10G-XFP-E=The front panel includes the following control features:
- 16 LEDs
- 16 x 10 Gigabit Ethernet XFP slots

### BigIron RX -16

- The **BigIron RX -16** requires upgrading of the rear fan modules to NI-X-16-FAN-EXH-A modules. If the BigIron RX -16 is not upgraded to support NI-X-16-FAN-EXH-A modules when 16x10G modules are in the BigIron RX system, then the following syslog message will display:

```
SYSLOG: Mar 26 14:19:53:<12>R1, 48X1G modules in slots 10,11,13,16 shouldn't be running without high speed fans.
```

This message will display at the time of bootup, or when the 1Gx48-T module is inserted in the NetIron system.

---

#### NOTE

Syslog messages and traps are generated.

---

- This module is not shipped by default with the NetIron MLX-16. Please contact Brocade for purchasing this module.

### Hardware limitations

- Mirror (analyzer) ports cannot be assigned to the 16x10 card. You can monitor traffic on 16x10 ports.
- Brocade currently only support "strict" and "destination-weighted" scheduling schemes (qos scheduler). Refer to the *Configuring QoS* chapter in the *BigIron RX Configuration Guide* for more informaton.

### 10 Gigabit Ethernet ports

A 16 x 10 Gigabit Ethernet module contain 16 physical ports, through which you can connect the BigIron RX Series switch to other network devices at a speed of 10 Gigabits.

You must insert a fiber optic module provided by Brocade into a physical port. The XFP-compliant fiber optic modules provide an optical transceiver or physical medium dependent (PMD) interface for single mode fiber that can be used with the LAN physical layer (PHY).

# 1 Hardware features

The following optic modules versions are available from Brocade:

- Short wavelength (86 – 300 meters) – Brocade part number 10G-XFP-SR
- Long wavelength (10 kilometers) – Brocade part number 10G-XFP-LR
- Extra long wavelength (40 kilometers) – Brocade part number 10G-XFP-ER

## Gigabit Ethernet interface module (SFP)

The 24-port 1 Gigabit Ethernet mini-GBIC (or SFP) is auto-sensing, auto-negotiating Ethernet port and will select the FE or GE mode of operation based on the link signal received.

---

### NOTE

The device will be FE or GE capable, but will only display that is GE to indicate the maximum speed capability of the module.

---

### NOTE

The actual speed will be displayed once the link is seen and the port auto-senses the speed of the SFP.

---

You can issue the **show media** command to display the type of optic installed and determine the speed the port will run at when the link is received.

Figure 8 shows the 24-port 1 Gigabit Ethernet mini-GBIC (or SFP) module's front panel.

**FIGURE 8** 24-port 1 Gigabit Ethernet SFP module front panel

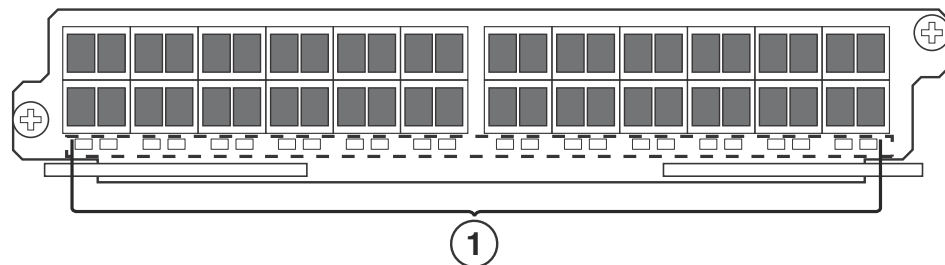

1 Port status LEDs

The front panel includes the following control features:

- LEDs
- 24 1-Gigabit Ethernet mini-GBIC (SFP) ports

**TABLE 5** Gigabit Ethernet module LEDs

Position	State	Meaning
Below each Ethernet port (left-side LED supports port in top row while right-side LED supports port in bottom row)	On or blinking	The port is transmitting and receiving packets.
	Off for an extended period	The port is not transmitting or receiving packets.

---

## Gigabit Ethernet interface module (RJ-45)

Figure 9 shows the 24-port 1 Gigabit Ethernet module's front panel.

FIGURE 9 24-port 1 Gigabit Ethernet module front panel

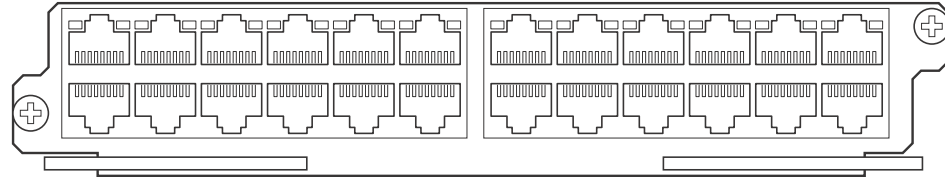

The front panel includes the following control features:

- LEDs
- 24 1-Gigabit Ethernet ports

TABLE 6 Gigabit Ethernet module LEDs

LED	Position	State	Meaning
Link	Left of each Ethernet port	On	A link is established with the remote port.
		Off	A link is not established with the remote port.
Active	Left of each Ethernet port	On or blinking	The port is transmitting and receiving packets.
		Off for an extended period	The port is not transmitting or receiving packets.

## 48-port 1 Gigabit Ethernet interface module (Mini RJ 21 Copper)

The interface modules are hot swappable, which means you can remove and replace them without powering down the system.

Figure 10 shows the 48-port GoC interface module's front panel.

FIGURE 10 48-port GoC interface module front panel

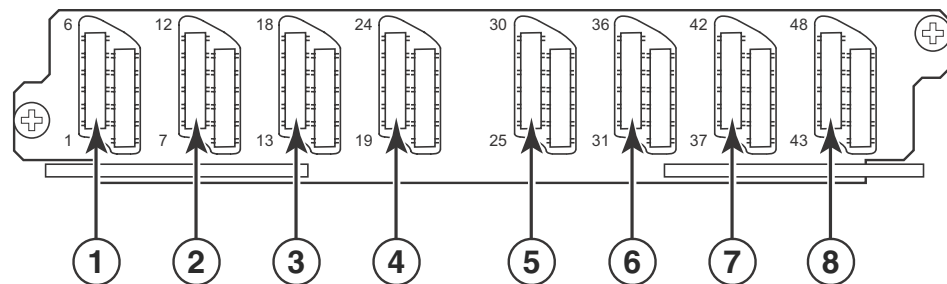

- |   |              |   |             |
|---|--------------|---|-------------|
| 1 | Ports 1 -6   | 5 | Ports 25-30 |
| 2 | Ports 7-12   | 6 | Ports 31-36 |
| 3 | Ports 13 -18 | 7 | Ports 37-42 |
| 4 | Ports 19 -24 | 8 | Ports 43-48 |

# 1 Hardware features

The front panel includes eight Mini RJ-21 Connectors that support six 10/100/1000 Gigabit Ethernet ports each. [Figure 10](#) shows the ports that are supported per RJ-21 connector. A cable connects from the RJ-21 connector on the interface module to a Mini RJ-21 connector on a patch panel. At the patch panel, the ports are broken out into individual RJ-45 connectors for each port.

Cables and patch panels that support this module are available through any Tyco International distribution partner. Information about these products is available at the following URL:

[www.ampnetconnect.com/foundrynetworks](http://www.ampnetconnect.com/foundrynetworks)

## Switch fabric module

The switch fabric module switches uses packets from one interface module installed in a chassis to another. The BigIron RX Series switches can be configured with switch fabric modules as described:

- **BigIron RX-4:** Accommodates three switch fabric elements with two required and one redundant for a fully loaded system. It is shipped with two switch fabric elements. You must purchase an additional switch fabric element if you want your BigIron RX-4 equipped for redundancy.
- **BigIron RX-8:** Accommodates three switch fabric elements with two required and one redundant for a fully loaded system. It is shipped with two switch fabric elements. You must purchase an additional switch fabric element if you want your BigIron RX-8 equipped for redundancy.
- **BigIron RX-16:** Accommodates four switch fabric elements with three required and one redundant for a fully loaded system. It is shipped with three switch fabric elements. You must purchase an additional switch fabric element if you want your BigIron RX-16 equipped for redundancy.
- **BigIron RX-32:** Accommodates and is shipped with eight switch fabric elements. Use with fewer than the minimum number could result in performance degradation.

---

### NOTE

The switch fabric elements used for the BigIron RX-4 are a different part than those used on the BigIron RX-8, BigIron RX-16, and BigIron RX-32.

Also, the switch fabric elements used for the BigIron RX-32 are different than those used on the BigIron RX-4, BigIron RX-8, and BigIron RX-16.

---

### NOTE

The BigIron RX Series switch fabric module is dedicated, which means that it functions properly in the BigIron RX Series chassis only. If you attempt to install a BigIron RX Series switch fabric module in another Brocade chassis or a switch fabric module intended for another Brocade chassis in the BigIron RX Series chassis, the chassis and switch fabric module will not function properly.

---

[Figure 11](#) shows the switch fabric module's front panel.



**FIGURE 11** Switch fabric module front panel

The front panel includes two LEDs, which [Table 7](#) describes.

**TABLE 7** Switch fabric module LEDs

LED	Position	State	Meaning
Pwr	Above Active LED	On	The module is receiving power.
		Off	The module is not receiving power.
Active	Below Pwr LED	On	The chassis switch fabric is active and ready to switch user packets.
		Off for an extended period	The chassis switch fabric is not active and cannot switch user packets.

## Power supplies

The BigIron RX Series switches support the following power supply options:

- **BigIron RX-4:** Accommodates three power supplies (AC or DC) with one required and two redundant. It is shipped with one power supply. You must purchase one or two additional power supplies if you want your BigIron RX-4 equipped for redundancy.
- **BigIron RX-8:** Accommodates four power supplies (AC or DC) with two required and two redundant. Because power is supplied over a common power bus, any power supply purchased in addition to the two required will provide backup for any supply that fails. Equipping a BigIron RX-8 with two additional power supplies provides full redundancy for both of the required power supplies.
- **BigIron RX-16:** Accommodates eight power supplies (AC or DC) with four required and four redundant. Because power is supplied over a common power bus, any power supply purchased in addition to the four required will provide backup for any supply that fails. Equipping a BigIron RX-16 with four additional power supplies provides full redundancy for all of the required power supplies.
- **BigIron RX-32:** Accommodates eight power supplies (AC only at this time) with five required and three redundant. Because power is supplied over a common power bus, any power supply purchased in addition to the five required will provide backup for any supply that fails.

In the BigIron RX-8, BigIron RX-16 and BigIron RX-32, you install the power supplies (AC or DC) in the slots along the bottom of the chassis. In the BigIron RX-4, the power supplies (AC or DC) are installed in slots in the rear of the chassis. The installed power supplies provide power to all chassis components, sharing the workload equally and reporting their status to the management module. If the management module detects that one of these power supplies has failed or overheated, the management module will redistribute the failed power supply's workload to the remaining power supplies.

# 1 Hardware features

Each power supply has three LEDs on its faceplate that provide status for the input power, output power and notification of alarms sent. If the input power and output power LEDs are on (a steady green), the power supply is providing power to the chassis components. The power supplies are hot swappable, which means you can remove and replace them without powering down the system.



## **DANGER**

*The power supplies are hot swappable, which means they can be removed and replaced while the BigIron RX Series chassis is powered on and running. However, Brocade recommends that you disconnect a power supply from its power source before removing and replacing it. The BigIron RX-4, -8, or -16 chassis can be running while a power supply is being removed and replaced, but the power supply itself should not be connected to a power source. Otherwise, you could be injured or the power supply or other parts of the device could be damaged. (In the BigIron RX-32 chassis, you cannot unlatch and remove a power supply without first releasing the cord retainer and removing the power cord.)*

## Cooling system

The cooling system of BigIron RX Series switches is configured as described:

- BigIron RX-4: Is equipped with a fan module containing two 4-speed fans.
- BigIron RX-8: Is equipped with a fan module containing four 4-speed fans.
- BigIron RX-16: Is equipped with three fan assemblies. The fan tray located in the lower front of the chassis contains six 4-speed fans. There are two fan assemblies located in the rear of the chassis. Each of these contain a 4-speed fan that pulls air through the chassis. The BigIron RX-16 is equipped with eight controllers to support redundancy.
- BigIron RX-32: Is equipped with ten fan assemblies in the rear of the chassis. Each of these contain a 4-speed fan that pulls air through the chassis. The bottom fan tray has two fans each for cooling the power supplies.

As shown in [Figure 12](#) and [Figure 13](#), the fans are located in the front of the BigIron RX-4 and BigIron RX-8 chassis. [Figure 14](#) and [Figure 15](#) show the front and rear locations of the fans on the BigIron RX-16. [Figure 16](#) shows the locations of all 10 fans at the rear of the BigIron RX-32 chassis.

---

### **NOTE**

A new revision of the controller for the fan tray assemblies has been added for software release 02.2.01 and later. There is no visible change to the fan assemblies or the procedures for replacing the assemblies. Earlier software versions will not recognize the new controller.

---

**FIGURE 12** Fan component locations for the BigIron RX-4

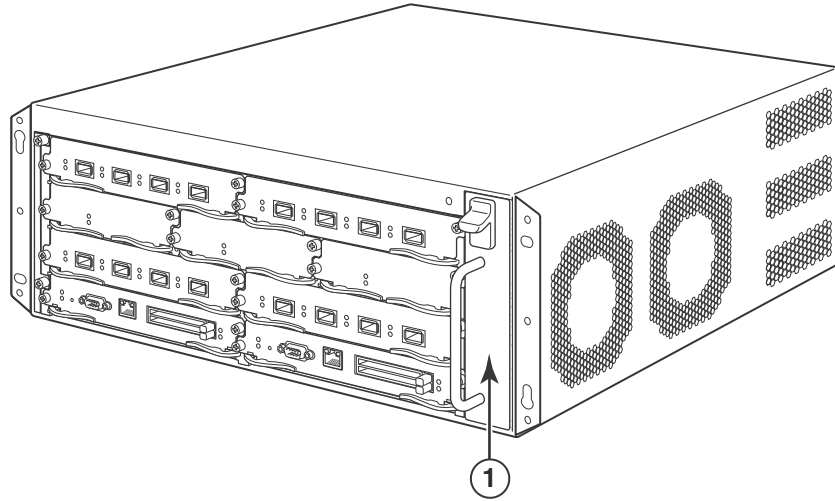

- 1 Fan module

**FIGURE 13** Fan component locations for the BigIron RX-8

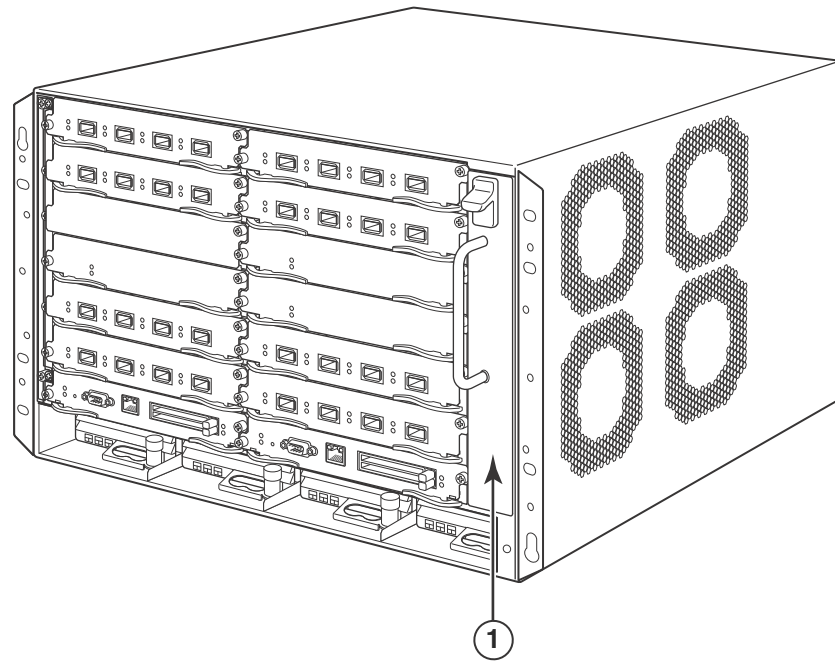

- 1 Fan module

# 1 Hardware features

**FIGURE 14** Front fan component locations for the BigIron RX-16

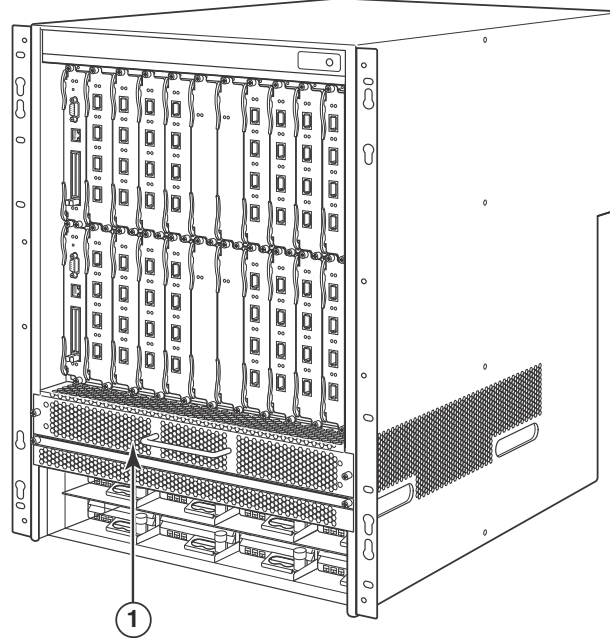

- 1 Front fan assembly

**FIGURE 15** Rear fan component locations for the BigIron RX-16

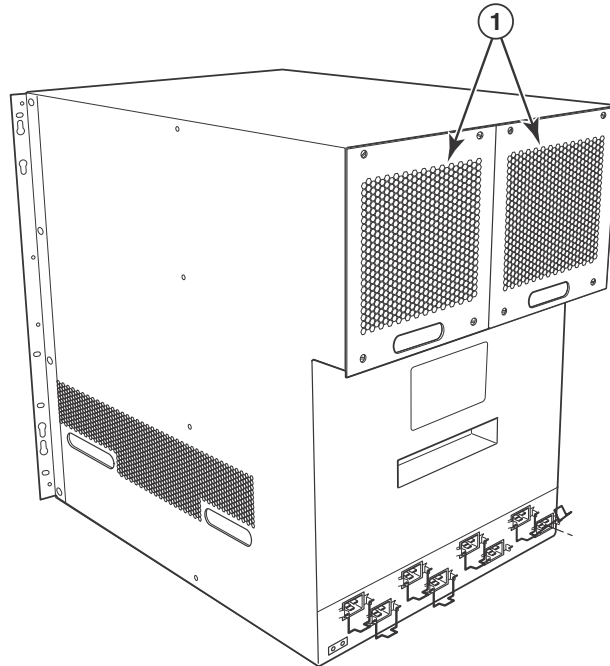

- 1 Fan modules

FIGURE 16 Rear fan component locations for the BigIron RX-32

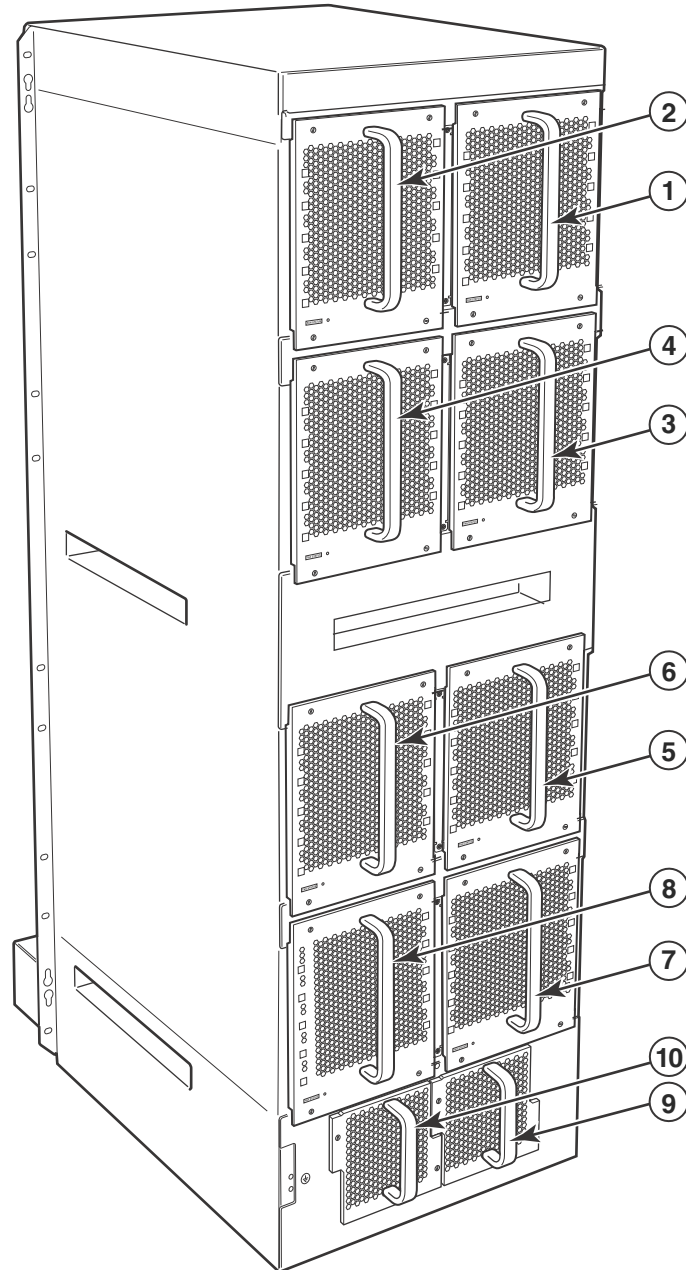

- |   |              |    |               |
|---|--------------|----|---------------|
| 1 | Fan module 1 | 6  | Fan module 6  |
| 2 | Fan module 2 | 7  | Fan module 7  |
| 3 | Fan module 3 | 8  | Fan module 8  |
| 4 | Fan module 4 | 9  | Fan module 9  |
| 5 | Fan module 5 | 10 | Fan module 10 |

Upon system startup, the fans in the BigIron RX Series switches operate at high speed, then the management module lowers the fan speed to low speed.

# 1 Hardware features

By default, the BigIron RX Series switch polls the temperature sensor on each module every 60 seconds to get a temperature reading. Depending on the temperature readings for the modules, the system can do the following:

- Leave the fan speed as is
- Increase the fan speed
- Decrease the fan speed
- Shut down a module to prevent damage

If the temperature of a module exceeds specified high temperature thresholds, the system generates a Syslog message and SNMP trap. The system can also shut the module down if the temperature exceeds the highest threshold.

## LEDs

The BigIron RX-32 fan control modules include a bi-color LED, which indicates the status of the fans. [Table 8](#) describes the LED.

**TABLE 8 Fan control module LED**

LED	Position	State	Meaning
Fan control module LED	Rear of chassis	Off	The fans are not receiving power.
		Green	The fans are working and responding to controls from the fan control module.
		Amber	The fans are not working and not responding to controls from the fan control module.



### CAUTION

**To avoid overheating of the BigIron RX Series chassis, do not remove more than one fan at a time.**

## Rack mount kit

The BigIron RX Series switches are shipped equipped for mounting in a standard 19-inch (EIA310-D) rack as described:

- The BigIron RX-4 and BigIron RX-8 are equipped with built-in mounting brackets and are shipped with mounting screws.
- The BigIron RX-16 and BigIron RX-32 switches ship with two L-shaped mounting brackets and mounting screws.

Alternatively, you can use a mid-mount kit (ordered separately) to center-mount the BigIron RX chassis using two L-shaped mounting brackets. The mid-mount kit comes with instructions for installing the mounting brackets and mounting the device in a rack.

Contact Brocade for information about mid-mount kits.

In a rack, you can install the following number of BigIron RX Series chassis depending on the model:

- BigIron RX-32 – 1 BigIron RX-32 chassis

- BigIron RX-16 – up to 3 BigIron RX-16 chassis
- BigIron RX-8 – up to 6 BigIron RX-8 chassis
- BigIron RX-4 – up to 10 BigIron RX-4 chassis

## Supported software features

For a complete list of software features supported on the BigIron RX Series switch, refer to the software release notes for this device. For information about configuring basic, non-protocol software features supported on this device, refer to the *BigIron RX Series Configuration Guide*.

# 1 Supported software features



# Installing a BigIron RX Series Switch

---

## In this chapter

- Installation precautions ..... 25
- Installing a BigIron RX-4 switch ..... 28
- Installing a BigIron RX-8 switch ..... 38
- Installing a BigIron RX-16 switch ..... 47
- Installing a BigIron RX-32 switch ..... 57
- Attaching a management station ..... 77
- Powering-on the power source ..... 79
- Verifying proper operation ..... 80

## Installation precautions

This chapter contains information on how to install a BigIron RX Series switch. Before proceeding, please read the cautions and danger notices below that apply to the entire family of BigIron RX Series switches.



### **DANGER**

*The procedures in this manual are for qualified service personnel.*



### **DANGER**

*If the installation requires a different power cord than the one supplied with the device, make sure you use a power cord displaying the mark of the safety agency that defines the regulations for power cords in your country. The mark is your assurance that the power cord can be used safely with the device.*

Follow these precautions when installing a BigIron RX Series switch.

## General precautions



### DANGER

*All fiber-optic interfaces use Class 1 Lasers.*



### CAUTION

Do not install the device in an environment where the operating ambient temperature might exceed 40°C (104°F).



### CAUTION

Make sure the air flow around the front, sides, and back of the device is not restricted.



### CAUTION

If you do not install a module in a slot, you must keep the slot blank in place. If you run the chassis with an uncovered slot, the system may overheat.



### CAUTION

Never leave tools inside the chassis.

## Power precautions



### CAUTION

Use a separate branch circuit for each AC power cord, which provides redundancy in case one of the circuits fails.



### DANGER

*Make sure to choose the appropriate circuit device, depending on the number of AC power supplies installed in the chassis.*



### DANGER

*Disconnect the power cord from all power sources to completely remove power from the device.*

**DANGER**

*Make sure that the power source circuits are properly grounded, then use the power cord supplied with the device to connect it to the power source.*

**DANGER**

*If the installation requires a different power cord than the one supplied with the device, make sure you use a power cord displaying the mark of the safety agency that defines the regulations for power cords in your country. The mark is your assurance that the power cord can be used safely with the device.*

**DANGER**

*Make sure the rack or cabinet housing the device is adequately secured to prevent it from becoming unstable or falling over.*

**DANGER**

*Mount the devices you install in a rack or cabinet as low as possible. Place the heaviest device at the bottom and progressively place lighter devices above.*

**CAUTION**

Ensure that the device does not overload the power circuits, wiring, and over-current protection. To determine the possibility of overloading the supply circuits, add the ampere (amp) ratings of all devices installed on the same circuit as the device. Compare this total with the rating limit for the circuit. The maximum ampere ratings are usually printed on the devices near the input power connectors.

**CAUTION**

BigIron RX-4, -8, and -16 devices with DC power sources are intended for installation in restricted access areas only. A restricted access area is where access can be gained only by service personnel through the use of a special tool, lock and key, or other means of security, and is controlled by the authority responsible for the location.

**CAUTION**

All devices with AC power sources (BigIron RX-32 only) are intended for installation in restricted access areas only. A restricted access area is a location where access can be gained only by service personnel through the use of a special tool, lock and key, or other means of security.

## 2 Installing a BigIron RX-4 switch



### CAUTION

For a DC system, the gauge of wire will be determined by the power source as well as the power supply draw (refer to [Table 9](#)). Use a grounding wire of at least 6 American Wire Gauge (AWG). The AWG wire should be attached to an agency-approved crimp connector (provided on the BigIron RX Series chassis), crimped with the proper tool. The single crimp connector should allow for securement to both ground screws on the enclosure. For BigIron RX-16, -8, and -4, use a grounding wire of at least 6 AWG. For the grounding lug, use UL-listed Panduit crimp connector, P/N LCD6-10A, and two 10-32, PPH screws to secure the crimp connector to chassis. The grounding position is located on the side of chassis adjacent ground symbol.

TABLE 9 The American Wire Gauge (AWG) guidelines

AWG	Ohms per 100 feet	Maximum Amps for chassis wiring	Maximum Amps for power transmission
5	0.3133	118	47
6	0.3951	101	37
7	0.4982	89	30
8	0.6282	73	24
9	0.7921	64	19
10	0.9989	55	15
11	1.26	47	12
12	1.588	41	9.3



### CAUTION

For the DC input circuit to the system, make sure there is a UL-Listed 30 amp circuit breaker, minimum -48Vdc, double pole, on the input to the terminal block. The input wiring for connection to the product should be Listed copper wire, 8 AWG, marked VW-1, and rated minimum 90 C.



### CAUTION

For a BigIron RX-32 AC system, use a ground wire of at least 6 American Wire Gauge (AWG). The ground wire should have an agency-approved crimped connector (provided with the chassis) attached to one end, with the other end attached to building ground. The connector must be crimped with the proper tool, allowing it to be connected to both ground screws on the enclosure.

## Installing a BigIron RX-4 switch

This section describes the steps you will perform to install a BigIron RX-4 switch:

- [“Preparing the installation site”](#)
- [“Unpacking a BigIron RX-4 switch”](#)
- [“Chassis lifting guidelines for BigIron RX-4 switches”](#)

- [“Installing a BigIron RX-4 chassis in a rack”](#)
- [“Installing BigIron RX-4 modules”](#)
- [“Installing power supplies in a BigIron RX-4 chassis”](#)
- [“Connecting AC power to a BigIron RX-4 chassis”](#)
- [“Connecting DC power to a BigIron RX-4 chassis”](#)
- [“Final steps”](#)

## Preparing the installation site

### *Cabling infrastructure*

Ensure that the proper cabling is installed in the site.

For information on cabling, refer to [“Installing power supplies in a BigIron RX-4 chassis”](#) on page 35, [“Attaching a management station”](#) on page 77, and [“Connecting a BigIron RX Series switch”](#) on page 105.

### *Installation location*

Before installing the switch, plan its location and orientation relative to other devices and equipment. For cooling purposes, allow a minimum of six inches of space between the sides, front, and the back of the chassis and walls or other obstructions. If a chassis is installed within a perforated enclosure, the perforations must have openings of at least 60 percent of the surface.

## Unpacking a BigIron RX-4 switch

The BigIron RX-4 switch ships with several items. Review the list below, and verify the contents. If any items are missing, contact the place of purchase:

- BigIron RX-4 chassis with the appropriate number of switch fabric modules already installed in the slot marked SF and a slot blank installed in all other module slots.

---

### **NOTE**

You must provide standard #12-24 pan-head screws for mounting the BigIron RX-4 chassis into a rack.

---

- CD-ROM containing software images and the user documentation (including this guide).
- Warranty card.
- A 115V AC power cable for each AC power supply you purchase from Brocade.

Follow the steps given below to unpack a BigIron RX-4 chassis.

1. Move the pallet to a staging area as close to the installation site as possible.
2. Position the shipping carton with the arrows pointing up.
3. Remove the strap that secures the shipping carton to the pallet.
4. Remove the plastic cover and shipping carton.
5. Save the shipping carton, pallet, and packing materials in case you need to move or ship the chassis at a later time.

## Chassis lifting guidelines for BigIron RX-4 switches



### **DANGER**

***A fully-populated BigIron RX-4, chassis is heavy. TWO OR MORE PEOPLE ARE REQUIRED WHEN LIFTING, HANDLING, OR MOUNTING THESE DEVICES.***

Follow these guidelines for lifting and moving a BigIron RX-4 chassis:

- Before lifting or moving the switch, disconnect all external cables.

## Installing a BigIron RX-4 chassis in a rack

This section describes the following tasks:

- [“Preparing to mount a BigIron RX-4 chassis in a rack”](#)
- [“Removing BigIron RX-4 extra shipment screws”](#)
- [“Mounting a BigIron RX-4 chassis in a rack”](#)
- [“Removing the slot blanks”](#)

### ***Preparing to mount a BigIron RX-4 chassis in a rack***

Because of the weight of a fully loaded BigIron RX-4 chassis, Brocade recommends mounting a chassis in a rack before installing the modules and AC power supplies if necessary.

In a standard 19-inch (EIA310-D) rack, you can install up to ten BigIron RX-4 chassis.

For each BigIron RX-4 chassis that you install in a rack, you must provide four standard #12-24 pan-head screws with which to mount and secure the chassis. Before performing this task, you should have an assembled rack and a #2 Phillips-head screwdriver.

### ***Removing BigIron RX-4 extra shipment screws***

The BigIron RX-4 ships with two extra screws installed in the right side of the chassis. These screws secure the fan tray, protecting it from damage during shipment. You must remove these screws before installing the chassis. [Figure 17](#) shows the location of the screws.

To perform this task, you need a #2 Phillips-head screwdriver.

**FIGURE 17** Removing the extra screws used for shipment

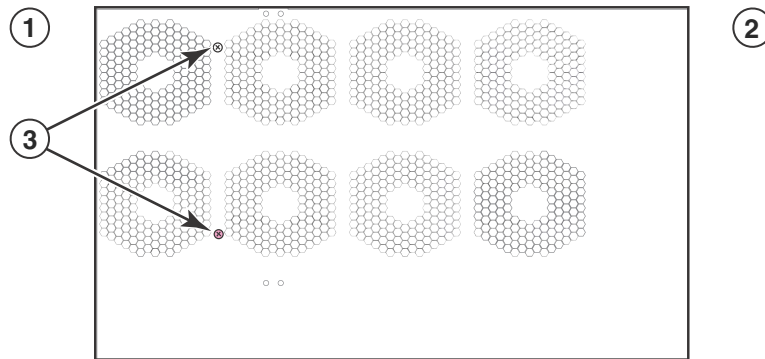

- |   |                 |   |              |
|---|-----------------|---|--------------|
| 1 | Chassis front   | 3 | Chassis rear |
| 2 | Shipping screws |   |              |

### ***Mounting a BigIron RX-4 chassis in a rack***

Follow the steps given below to mount a BigIron RX-4 chassis in a rack.

1. Determine the position of each chassis in the rack, for example, a chassis with the fewest modules on top, a chassis with more modules than the top chassis in the middle, and a fully populated chassis on the bottom.
2. Position two of the four screws for each chassis according to the spacings of the keyhole slots on the mounting brackets as shown in [Figure 18](#). Do not secure the screws completely; leave approximately 1/4 inch of clearance between the back of the screw head and the rack.

**FIGURE 18** Positioning the screws in a rack

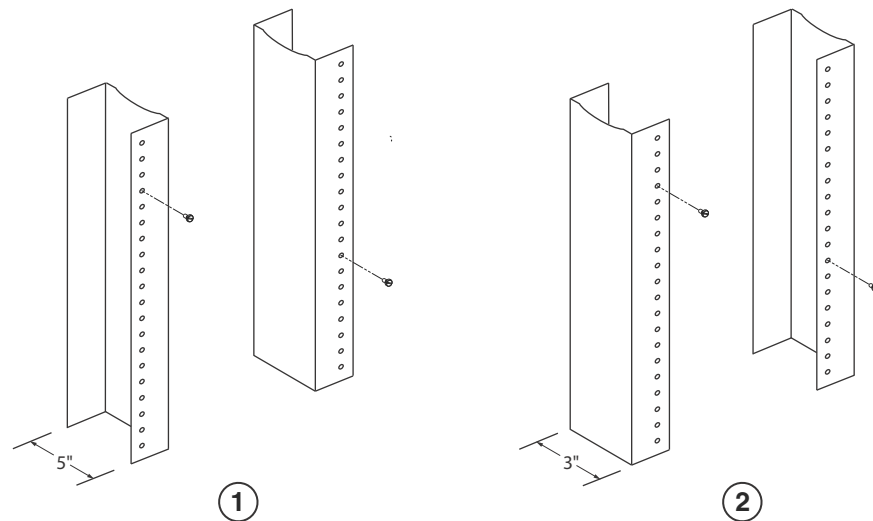

- |   |                               |   |                        |
|---|-------------------------------|---|------------------------|
| 1 | Unequal flange equipment rack | 2 | Network equipment rack |
|---|-------------------------------|---|------------------------|

## 2 Installing a BigIron RX-4 switch

3. Starting with the chassis that you want to mount in the lowest position in the rack, mount the chassis in the rack as shown in [Figure 19](#). With two or more people lifting the chassis, slip the wide portion of each keyhole slot over the corresponding screw in the rack.

**FIGURE 19** Mounting the BigIron RX-4 or BigIron RX-8 chassis in a rack

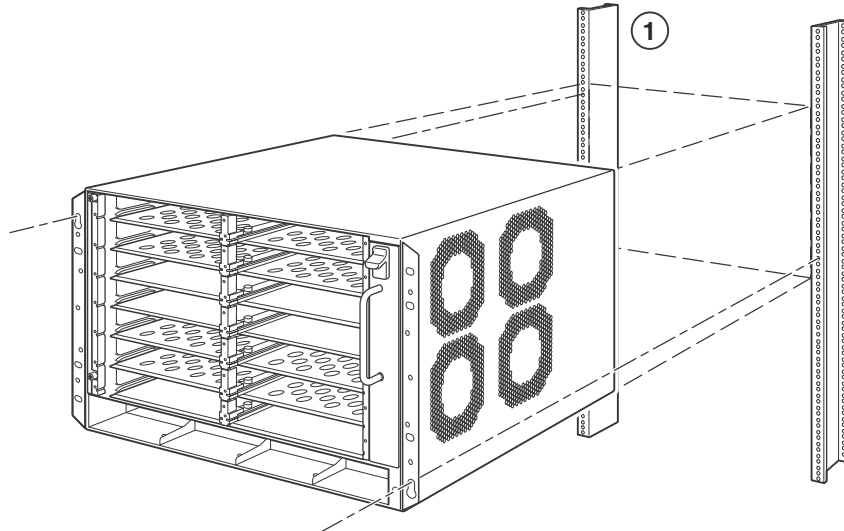

1. Standard 19 inch rack
4. Slide the chassis down so that the screw heads are in the narrow portion of the keyhole slots.
5. Tighten the screws to secure the chassis in place.

---

### NOTE

To provide better grounding of the chassis to the rack, attach the chassis to the rack using star washers. Additionally, if any single hole grounding lugs are used star washers shall be used as a means to prevent rotation of the lug.

---

6. Add additional screws as required.
7. Repeat [step 2](#) through [step 6](#) to mount each subsequent chassis in the same rack.

### *Removing the slot blanks*

The BigIron RX-4 chassis ships with slot blanks installed in all module slots. The slot blank covers a slot that does not currently have a module installed in it, ensuring proper airflow within the chassis. If you plan to install a module in a particular slot, you must remove the slot blank.



### CAUTION

**If you do not install a module in a slot, you must keep the slot blank in place. If you run the chassis with an uncovered slot, the system may overheat. Tighten the screws that secure the slot blanks so that they remain in place when removing adjacent panels or modules.**

---



Although the slot blanks are different in size, the procedure for removing them from the BigIron RX-4 chassis is the same. Therefore, this section provides one procedure that applies to all slot blanks.

You will need a flat-head screwdriver to perform this task.

Follow the steps given below to remove a slot blank.

1. Loosen the screws on either end of the slot blank by hand or with a flat-head screwdriver.
2. Pull the slot blank out of the chassis, and store it in a safe place for future use.

## Installing BigIron RX-4 modules

This section provides one procedure that applies to all modules. The sequence for installing more than one module is important to ensure proper fit. The recommended sequence for the BigIron RX-4 chassis is to start with the lowest row, moving upwards, from right-to-left.

---

### NOTE

The BigIron RX Series modules are dedicated, which means that you must install them in the BigIron RX Series chassis only. For example, if you attempt to install the BigIron RX Series management module in another Brocade chassis or a management module intended for another Brocade chassis in the BigIron RX Series chassis, the chassis and module will not function properly.

---

[Table 10](#) provides the chassis slot numbers into which you must install the modules. Markings for the chassis slots appear at the base of the slots.

The BigIron RX-4 chassis ships with the required switch fabric modules installed.

**TABLE 10** BigIron RX-4 module installation

BigIron RX-4 module	Chassis slot number
Management modules	Active module – M1 (left). Redundant module – M2 (right).
Interface modules	1 – 4
Switch fabric modules	SF1 – SF3



### CAUTION

**If you do not install a module in a slot, you must leave the slot blank installed in the slot. If you run the BigIron RX-4 chassis with an uncovered slot, the system may overheat.**

If you are installing a redundant management module, refer to the *Using a Redundant Management Module* chapter in the *BigIron RX Configuration Guide* for information about how the redundant module works, optional software configurations that you can perform, and how to manage the redundancy feature.

Before installing a module in the BigIron RX-4 chassis, have the following on hand:

## 2 Installing a BigIron RX-4 switch

- An ESD wrist strap with a plug for connection to the ESD connector on the BigIron RX-4 chassis.



### **DANGER**

***For safety reasons, the ESD wrist strap should contain a 1 meg ohm series resistor.***

- A large flat-head screwdriver.

Follow the steps given below to install a module in the BigIron RX-4 chassis.

1. Put on the ESD wrist strap and ground yourself by inserting the plug into the ESD connector on the chassis front.
2. Remove the module from its packaging.
3. With the ejectors in the outward position, insert the module into the appropriate chassis slot and slide the card along the card guide until the ejectors on either side of the module move close to the module front panel.

**FIGURE 20** Installing a module in a BigIron RX-4 chassis

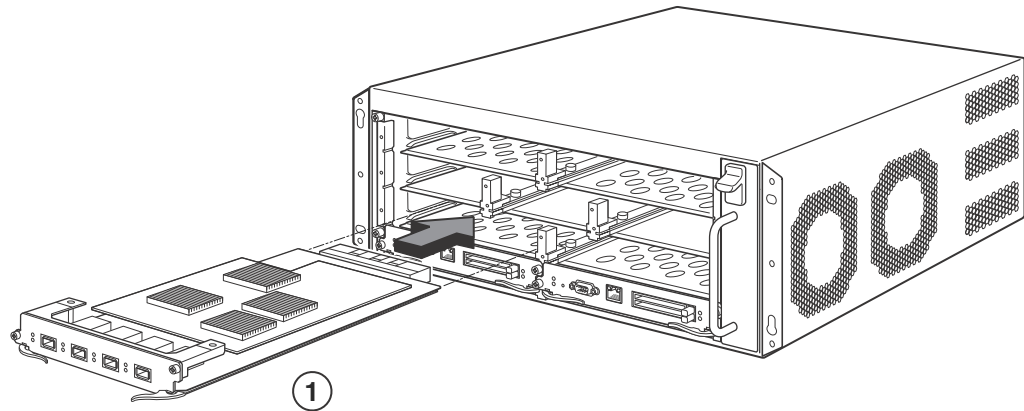

- 1 Interface module

---

### **NOTE**

When inserting the module into the chassis, make sure that the faceplate does not overlap with the faceplate of an adjacent interface module.

---

4. Push the ejectors in until they are flush with the module front panel. This action will fully seat the module in the backplane. Modules have a snug fit for maximum EMI protection.

---

### **NOTE**

The installation instructions for installing modules shown in the following illustrations are exactly the same for interface, management, and switch fabric modules.

---

5. Tighten the two screws at either end of the module front panel by pushing them in and turning them clockwise. Then, tighten the screws further using the flat-head screwdriver.

## Installing power supplies in a BigIron RX-4 chassis

The BigIron RX-4 accommodates three power supplies (AC or DC) with one required and two redundant. It is shipped with one power supply. You must purchase one or two additional power supplies if you want your BigIron RX-4 equipped for redundancy. You need a small Phillips or flat-head screwdriver to perform this task.

Follow the steps given below to install a power supply in the BigIron RX-4 chassis.

1. Remove the blank power supply faceplate, and expose the empty power supply slot.
2. Remove the power supply from its packaging.
3. Insert the power supply into the empty power supply slot, using the guides provided on either side of the slot and slide the card along the card guide until the ejectors on either side of the module move close to the module front panel.

---

### NOTE

Empty power supply slots should be covered with slot blanks.

---



### CAUTION

Carefully follow the mechanical guides on each side of the power supply slot and make sure the power supply is properly inserted in the guides. Never insert the power supply upside down.

FIGURE 21 Installing a power supply in a BigIron RX-4 chassis

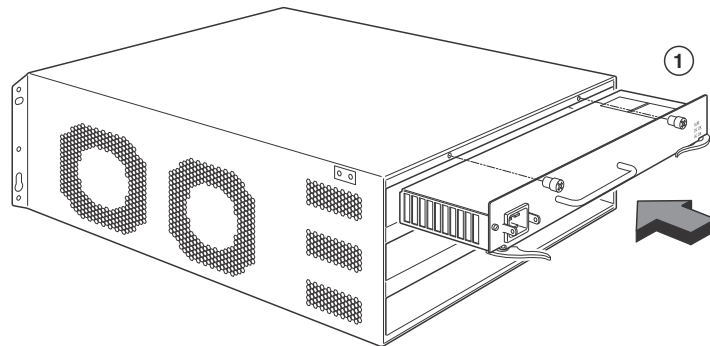

1. Power supply
4. After the power supply is fully inserted, push the power supply front panel toward the back of the chassis. This action causes the power supply connector to seat into the backplane connector.
5. Push the ejectors in until they are flush with the face of the power supply. This action will fully latch the power supply in the backplane.
6. Tighten the two screws at either end of the power supply front panel by pushing them in and turning them clockwise. If desired, tighten the screws further using the flat-head screwdriver.
7. For information about connecting power to the chassis, refer to [“Connecting AC power to a BigIron RX-4 chassis”](#) on page 36 or [“Connecting DC power to a BigIron RX-4 chassis”](#) on page 36.

## Connecting AC power to a BigIron RX-4 chassis

AC power is supplied through an AC power cord that is installed at the rear of the BigIron RX-4 chassis.

1. At the rear of the BigIron RX-4 chassis locate the power receptacle on the left side of the AC power supply.
2. Lift the cord-retainer and connect a Brocade-supplied AC power cord to the power supply.
3. Snap the cord-retainer over the power plug to hold it in place.

FIGURE 22 Connecting a power cord to the power supply in a BigIron RX-4 chassis

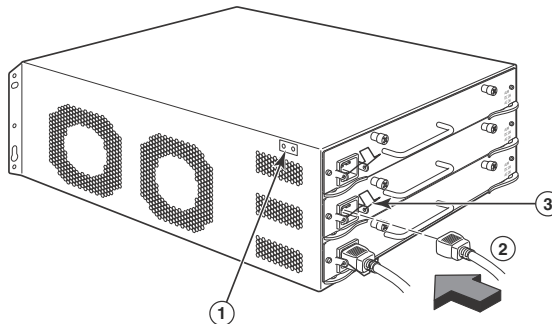

- |   |              |   |               |
|---|--------------|---|---------------|
| 1 | Ground point | 3 | Cord retainer |
| 2 | Power cord   |   |               |



### **DANGER**

*If the installation requires a different power cord than the one supplied with the device, make sure you use a power cord displaying the mark of the safety agency that defines the regulations for power cords in your country. The mark is your assurance that the power cord can be used safely with the device.*

4. For information about powering on the system, refer to [“Powering-on the power source”](#) on page 79.

## Connecting DC power to a BigIron RX-4 chassis

You can provide your own DC power source for the BigIron RX-4 chassis. This is supported through use of a DC-to-DC power supply. DC power must be supplied at 48 V and 30 A. The DC-to-DC supply provides the DC power to the chassis at 12 V and 100 A.



### **DANGER**

*The procedure in this section is for qualified service personnel.*

Follow the steps given below to connect a DC power source.

#### NOTE

The layout of the LEDs on your BigIron RX-4 DC power supply may be different from what is shown in [Figure 23](#), due to multiple vendors; but the function is the same.

1. Use a flat-blade screwdriver to remove the two screws holding the transparent cover over the power supply lugs.

**FIGURE 23** The BigIron RX-4 DC power supply

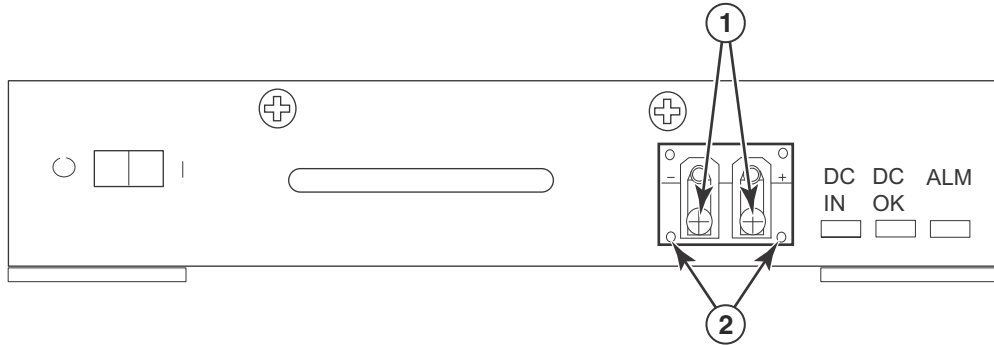

- 1 Screws holding power lugs
  - 2 Screws holding transparent cover
2. Use a Phillips head screwdriver to remove each of the power lugs.
  3. Crimp #8 AWG power supply wire into the power lugs and reconnect the power lugs to the power supply unit.

**FIGURE 24** Crimping the power supply wire in the lug

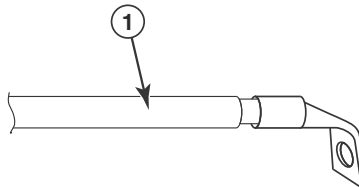

- 1 #8 AWG power supply wire
4. Re-attach the transparent cover over the power supply lugs that was removed in Step 1.
  5. Connect the wire to your DC power source making sure to connect the -48V cable to the negative terminal on the power supply and the 0V cable to the positive terminal.

## Final steps

Follow the steps listed below to complete the installation:

- [“Attaching a management station”](#)
- [“Powering-on the power source”](#)
- [“Verifying proper operation”](#)

## Installing a BigIron RX-8 switch

This section describes the following tasks:

- [“Preparing the installation site”](#)
- [“Unpacking a BigIron RX-8 switch”](#)
- [“Chassis lifting guidelines for BigIron RX-8 switches”](#)
- [“Installing the BigIron RX-8 chassis in a rack”](#)
- [“Installing BigIron RX-8 modules”](#)
- [“Installing power supplies in the BigIron RX-8 chassis”](#)
- [“Connecting AC power to a BigIron RX-8 chassis”](#)
- [“Connecting DC power to a BigIron RX-8 chassis”](#)
- [“Final steps”](#)

### Preparing the installation site

#### *Cabling infrastructure*

Ensure that the proper cabling is installed in the site.

For information on cabling, refer to [“Installing power supplies in the BigIron RX-8 chassis”](#) on page 44, [“Attaching a management station”](#) on page 77, and [“Connecting a BigIron RX Series switch”](#) on page 105.

#### *Installation location*

Before installing the switch, plan its location and orientation relative to other devices and equipment. For cooling purposes, allow a minimum of six inches of space between the sides, front, and the back of the chassis and walls or other obstructions. If a chassis is installed within a perforated enclosure, the perforations must have openings of at least 60 percent of the surface.

### Unpacking a BigIron RX-8 switch

The BigIron RX-8 switch ships with several items. Review the list below, and verify the contents. If any items are missing, contact the place of purchase:

- BigIron RX-8 chassis with the appropriate number of switch fabric modules already installed in the slot marked SF and a slot blank installed in all other module slots.

---

#### **NOTE**

You must provide standard #12-24 pan-head screws for mounting the BigIron RX Series chassis into a rack.

---

- CD-ROM containing software images and the user documentation (including this guide).
- Warranty card.
- A 115V AC power cable for each AC power supply you purchase from Brocade.

Follow the steps given below to unpack a BigIron RX-8 chassis.

1. Move the pallet to a staging area as close to the installation site as possible.
2. Position the shipping carton with the arrows pointing up.
3. Remove the strap that secures the shipping carton to the pallet.
4. Remove the plastic cover and shipping carton.
5. Save the shipping carton, pallet, and packing materials in case you need to move or ship the chassis at a later time.

## Chassis lifting guidelines for BigIron RX-8 switches



### **DANGER**

***A fully-populated BigIron RX-8, chassis is heavy. TWO OR MORE PEOPLE ARE REQUIRED WHEN LIFTING, HANDLING, OR MOUNTING THESE DEVICES.***

Follow these guidelines for lifting and moving a BigIron RX-8 chassis:

- Before lifting or moving the switch, disconnect all external cables.
- Do not attempt to lift a fully configured switch by yourself. Using a mechanical lift to maneuver the switch into a rack is recommended. If a lift cannot be used, a minimum of four people must lift the switch, and you must remove components from the chassis before lifting.

## Installing the BigIron RX-8 chassis in a rack

This section describes the following tasks:

- [“Preparing to mount a BigIron RX-8 chassis in a rack”](#)
- [“Removing BigIron RX-8 extra shipment screws”](#)
- [“Mounting a BigIron RX-8 chassis in a rack”](#)
- [“Removing the slot blanks”](#)

### ***Preparing to mount a BigIron RX-8 chassis in a rack***

Because of the weight of a fully loaded BigIron RX-8 chassis, Brocade recommends mounting a chassis in a rack before installing the modules and AC power supplies if necessary.

In a standard 19-inch (EIA310-D) rack, you can install up to six BigIron RX-8 chassis.

For each BigIron RX-8 chassis that you install in a rack, you must provide four standard #12-24 pan-head screws with which to mount and secure the chassis. Before performing this task, you should have an assembled rack and a #2 Phillips-head screwdriver.

### ***Removing BigIron RX-8 extra shipment screws***

The BigIron RX-8 ships with two extra screws installed in the right side of the chassis. These screws secure the fan tray, protecting it from damage during shipment. You must remove these screws before installing the chassis. [Figure 25](#) shows the location of the screws.

## 2 Installing a BigIron RX-8 switch

To perform this task, you need a #2 Phillips-head screwdriver.

**FIGURE 25** Removing the extra screws used for shipment

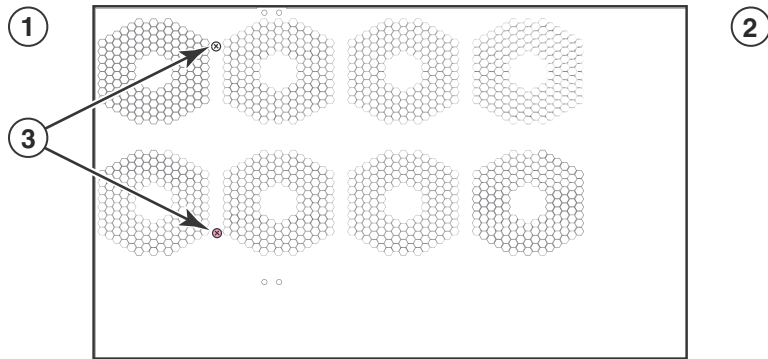

- 1 Chassis front
- 2 Chassis rear
- 3 Shipping screws

### ***Mounting a BigIron RX-8 chassis in a rack***

Follow the steps given below to mount a BigIron RX-8, chassis in a rack.

1. Determine the position of each chassis in the rack, for example, a chassis with the fewest modules on top, a chassis with more modules than the top chassis in the middle, and a fully populated chassis on the bottom.
2. Position two of the four screws for each chassis according to the spacings of the keyhole slots on the mounting brackets as shown in [Figure 26](#). Do not secure the screws completely; leave approximately 1/4 inch of clearance between the back of the screw head and the rack.

**FIGURE 26** Positioning the screws in a rack

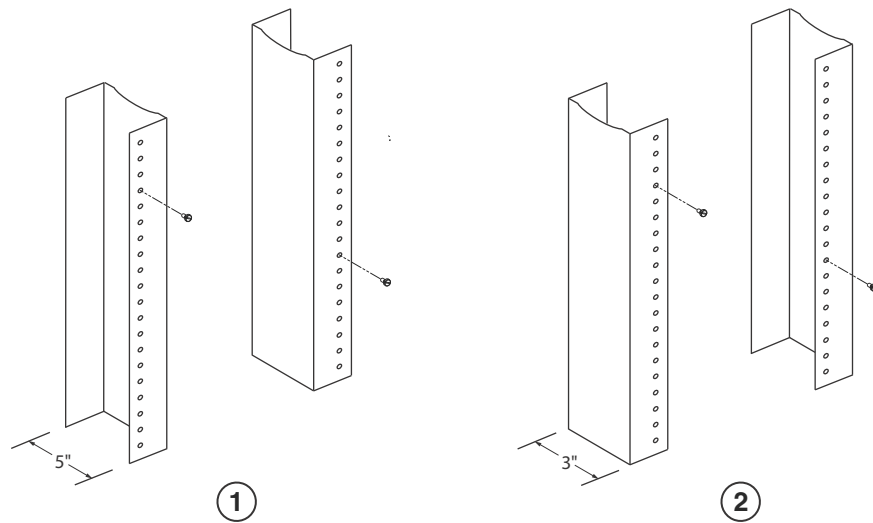

- 1 Unequal flange equipment rack
- 2 Network equipment rack



- Starting with the chassis that you want to mount in the lowest position in the rack, mount the chassis in the rack as shown in [Figure 27](#). With two or more people lifting the chassis, slip the wide portion of each keyhole slot over the corresponding screw in the rack.

**FIGURE 27** Mounting the BigIron RX-4 or BigIron RX-8 chassis in a rack

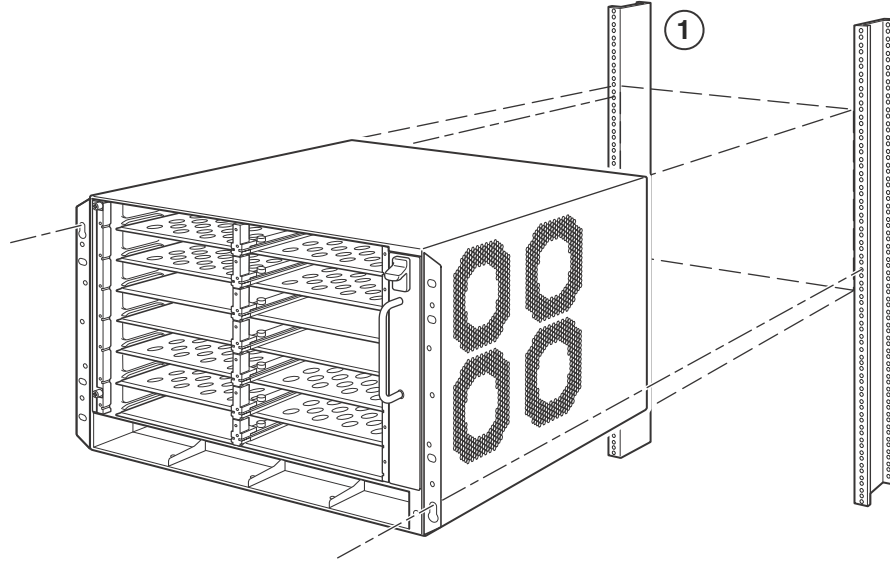

- Standard 19-inch rack
- Slide the chassis down so that the screw heads are in the narrow portion of the keyhole slots.
- Tighten the screws to secure the chassis in place.

---

**NOTE**

To provide better grounding of the chassis to the rack, attach the chassis to the rack using star washers. Additionally, if any single hole grounding lugs are used star washers shall be used as a means to prevent rotation of the lug.

---

- Add additional screws as required.
- Repeat [step 2](#) through [step 6](#) to mount each subsequent chassis in the same rack.

***Removing the slot blanks***

The BigIron RX-8 chassis ships with slot blanks installed in all module slots. The slot blank covers a slot that does not currently have a module installed in it, ensuring proper airflow within the chassis. If you plan to install a module in a particular slot, you must remove the slot blank.



**CAUTION**

**If you do not install a module in a slot, you must keep the slot blank in place. If you run the chassis with an uncovered slot, the system may overheat. Tighten the screws that secure the slot blanks so that they remain in place when removing adjacent panels or modules.**

---

## 2 Installing a BigIron RX-8 switch

Although the slot blanks are different in size, the procedure for removing them from the BigIron RX-8 chassis is the same. Therefore, this section provides one procedure that applies to all slot blanks.

You will need a flat-head screwdriver to perform this task.

Follow the steps given below to remove a slot blank.

1. Loosen the screws on either end of the slot blank by hand or with a flat-head screwdriver.
2. Pull the slot blank out of the chassis, and store it in a safe place for future use.

### Installing BigIron RX-8 modules

This section provides one procedure that applies to all modules. The sequence for installing more than one module is important to ensure proper fit. For the BigIron RX-8 chassis, starting from the lowest row and moving upwards, install the modules right-to-left.

In the BigIron RX-8, install the modules right-to-left.

---

#### NOTE

The BigIron RX Series modules are dedicated, which means that you must install them in the BigIron RX Series chassis only. For example, if you attempt to install the BigIron RX Series management module in another Brocade chassis or a management module intended for another Brocade chassis in the BigIron RX Series chassis, the chassis and module will not function properly.

---

[Table 11](#) provides the chassis slot numbers into which you must install the modules. Markings for the chassis slots appear at the base of the slots.

**TABLE 11** BigIron RX-8 module installation

BigIron RX-8 module	Chassis slot number
Management modules	Active module – M1 (left). Redundant module – M2 (right).
Interface modules	1 – 8
Switch fabric modules	SF1 – SF3

The BigIron RX-8 chassis ships with the required switch fabric modules installed.



#### CAUTION

**If you do not install a module in a slot, you must leave the slot blank installed in the slot. If you run the BigIron RX-8 chassis with an uncovered slot, the system may overheat.**

If you are installing a redundant management module, refer to the *Using a Redundant Management Module* chapter in the *BigIron RX Series Configuration Guide* for information about how the redundant module works, optional software configurations that you can perform, and how to manage the redundancy feature.

Before installing a module in the BigIron RX-8 chassis, have the following on hand:

- An ESD wrist strap with a plug for connection to the ESD connector on the BigIron RX-8 chassis.



### **DANGER**

***For safety reasons, the ESD wrist strap should contain a 1 meg ohm series resistor.***

- A large flat-head screwdriver.

Follow the steps given below to install a module in the BigIron RX-8 chassis.

1. Put on the ESD wrist strap and ground yourself by inserting the plug into the ESD connector on the chassis front.
2. Remove the module from its packaging.
3. With the ejectors in the outward position, insert the module into the appropriate chassis slot and slide the card along the card guide until the ejectors on either side of the module move close to the module front panel.

**FIGURE 28** Installing a module in a BigIron RX-8 chassis

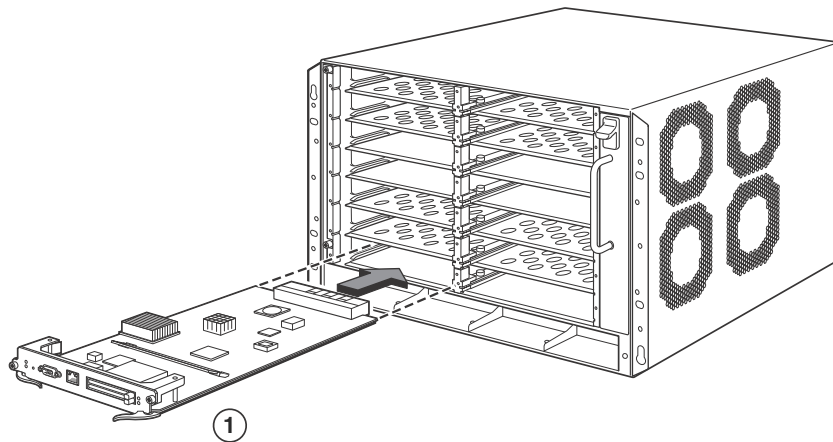

- 1 Management module

---

### **NOTE**

When inserting the module into the chassis, make sure that the faceplate does not overlap with the faceplate of an adjacent interface module.

---

4. Push the ejectors in until they are flush with the module front panel. This action will fully seat the module in the backplane. Modules have a snug fit for maximum EMI protection.
- 

### **NOTE**

The installation instructions for installing modules shown in the following illustrations are exactly the same for interface, management, and switch fabric modules.

---

5. Tighten the two screws at either end of the module front panel by pushing them in and turning them clockwise. Then, tighten the screws further using the flat-head screwdriver.

## Installing power supplies in the BigIron RX-8 chassis

The BigIron RX-8 accommodates three power supplies (AC or DC) with one required and two redundant. It is shipped with one power supply. You must purchase one or two additional power supplies if you want your BigIron RX-8 equipped for redundancy.

Follow the steps given below to install a power supply in the BigIron RX-8 chassis.

1. Remove the blank power supply faceplate, and expose the empty power supply slot.
2. Remove the power supply from its packaging.
3. Insert the power supply into the empty power supply slot, using the guides provided on either side of the slot.



### CAUTION

Carefully follow the mechanical guides on each side of the power supply slot and make sure the power supply is properly inserted in the guides. Never insert the power supply upside down.

FIGURE 29 Installing a power supply in a BigIron RX-8 chassis

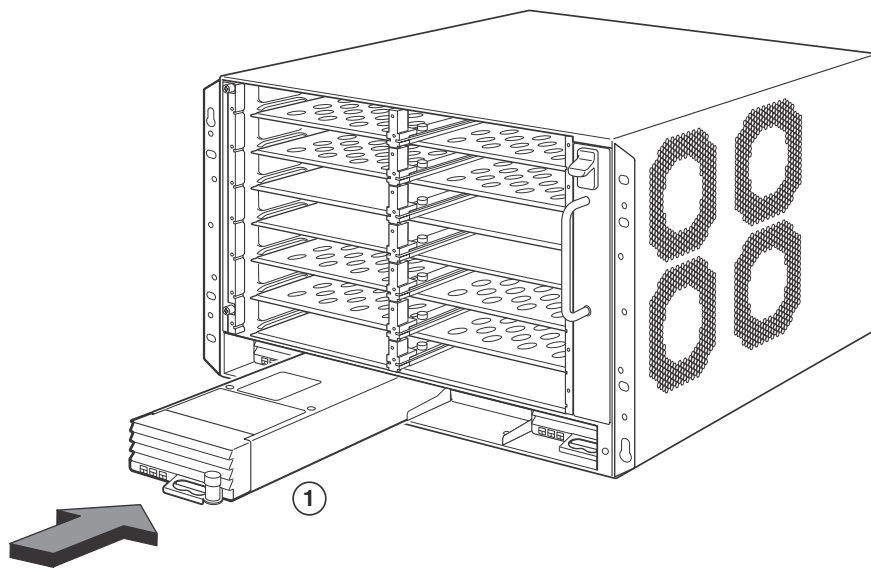

1. Power supply
4. For the BigIron RX-8 chassis, install a blank power supply faceplate into each slot that is empty after all of the power supplies have been installed.
5. After the power supply is fully inserted, push the power supply front panel toward the back of the chassis. This action causes the power supply connector to latch into the backplane connector.
6. For the BigIron RX-8, gently pull the handle on the power supply front panel upward and toward the top of the power supply front panel. This action locks the power supply in place.

7. For information about connecting power to the chassis, refer to [“Connecting AC power to a BigIron RX-8 chassis”](#) on page 45, or [“Connecting DC power to a BigIron RX-8 chassis”](#) on page 46.

## Connecting AC power to a BigIron RX-8 chassis

AC power is supplied through an AC power cord that is installed at the rear of the BigIron RX-8 chassis.

1. At the rear of the BigIron RX-8 chassis, locate the power receptacle where the power supplies have been installed.
2. Lift the cord-retainer and connect a Brocade-supplied AC power cord to the power supply.
3. Snap the cord-retainer over the power plug to hold it in place.

**FIGURE 30** Connecting a power cord to the power supply in a BigIron RX-8 chassis

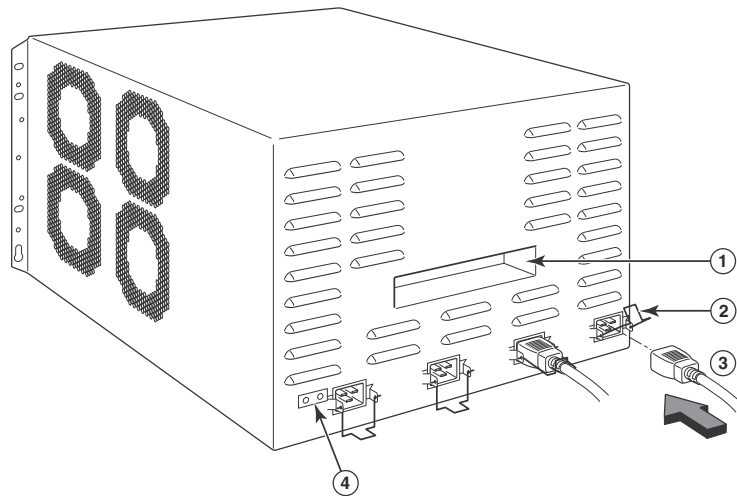

- |   |               |   |              |
|---|---------------|---|--------------|
| 1 | Lift handle   | 3 | Power cord   |
| 2 | Cord retainer | 4 | Ground point |



### **DANGER**

*If the installation requires a different power cord than the one supplied with the device, make sure you use a power cord displaying the mark of the safety agency that defines the regulations for power cords in your country. The mark is your assurance that the power cord can be used safely with the device.*

4. For information about powering on the system, refer to [“Powering-on the power source”](#) on page 79.

## Connecting DC power to a BigIron RX-8 chassis

You can use a DC power source for the BigIron RX-8 chassis. This is supported through use of a DC-to-DC power supply. DC power must be supplied at 48 V and 30 A. The DC-to-DC supply provides the DC power to the chassis at 12 V and 100 A.



### **DANGER**

*The procedure in this section is for qualified service personnel.*

Follow the steps given below to connect a DC power source.

1. Use a flat-blade screwdriver to remove the two screws holding the transparent cover over the power supply lugs.

**FIGURE 31** The BigIron RX-8 and BigIron RX-16 DC power supply

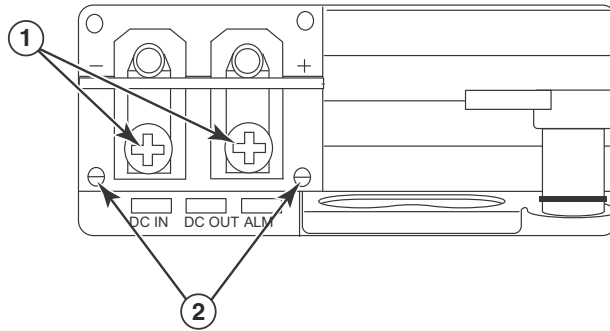

- 1 Screws holding power lugs
  - 2 Screws holding transparent cover
2. Use a Phillips head screwdriver to remove each of the power lugs.
  3. Crimp #8 AWG power supply wire into the power lugs and reconnect the power lugs to the power supply unit.

**FIGURE 32** Crimping the power supply wire in the lug

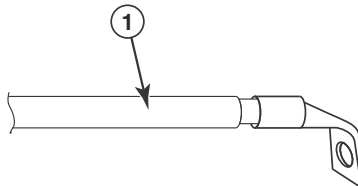

- 1 #8 AWG power supply wire
4. Re-attach the transparent cover over the power supply lugs that was removed in Step 1.
  5. Connect the wire to your DC power source, making sure to connect the -48V cable to the negative terminal on the power supply and the 0V cable to the positive terminal as marked on the power supply.

## Final steps

Follow the steps listed below to complete the installation:

- [“Attaching a management station”](#)
- [“Powering-on the power source”](#)
- [“Verifying proper operation”](#)

## Installing a BigIron RX-16 switch

This section describes the following tasks:

- [“Preparing the installation site”](#)
- [“Unpacking a BigIron RX-16 switch”](#)
- [“Chassis lifting guidelines for BigIron RX-16 switches”](#)
- [“Installing a BigIron RX-16 chassis in a rack”](#)
- [“Installing BigIron RX-16 modules”](#)
- [“Installing power supplies in a BigIron RX-16 chassis”](#)
- [“Connecting AC power to a BigIron RX-16 chassis”](#)
- [“Connecting DC power to a BigIron RX-16 chassis”](#)
- [“Final steps”](#)

## Preparing the installation site

### *Cabling infrastructure*

Ensure that the proper cabling is installed in the site.

For information on cabling, refer to [“Installing power supplies in a BigIron RX-16 chassis”](#) on page 54, [“Attaching a management station”](#) on page 77, and [“Connecting a BigIron RX Series switch”](#) on page 105.

### *Installation location*

Before installing the switch, plan its location and orientation relative to other devices and equipment. For cooling purposes, allow a minimum of six inches of space between the sides, front, and the back of the chassis and walls or other obstructions. If a chassis is installed within a perforated enclosure, the perforations must have openings of at least 60 percent of the surface.

If you will be using a mechanical lift to move and install the chassis, make sure you allow enough working room.

### Unpacking a BigIron RX-16 switch

The BigIron RX-16 switch ships with several items. Review the list below, and verify the contents. If any items are missing, contact the place of purchase:

- BigIron RX-16 chassis with the appropriate number of switch fabric modules already installed in the slot marked SF and a slot blank installed in all other module slots.
- Rack mount kit, including two L-shaped brackets and mounting screws.

---

#### NOTE

You must provide standard #12-24 pan-head screws for mounting the BigIron RX Series chassis into a rack.

---

- CD-ROM containing software images and the user documentation (including this guide).
- Warranty card.
- A 115V AC power cable for each AC power supply you purchase from Brocade.

Follow the steps given below to unpack a BigIron RX-16 chassis.

1. Move the pallet to a staging area as close to the installation site as possible.
2. Position the shipping carton with the arrows pointing up.
3. Remove the strap that secures the shipping carton to the pallet.
4. Remove the plastic cover and shipping carton.
5. Save the shipping carton, pallet, and packing materials in case you need to move or ship the chassis at a later time.

### Chassis lifting guidelines for BigIron RX-16 switches



#### **DANGER**

***A fully-populated BigIron RX-16 chassis is heavy. TWO OR MORE PEOPLE ARE REQUIRED WHEN LIFTING, HANDLING, OR MOUNTING THESE DEVICES.***

---

Follow these guidelines for lifting and moving a BigIron RX-16 chassis switch:

- Before lifting or moving the switch, disconnect all external cables.
- Do not attempt to lift a fully configured switch by yourself. Using a mechanical lift to maneuver the switch into a rack is recommended. If a lift cannot be used, a minimum of four people must lift the switch, and you must remove components from the chassis before lifting.



## Installing a BigIron RX-16 chassis in a rack

### *Preparing to mount a BigIron RX-16 chassis in a rack*

Keep the following in mind when mounting a BigIron RX-16 chassis in a rack:



#### **DANGER**

*A fully-populated BigIron RX-16 chassis is heavy. TWO OR MORE PEOPLE ARE REQUIRED WHEN LIFTING, HANDLING, OR MOUNTING THESE DEVICES. Do not use the handles on the power supply units to lift or carry chassis devices.*



#### **DANGER**

*Make sure the rack or cabinet housing the device is adequately secured to prevent it from becoming unstable or falling over.*



#### **DANGER**

*Mount the devices you install in a rack or cabinet as low as possible. Place the heaviest device at the bottom and progressively place lighter devices above.*

Because of the weight of a fully loaded BigIron RX-16 chassis, Brocade recommends mounting a chassis in a rack before installing the modules and AC power supplies.

In a standard 19-inch (EIA310-D) rack, you can install up to three BigIron RX-16 chassis.

For each BigIron RX-16 chassis that you install in a rack, you must provide four standard #12-24 pan-head screws with which to mount and secure the chassis. Before performing this task, you should have an assembled rack and a #2 Phillips-head screwdriver.

This section describes the following tasks:

- [“Attaching mounting brackets to a BigIron RX-16 chassis”](#)
- [“Mounting a BigIron RX-16 chassis in a rack”](#)
- [“Removing the slot blanks”](#)

### *Attaching mounting brackets to a BigIron RX-16 chassis*

The BigIron RX-16 chassis ships with a rack mount kit. The kit includes two L-shaped mounting brackets and mounting screws.

The chassis sides have two sets of screw holes: one set for attaching the mounting brackets close to the chassis front and another set for attaching the brackets toward the chassis center.

Attach the mounting brackets to the sides of the chassis as illustrated in [Figure 33](#).

---

#### **NOTE**

The diagram shows locations for attaching the mounting brackets for either front-mount or mid-mount of the BigIron RX-16 chassis.

---

### ***Mounting a BigIron RX-16 chassis in a rack***

Follow the steps given below to mount a BigIron RX-16 chassis in a rack.

1. Determine the position of each chassis in the rack, for example, a chassis with the fewest modules on top, a chassis with more modules than the top chassis in the middle, and a fully populated chassis on the bottom.
2. Position the four screws for each chassis according to the spacings of the keyhole slots (the ones with the narrow portion pointing upwards) on the mounting brackets as shown in [Figure 34](#). Do not secure the screws completely; leave approximately 1/4 inch of clearance between the back of the screw head and the rack.

**FIGURE 33** Positioning the screws in a rack

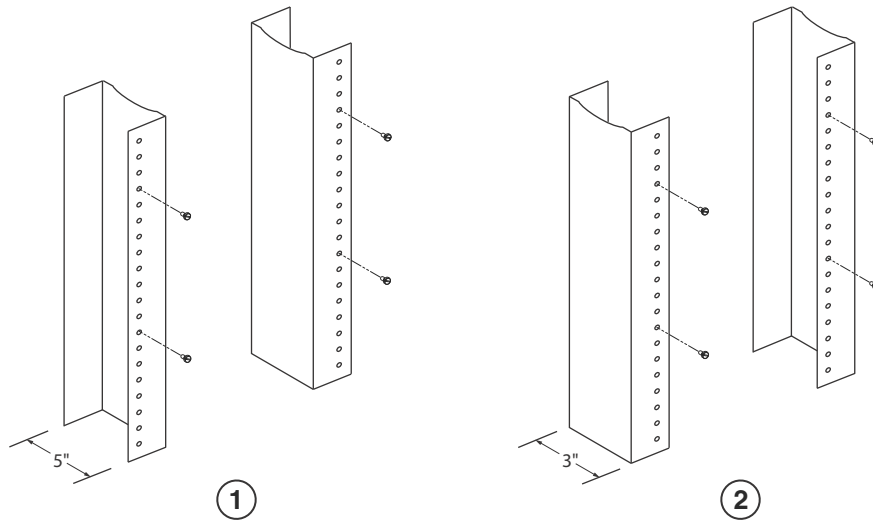

1 Unequal flange equipment rack

2 Network equipment rack

3. Starting with the chassis that you want to mount in the lowest position in the rack, mount the chassis in the rack as shown in [Figure 34](#). With two or more people lifting the chassis, slip the wide portion of each keyhole slot over the corresponding screw in the rack.

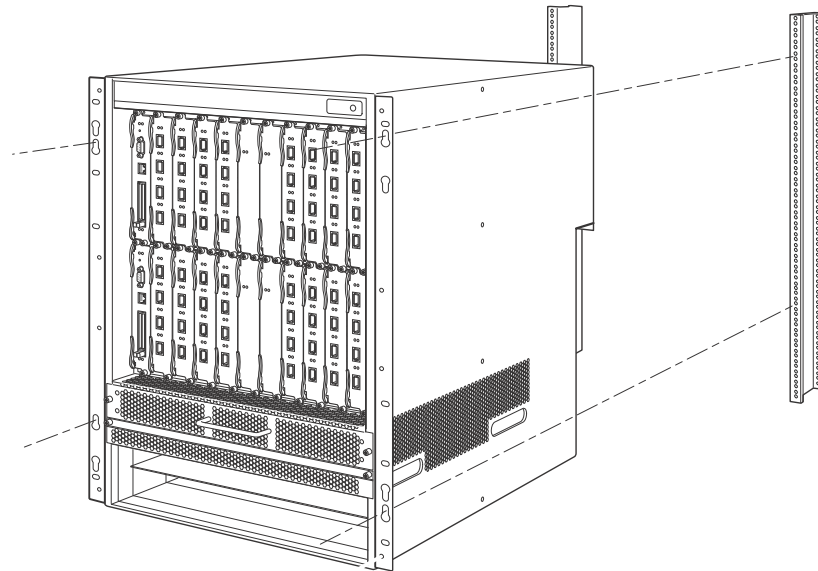
**FIGURE 34** Mounting the BigIron RX-16 or BigIron RX-32 chassis in a rack

4. Slide the chassis down so that the screw heads are in the narrow portion of the keyhole slots.
5. Tighten the screws to secure the chassis in place.

**NOTE**

To provide better grounding of the chassis to the rack, attach the chassis to the rack using star washers. Additionally, if any single hole grounding lugs are used star washers shall be used as a means to prevent rotation of the lug.

6. Repeat [step 2](#) through [step 5](#) to mount each subsequent chassis in the same rack.

***Removing the slot blanks***

The BigIron RX-16 chassis ships with slot blanks installed in all module slots. The slot blank covers a slot that does not currently have a module installed in it, ensuring proper airflow within the chassis. If you plan to install a module in a particular slot, you must remove the slot blank.

**CAUTION**

**If you do not install a module in a slot, you must keep the slot blank in place. If you run the chassis with an uncovered slot, the system may overheat. Tighten the screws that secure the slot blanks so that they remain in place when removing adjacent panels or modules.**

Although the slot blanks are different in size, the procedure for removing them from the BigIron RX Series chassis is the same. Therefore, this section provides one procedure that applies to all slot blanks.

You will need a flat-head screwdriver to perform this task.

Follow the steps given below to remove a slot blank.

1. Loosen the screws on either end of the slot blank by hand or with a flat-head screwdriver.
2. Pull the slot blank out of the chassis, and store it in a safe place for future use.

## Installing BigIron RX-16 modules

This section provides one procedure that applies to all modules. The sequence for installing more than one module is important to ensure proper fit. For the BigIron RX-16 chassis, starting with the lowest row, and moving upwards, install the modules left-to-right starting with the bottom row

---

### NOTE

The BigIron RX Series modules are dedicated, which means that you must install them in the BigIron RX Series chassis only. For example, if you attempt to install the BigIron RX Series management module in another Brocade chassis or a management module intended for another Brocade chassis in the BigIron RX Series chassis, the chassis and module will not function properly.

---

Table 12 provides the chassis slot numbers into which you must install the modules. Markings for the chassis slots appear at the base of the slots.

**TABLE 12** BigIron RX-16 module installation

BigIron RX-16 module	Chassis slot number
Management modules	Active module – M1 (upper). Redundant module – M2 (lower).
Interface modules	1 – 16
Switch Fabric modules	SF1 – SF4

The BigIron RX-16 chassis ships with the required switch fabric modules installed.



### CAUTION

**If you do not install a module in a slot, you must leave the slot blank installed in the slot. If you run the BigIron RX-16 chassis with an uncovered slot, the system may overheat.**

If you are installing a redundant management module, refer to the *Using a Redundant Management Module* chapter in the *BigIron RX Series Configuration Guide* for information about how the redundant module works, optional software configurations that you can perform, and how to manage the redundancy feature.

Before installing a module in the BigIron RX-16 chassis, have the following on hand:

- An ESD wrist strap with a plug for connection to the ESD connector on the BigIron RX Series chassis.



### DANGER

**For safety reasons, the ESD wrist strap should contain a 1 meg ohm series resistor.**

- A large flat-head screwdriver.

Follow the steps given below to install a module in the BigIron RX-16 chassis.

1. Put on the ESD wrist strap and ground yourself by inserting the plug into the ESD connector on the chassis front.
2. Remove the module from its packaging.

3. With the ejectors in the outward position, insert the module into the appropriate chassis slot and slide the card along the card guide until the ejectors on either side of the module move close to the module front panel. Refer to special instructions, “[Populating a BigIron RX-16 chassis](#)” on page 53.

**NOTE**

When inserting the module into the chassis, make sure that the faceplate does not overlap with the faceplate of an adjacent interface module.

4. Push the ejectors in until they are flush with the module front panel. This action will fully seat the module in the backplane. Modules have a snug fit for maximum EMI protection.

**FIGURE 35** Installing a module in a BigIron RX-16 chassis

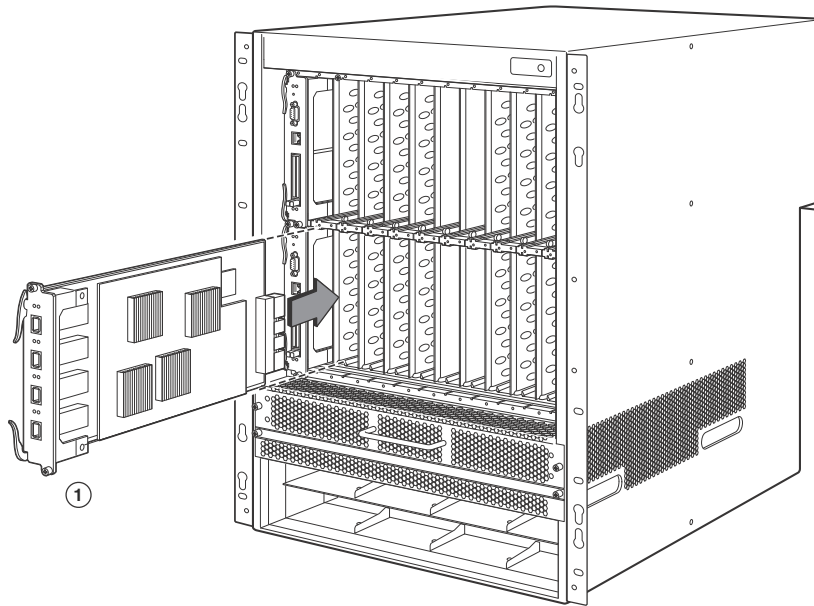

- 1 Interface module

**NOTE**

The installation instructions for installing modules shown in the following illustrations are exactly the same for interface, management, and switch fabric modules.

5. Tighten the two screws at either end of the module front panel by pushing them in and turning them clockwise. Then, tighten the screws further using the flat-head screwdriver.

### ***Populating a BigIron RX-16 chassis***

The sequence for installing more than one card is important to ensure proper fit in the BigIron RX-16 chassis. Always fill the bottom slots in the BigIron RX-16 first. Begin by filling the slots from the left side of the chassis, and working your way towards the right. Refer to “[BigIron RX-16 chassis](#)” on page 4 for slot locations.

**NOTE**

Any empty slots must contain slot blanks to ensure proper air flow within the chassis.

## 2 Installing a BigIron RX-16 switch

### *Rules for populating a BigIron RX-16 chassis*

1. Install a management module in management slot 2.
2. Install interface modules in interface slots 2, 4, 6, and 8.
3. Install switch fabric modules in the switch fabric slots 2 and 4.
4. Install interface modules in interface slots 10, 12, 14, and 16.
5. Install a management module in management slot 1.
6. Install interface modules in interface slots 1, 3, 5, and 7.
7. Install switch fabric modules in the switch fabric slots 1 and 3.
8. Install interface modules in interface slots 9,11,13, and 15.

### Installing power supplies in a BigIron RX-16 chassis

Follow the steps given below to install a power supply in a BigIron RX-16 chassis.

1. Remove the blank power supply faceplate, and expose the empty power supply slot.
2. Remove the power supply from its packaging.
3. Insert the power supply into the empty power supply slot, using the guides provided on either side of the slot.

**FIGURE 36** Installing a power supply in a BigIron RX-16 chassis

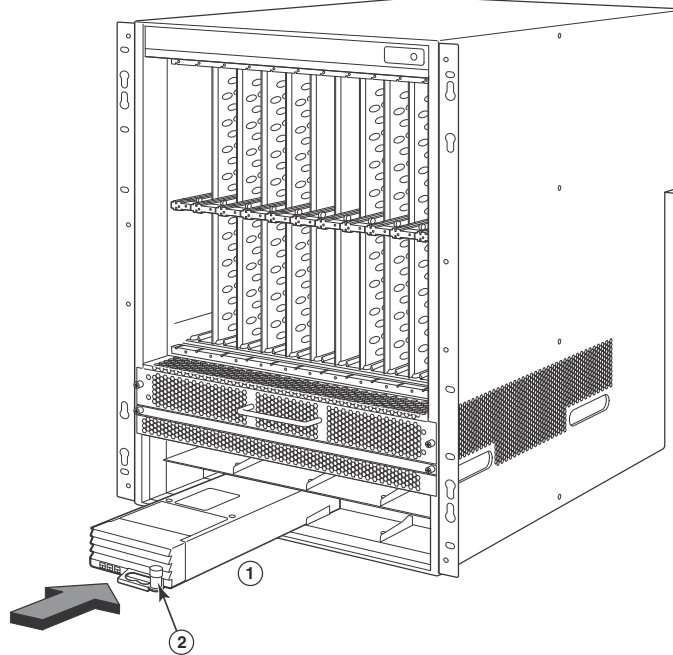

1 Power supply

2 Release latch

**CAUTION**

Carefully follow the mechanical guides on each side of the power supply slot and make sure the power supply is properly inserted in the guides. Never insert the power supply upside down.

4. After the power supply is fully inserted, push the power supply front panel toward the back of the chassis. This action causes the power supply connector to latch into the backplane connector.
5. For information about connecting power to the chassis, refer to [“Connecting AC power to a BigIron RX-16 chassis”](#) below.
6. For information about powering on the system, refer to [“Powering on the power source”](#) on page 79.

## Connecting AC power to a BigIron RX-16 chassis

AC power is supplied through an AC power cord that is installed at the rear of the BigIron RX-16 chassis.

1. At the rear of the BigIron RX-16 chassis, locate the power receptacle where the power supplies have been installed.
2. Lift the cord-retainer and connect a Brocade-supplied AC power cord to the power supply.
3. Snap the cord-retainer over the power plug to hold it in place.

**FIGURE 37** Connecting a power cord to the power supply in a BigIron RX-16 chassis

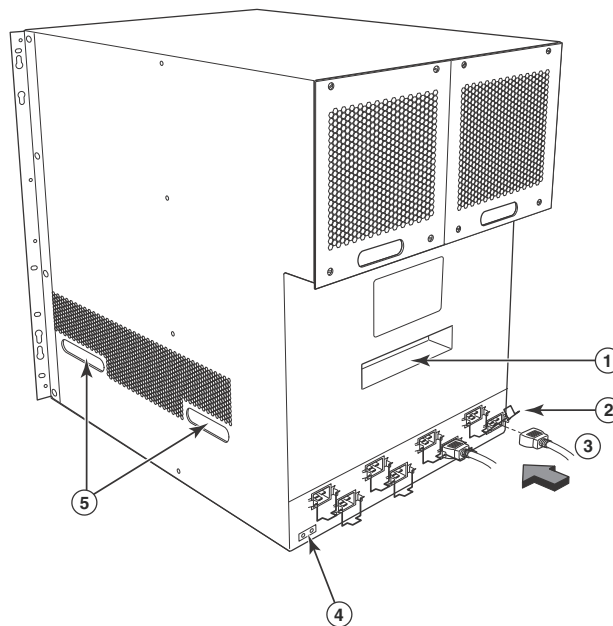

- |   |               |   |              |
|---|---------------|---|--------------|
| 1 | Lift handle   | 4 | Ground point |
| 2 | Cord retainer | 5 | Lift handles |
| 3 | Power cord    |   |              |



### **DANGER**

*If the installation requires a different power cord than the one supplied with the device, make sure you use a power cord displaying the mark of the safety agency that defines the regulations for power cords in your country. The mark is your assurance that the power cord can be used safely with the device.*

4. For information about powering on the system, refer to [“Powering-on the power source”](#) on page 79.

## Connecting DC power to a BigIron RX-16 chassis

You can use a DC power source for the BigIron RX-16 chassis. This is supported through use of a DC-to-DC power supply. DC power must be supplied at 48 V and 30 A. The DC-to-DC supply provides the DC power to the chassis at 12 V and 100 A.



### **DANGER**

*The procedure in this section is for qualified service personnel.*

Follow the steps given below to connect a DC power source.

1. Use a flat-blade screwdriver to remove the two screws holding the transparent cover over the power supply lugs.

**FIGURE 38** The BigIron RX-8 and BigIron RX-16 DC power supply

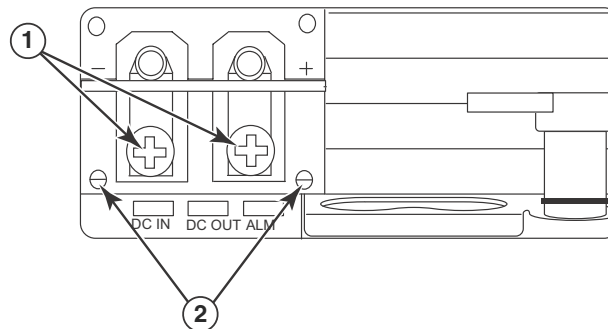

1 Screws holding power lugs

2 Screws holding transparent cover

2. Use a Phillips head screwdriver to remove each of the power lugs.
3. Crimp #8 AWG power supply wire into the power lugs and reconnect the power lugs to the power supply unit.

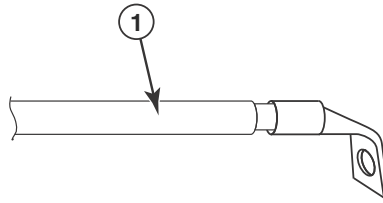

**FIGURE 39** Crimping the power supply wire in the lug

1. #8 AWG power supply wire
4. Re-attach the transparent cover over the power supply lugs that was removed in Step 1.
5. Connect the wire to your DC power source, making sure to connect the -48V cable to the negative terminal on the power supply and the 0V cable to the positive terminal as marked on the power supply.

## Final steps

Follow the steps listed below to complete the installation:

- [“Attaching a management station”](#)
- [“Powering-on the power source”](#)
- [“Verifying proper operation”](#)

## Installing a BigIron RX-32 switch

This section describes the following tasks:

- [“Preparing the installation site”](#)
- [“Unpacking a BigIron RX-32 switch”](#)
- [“Installing a BigIron RX-32 chassis in a rack”](#)
- [“Installing BigIron RX-32 modules”](#)
- [“BigIron RX-32 cable routing”](#)
- [“Installing power supplies in a BigIron RX-32 chassis”](#)
- [“Connecting AC power to a BigIron RX-32 chassis”](#)
- [“Final steps”](#)

## Preparing the installation site

### *Cabling infrastructure*

Ensure that the proper cabling is installed in the site.

For information on cabling, refer to [“BigIron RX-32 cable routing”](#) on page 67, [“Installing power supplies in a BigIron RX-32 chassis”](#) on page 75, [“Attaching a management station”](#) on page 77, and [“Connecting a BigIron RX Series switch”](#) on page 105.

### *Installation location*

Before installing the switch, plan its location and orientation relative to other devices and equipment. For cooling purposes, allow a minimum of six inches of space between the sides, front, and the back of the chassis and walls or other obstructions. If a chassis is installed within a perforated enclosure, the perforations must have openings of at least 60 percent of the surface.

Since you will be using a mechanical lift to move and install the chassis, make sure you allow enough working room.

---

**NOTE**

Make sure your site provides 200-240 AC power.

---

### **Unpacking a BigIron RX-32 switch**

The BigIron RX-32 switch ships with several items. Review the list below, and verify the contents. If any items are missing, contact the place of purchase:

- BigIron RX-32 chassis with the card slots empty, and covered with upper and lower shipping panels (refer to uncrating instructions next)
- The appropriate number of interface modules, switch fabric modules, management modules, and power supplies shipped separately
- A total of 32 slot blanks shipped separately
- Rack mount kit, including two L-shaped brackets and mounting screws

---

**NOTE**

You must provide standard #12-24 pan-head screws for mounting the BigIron RX Series chassis into a rack.

---

- Insertion or extraction tool for use with RJ-45 and fiber-optic connectors
- CD-ROM containing software images and the user documentation (including this guide)
- Warranty card
- A 220-240V AC power cable for each AC power supply you purchase from Brocade

### *Uncrating the BigIron RX-32 chassis*

Before uncrating the chassis, the site should be prepared as described in [“Preparing the installation site”](#) on page 57. You will need the following tools:

- A forklift or pallet jack to move the chassis while still on the pallet (at least 550-lb limit)
- A mechanical lift (at least 350-lb limit) for moving the chassis off the pallet. The ideal configuration is a counterweight base material lift with a metal lift plate installed in place of the forks. The metal plate should be no wider than 17 inches, so that it will fit between the rack mount rails.
- A strap to stabilize the chassis while being moved on the mechanical lift
- A power drill
- A large Phillips screwdriver attachment
- A 7/16-inch socket wrench attachment

The BigIron RX-32 chassis ships in a wooden crate, bolted to an inner pallet, and resting on an outer pallet. Follow the steps given below to uncrate the chassis.

---

**NOTE**

To uncrate the BigIron RX-32 chassis, the crate must be in the upright (vertical) position.

---

1. Position the crate so that you have access to the front and the rear. There must be enough space to the rear of the pallet to slide and remove the crate.
2. Use a power drill with Phillips and large blade screwdriver attachments to remove the bolts and screws that hold the front shipping panel in place, as shown in [Figure 40](#). Remove the front shipping panel and set it aside.

**FIGURE 40** Removing bolts and screws on the BigIron RX-32 chassis

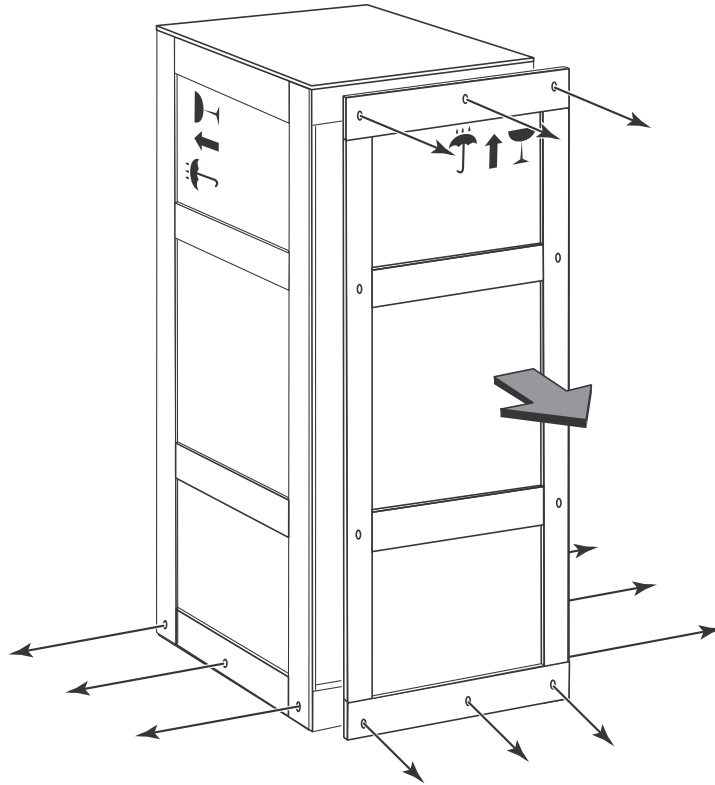

3. Remove the remaining bolts and screws along the bottom of the crate that attach the crate to the pallet.
4. Slide the sides, top, and back of the crate backwards as one unit until it clears the pallet.
5. Save the crate (including the shipping panel) in case the chassis needs to be shipped again.

## Installing a BigIron RX-32 chassis in a rack

This section describes the following tasks:

- Preparing to Mount a BigIron RX-32 chassis in a Rack
- Attaching mounting brackets to a chassis

- Mounting a BigIron RX-32 chassis in a rack

### ***Preparing to mount a BigIron RX-32 chassis in a rack***

Keep the following in mind when mounting a BigIron RX-32 chassis in a rack:



#### **DANGER**

***Make sure the rack or cabinet housing the device is adequately secured to prevent it from becoming unstable or falling over.***



#### **DANGER**

***Mount the devices you install in a rack or cabinet as low as possible. Place the heaviest device at the bottom and progressively place lighter devices above.***

Because of the weight of a fully loaded BigIron RX-32 chassis, Brocade recommends mounting the chassis in a rack before installing the modules and AC power supplies.

In a standard 19-inch (EIA310-D) rack, you can install one BigIron RX-32 chassis.

For each BigIron RX-32 chassis that you install in a rack, you must provide eight standard #12-24 pan-head screws with which to mount and secure the chassis. Before performing this task, you should have an assembled rack and a #2 Phillips-head screwdriver.

### ***Attaching mounting brackets to a BigIron RX-16 or BigIron RX-32 chassis***

The BigIron RX-16 and BigIron RX-32 chassis ship with a rack mount kit that contains two L-shaped mounting brackets and mounting screws.

The chassis sides have two sets of screw holes: one set for attaching the mounting brackets close to the chassis front, and another set for attaching the brackets toward the chassis center.

Attach the mounting brackets to the sides of the chassis as illustrated in [“Mounting the BigIron RX-16 or BigIron RX-32 chassis in a rack”](#) on page 51.

---

#### **NOTE**

The diagram shows locations for attaching the mounting brackets for either front-mount or mid-mount of the BigIron RX-16 chassis. Mounting brackets for the BigIron RX-32 chassis are attached in the same manner.

---

### ***Mounting a BigIron RX-32 chassis in a rack***

Due to its larger size, the BigIron RX-32 chassis has some requirements different from the other BigIron RX Series chassis. Use the following procedural changes when installing a BigIron RX-32 chassis:

- Only one BigIron RX-32 chassis can be mounted in a rack, positioned as low as possible.
- The empty BigIron RX-32 chassis weighs approximately 325 lbs. You must use a mechanical device (such as a material lift or work positioner), and four people are required to guide the chassis into place.

Follow the steps given below to install a BigIron RX-32 chassis.

1. Ensure the rack is in its permanent location and is secured to the building. Ensure that the installation site allows adequate clearance for both airflow, installation, and maintenance.
2. Move the pallet and chassis as close to the installation site as possible.
3. Use a power drill with a large Phillips screwdriver attachment to remove the four L-brackets that attach the base of the chassis to the inner pallet. Refer to [Figure 41](#).

**FIGURE 41** Location of L-Brackets holding the BigIron RX-32 chassis

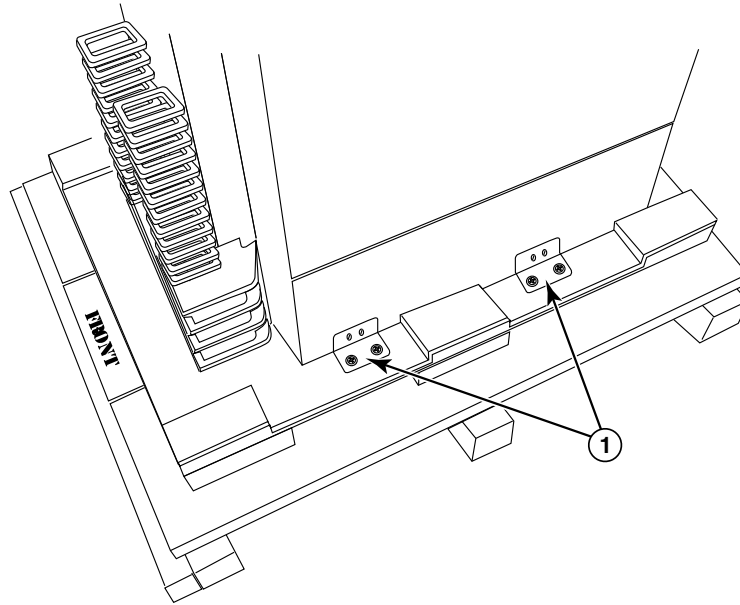

1. Remove brackets that hold chassis to base (two brackets on either side of chassis)
4. Using a mechanical lift equipped with a lift plate, position the lift plate as close to the front of the chassis as possible. Adjust the lift plate height to be even with the bottom of the chassis.
5. Slide the chassis onto the lift plate.



**DANGER**

***Four or more people are required to position the unpopulated chassis into the rack.***



**DANGER**

***Do not use the handles on the power supply units or fan modules to position the chassis.***

6. Secure the chassis to the mechanical lift with a strap to prevent tipping.
7. Carefully move the chassis and position it in front of the rack where it is to be installed.
8. Remove the strap securing the chassis to the lift.
9. With two people in front and two people in back, slide the chassis into the rack.

## 2 Installing a BigIron RX-32 switch

10. If you are installing the chassis in a four-post rack or cabinet, install a mounting screw and a cage nut into each of the holes aligned with the threaded holes in the spacer bars. If you are installing the chassis in an open-frame rack, install four standard #12-24 pan-head screws into the keyhole mounting holes aligned with the rack.
11. Visually inspect the alignment of the chassis. If the chassis is installed properly in the rack, all the mounting screws on one side of the rack should be aligned with the mounting screws on the opposite side and the switch should be level.
12. Add all additional screws.

### Installing BigIron RX-32 modules

The BigIron RX-32 ships with empty module slots, and upper and lower shipping panels installed.



#### **CAUTION**

**If you do not install a module in a slot, you must leave the slot blank installed in the slot. If you run the BigIron RX-32 chassis with an uncovered slot, the system may overheat.**

---

#### **NOTE**

The BigIron RX Series modules are dedicated, which means that you must install them in the BigIron RX Series chassis only. For example, if you attempt to install the BigIron RX Series management module in another Brocade chassis or a management module intended for another Brocade chassis in the BigIron RX Series chassis, the chassis and module will not function properly.

If you are installing a redundant management module, refer to *Using a Redundant Management Module* chapter in the *BigIron RX Series Configuration Guide* for information about how the redundant module works, optional software configurations that you can perform, and how to manage the redundancy feature.

Before installing a module in the BigIron RX-32 chassis, have the following on hand:

- An ESD wrist strap with a plug for connection to the ESD connector on the BigIron RX-32 chassis.



#### **DANGER**

***For safety reasons, the ESD wrist strap should contain a 1 meg ohm series resistor.***

- A large flat-head screwdriver.

Follow the steps given below to install a module in the BigIron RX-32 chassis.

1. Put on the ESD wrist strap and ground yourself by inserting the plug into the ESD connector on the chassis front.
2. Remove the module from its packaging.
3. Remove the two shipping panels by unscrewing the six captive screws holding each panel.
4. With the ejectors in the outward position, insert the module into the appropriate chassis slot and slide the card along the card guide until the ejectors on either side of the module move close to the module front panel. Refer to special instructions, "[BigIron RX-32 cable routing](#)" on page 67.

---

**NOTE**

When inserting the module into the chassis, make sure that the faceplate does not overlap with the faceplate of an adjacent interface module.

---

5. Push the ejectors in until they are flush with the module front panel. This action will fully seat the module in the backplane. Modules have a snug fit for maximum EMI protection.

**FIGURE 42** Installing a module in a BigIron RX-32 chassis

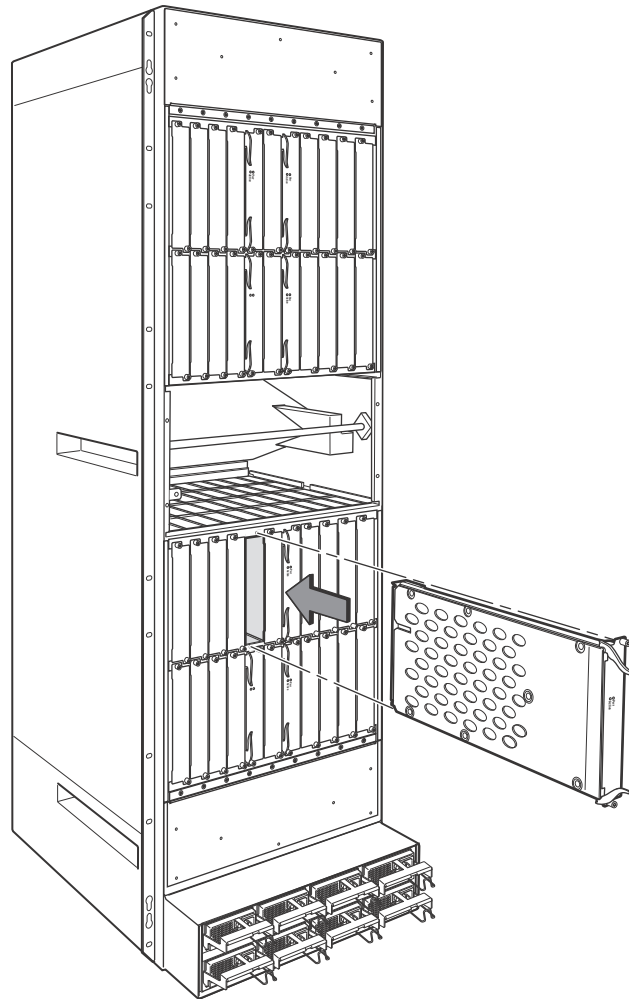

---

**NOTE**

The installation instructions for installing modules shown in the following illustrations are exactly the same for interface, management, and switch fabric modules.

---

6. Tighten the two screws at either end of the module front panel by pushing them in and turning them clockwise. Then, tighten the screws further using the flat-head screwdriver.

### *BigIron RX-32 module installation details*

---

**NOTE**

Do not insert interface modules running releases below 02.3.00 into slots 17 to 32 of a BigIron RX-32 chassis. They should only be inserted into slots 1 to 16.

---

---

**NOTE**

Any empty slots must contain slot blanks to ensure proper air flow within the chassis.

---

---

**NOTE**

During the initially installation of the modules into a BigIron RX-32, Brocade recommends inserting all the modules into the appropriate chassis slots before tightening the screws into the chassis.

---

When Populating the BigIron RX-32 chassis, the modules must be installed in the appropriate slots as shown in [Figure 43](#) as follows:

- Management Modules: management slots 1 and 2
- Switch Fabric Modules: switch fabric slots 1-8
- Interface Modules: Interface slots 1-32



FIGURE 43 BigIron RX-32 chassis

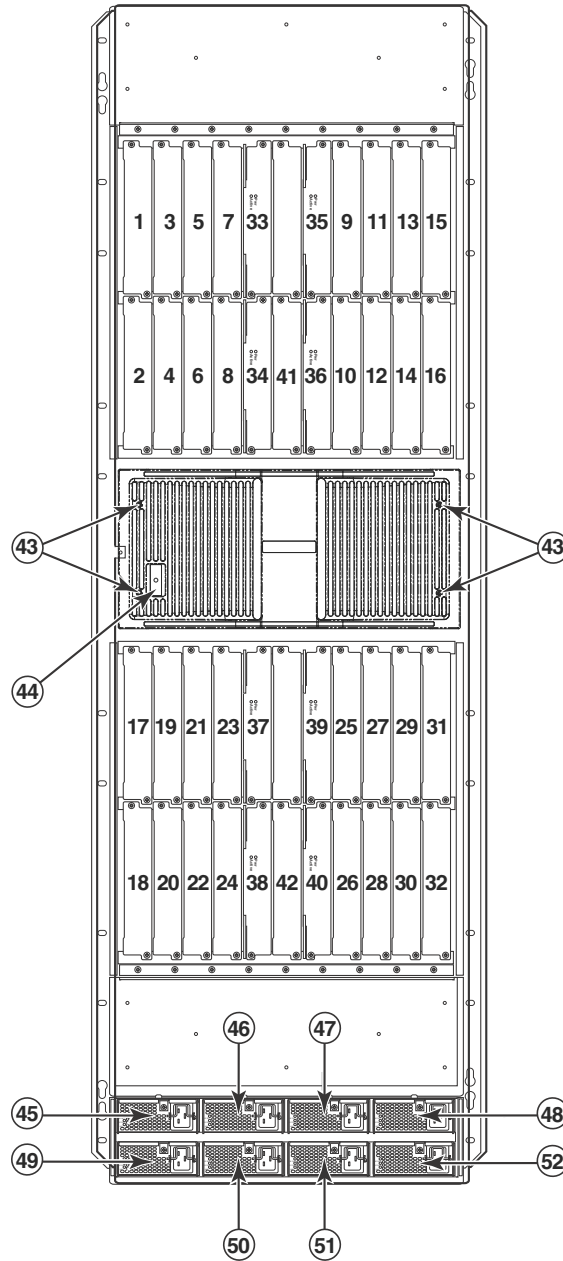

- |   |                  |    |                      |
|---|------------------|----|----------------------|
| 1 | Interface slot 1 | 27 | Interface slot 27    |
| 2 | Interface slot 2 | 28 | Interface slot 28    |
| 3 | Interface slot 3 | 29 | Interface slot 29    |
| 4 | Interface slot 4 | 30 | Interface slot 30    |
| 5 | Interface slot 5 | 31 | Interface slot 31    |
| 6 | Interface slot 6 | 32 | Interface slot 32    |
| 7 | Interface slot 7 | 33 | Switch fabric slot 1 |

## 2 Installing a BigIron RX-32 switch

8	Interface slot 8	34	Switch fabric slot 2
9	Interface slot 9	35	Switch fabric slot 3
10	Interface slot 10	36	Switch fabric slot 4
11	Interface slot 11	37	Switch fabric slot 5
12	Interface slot 12	38	Switch fabric slot 6
13	Interface slot 13	39	Switch fabric slot 7
14	Interface slot 14	40	Switch fabric slot 8
15	Interface slot 15	41	Management slot 1
16	Interface slot 16	42	Management slot 2
17	Interface slot 17	43	Captive screws
18	Interface slot 18	44	ESD strap connector
19	Interface slot 19	45	Power supply 1
20	Interface slot 20	46	Power supply 2
21	Interface slot 21	47	Power supply 3
22	Interface slot 22	48	Power supply 4
23	Interface slot 23	49	Power supply 5
24	Interface slot 24	50	Power supply 6
25	Interface slot 25	51	Power supply 7
26	Interface slot 26	52	Power supply 8

### *Using the Insertion or Extraction tool*

Due to the high density of cables that the BigIron RX-32 chassis can support, it may be difficult to insert and remove the RJ-45 and optical connectors. An insertion or extraction tool has been provided in the BigIron RX-32 accessory kit to make this task easier. Refer to [Figure 44](#).

**FIGURE 44** Insertion or extraction tool

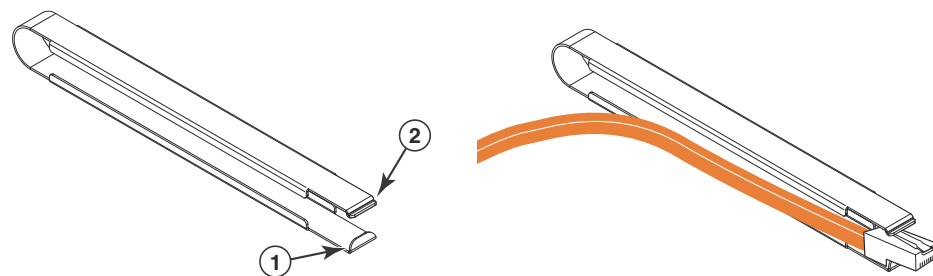

1 Hooked tab

2 Stepped tab

Use the tool to grasp the boot or the plug of the modular connector at its narrow end (the end closest to the attached cable), and insert the connector into the proper interface module. Grasping the boot or plug at the wide end during insertion may cause the tool to be difficult to release and remove.

When using the tool to extract the boot or plug of a modular connector, cover the entire length of the boot or plug with the tool. Notice that one end of the tool has a "hook" side. Use this side to compress the locking tab while you remove the connector.

## BigIron RX-32 cable routing

BigIron RX-32 cable management is designed to ensure access to the power supplies at the bottom of the chassis, and to keep the air inlet clear in the center of the chassis (this is essential for proper cooling). Cable management hardware at the top, bottom and sides of the chassis will assist you in channeling the cables in the proper direction.

In general, cables from the outer interface modules are routed horizontally and away from the chassis. With the cable management upper cover swung open, cables from the remaining modules in the upper half of the chassis are routed up, then outwards along the channels.

With the cable management lower cover swung open, the remaining modules in the lower half of the chassis follow a similar path downwards, above the power supplies. [Figure 45](#) diagrams the cable routing, with the upper and lower covers removed for clarity.

**FIGURE 45** BigIron RX-32 cable routing diagram

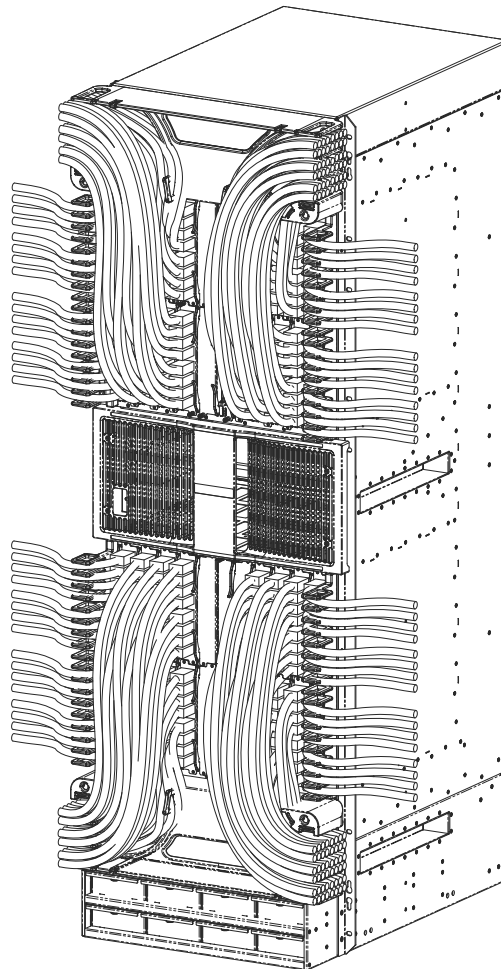

## 2 Installing a BigIron RX-32 switch

Details of cable routing are as follows:



### CAUTION

Be sure not to exceed the minimum recommended bend radius for the cables: 2 in. for MRJ-21 cables, and 1.5 in. for Category 5 (RJ-45) and fiber-optic cables.

### *Cable routing for the upper-left quadrant*

Route slot cards in the numerical order starting with the cables of Slot Card #1.

1. Route slot cards #1 and #2 cables directly to the left through the side comb. Refer to [Figure 46](#).

**FIGURE 46** Routing upper-left quadrant cables to the left

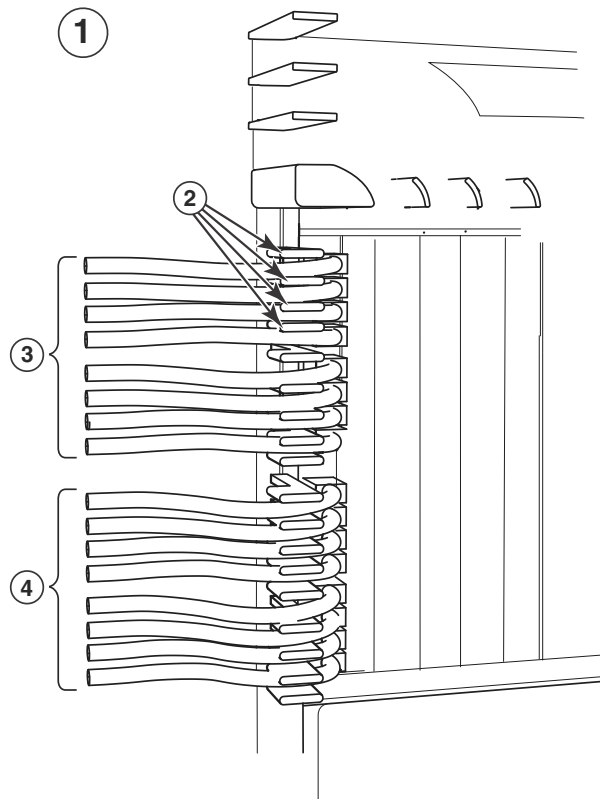

- |   |                     |   |                     |
|---|---------------------|---|---------------------|
| 1 | Upper left quadrant | 3 | Cables from slot #1 |
| 2 | Side combs (18)     | 4 | Cables from slot #2 |

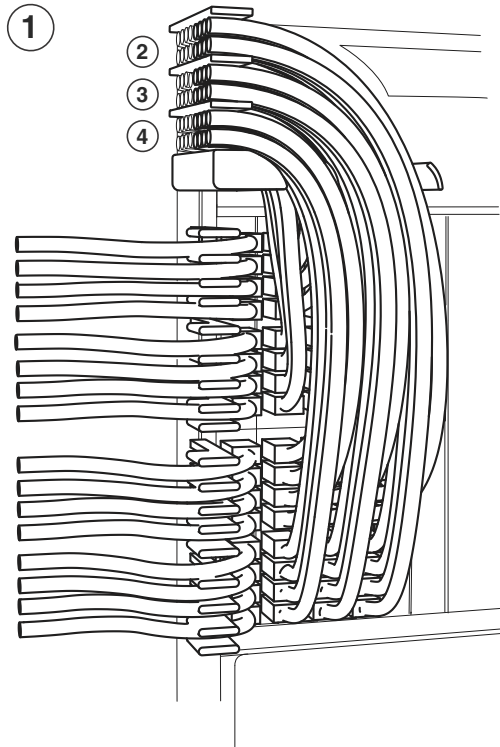
**FIGURE 47** Routing upper-left quadrant cables up

- |   |                                |   |                                |
|---|--------------------------------|---|--------------------------------|
| 1 | Upper left quadrant            | 3 | Comb B (Slot #5 and #6 cables) |
| 2 | Comb C (Slot #7 and #8 cables) | 4 | Comb A (Slot #3 and #4 cables) |

2. Route slot card #3 and #4 cables up through Comb A. Refer to [Figure 47](#).
3. Route slot card #5 and #6 cables up through Comb B.
4. Route slot card #7 and #8 cables up through Comb C.

## 2 Installing a BigIron RX-32 switch

### *Cable routing for the upper-right quadrant*

Route slot cards in the numerical order starting with the cables of Slot Card #15.

1. Route slot card #15 and #16 cables directly to the right through the side comb. Refer to [Figure 48](#).

**FIGURE 48** Routing upper-right quadrant cables to the right

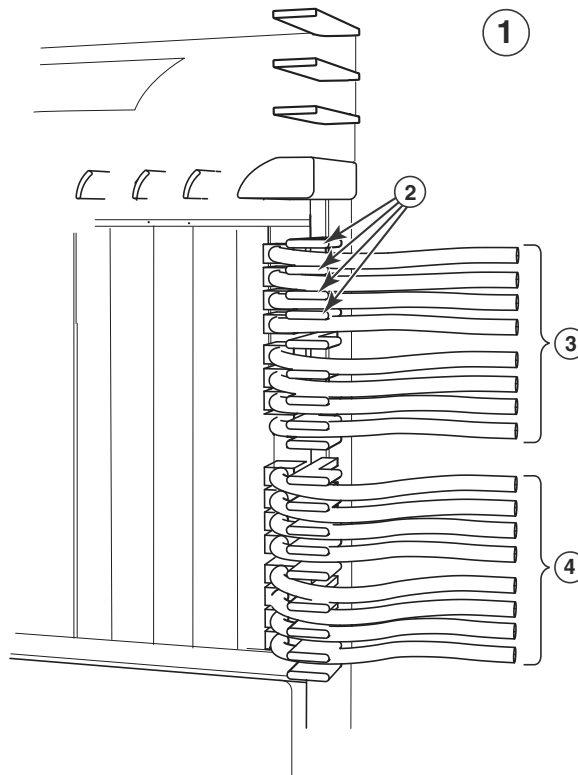

- |   |                      |   |                      |
|---|----------------------|---|----------------------|
| 1 | Upper right quadrant | 3 | Cables from slot #15 |
| 2 | Side combs (18)      | 4 | Cables from slot #16 |

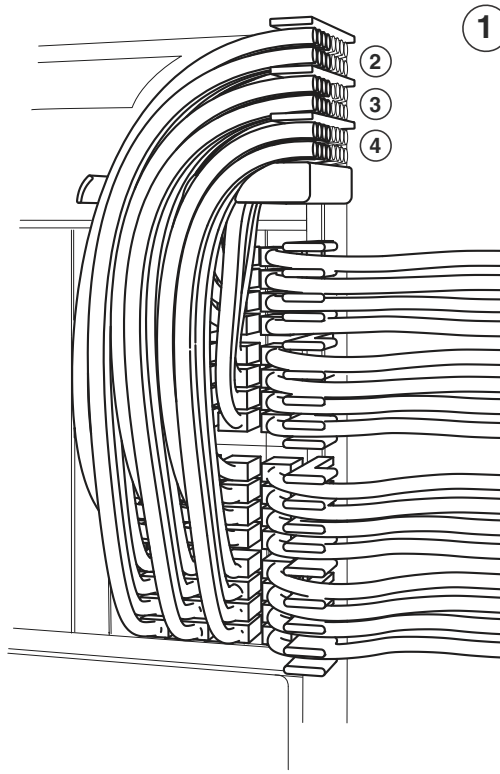
**FIGURE 49** Routing upper-right quadrant cables up

- |   |                                 |   |                                  |
|---|---------------------------------|---|----------------------------------|
| 1 | Upper right quadrant            | 3 | Comb B (Slot #11 and #12 cables) |
| 2 | Comb C (Slot #9 and #10 cables) | 4 | Comb A (Slot #13 and #14 cables) |
2. Route slot card #13 and #14 cables up through Comb A. Refer to [Figure 49](#).
  3. Route slot card #11 and #12 cables up through Comb B.
  4. Route slot card #9 and #10 cables up through Comb C.

## 2 Installing a BigIron RX-32 switch

### *Cable routing for the lower-left quadrant*

1. Route slot card #18 and #17 cables directly to the left through the side comb. Refer to [Figure 50](#).

**FIGURE 50** Routing lower-left quadrant cables to the left

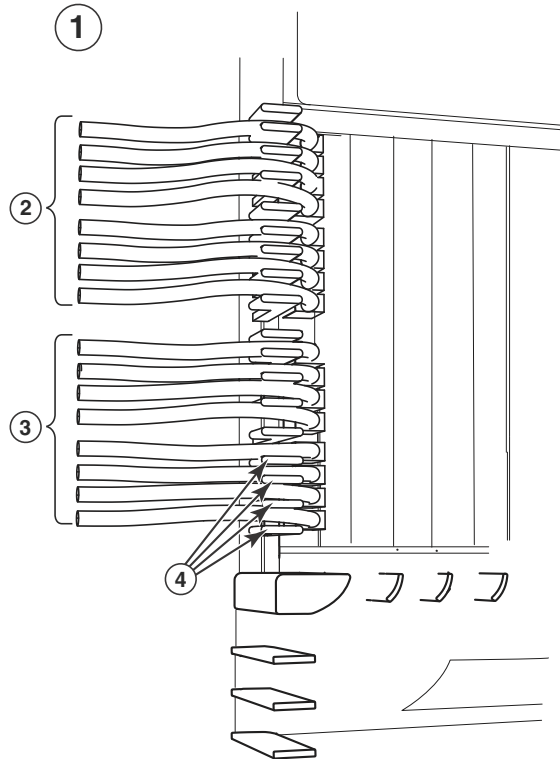

- |   |                      |   |                      |
|---|----------------------|---|----------------------|
| 1 | Lower left quadrant  | 3 | Cables from slot #18 |
| 2 | Cables from slot #17 | 4 | Side combs (18)      |

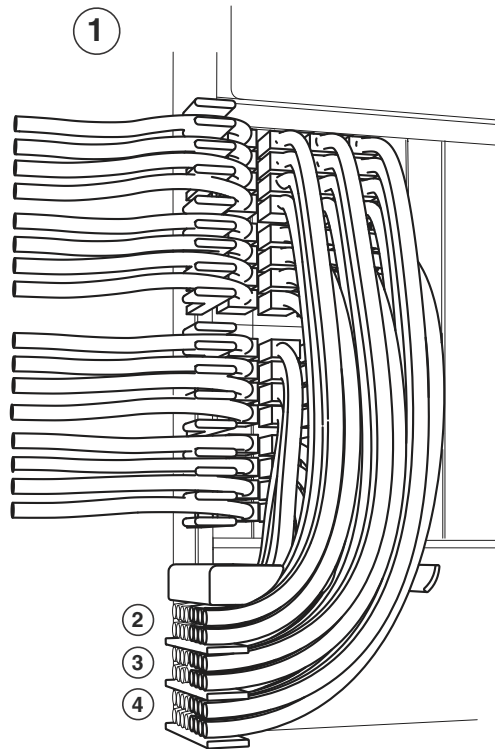

**FIGURE 51** Routing lower-left quadrant cables down

- |   |                                  |   |                                  |
|---|----------------------------------|---|----------------------------------|
| 1 | Lower left quadrant              | 3 | Comb B (Slot #21 and #22 cables) |
| 2 | Comb A (Slot #19 and #20 cables) | 4 | Comb C (Slot #23 and #24 cables) |

2. Route slot card #20 and #19 cables down through Comb A. Refer to [Figure 51](#).
3. Route slot card #22 and #21 cables down through Comb B.
4. Route slot card #24 and #23 cables down through Comb C.

## 2 Installing a BigIron RX-32 switch

### *Cable routing for the lower-right quadrant*

1. Route slot card #32 and #31 cables directly to the right through the side comb. Refer to [Figure 52](#).

**FIGURE 52** Routing the lower-right quadrant cables to the right

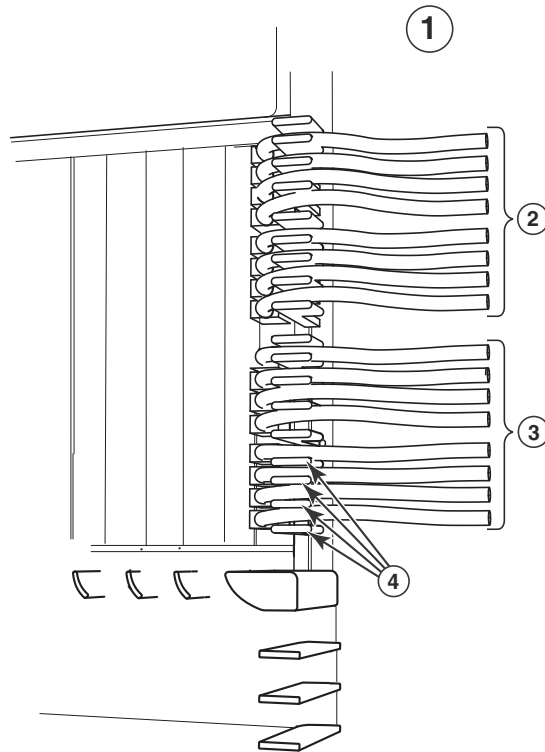

- |   |                      |   |                      |
|---|----------------------|---|----------------------|
| 1 | Lower right quadrant | 3 | Cables from slot #32 |
| 2 | Cables from slot #31 | 4 | Side combs (18)      |

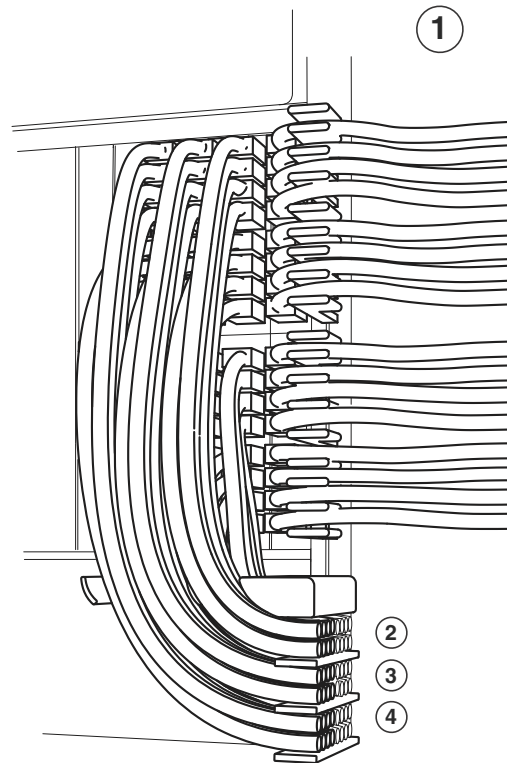
**FIGURE 53** Routing lower-right quadrant cables down

- |   |                                  |   |                                  |
|---|----------------------------------|---|----------------------------------|
| 1 | Lower right quadrant             | 3 | Comb B (Slot #27 and #28 cables) |
| 2 | Comb A (Slot #29 and #30 cables) | 4 | Comb C (Slot #25 and #26 cables) |

2. Route slot card #30 and #29 cables down through Comb A. Refer to [Figure 53](#).
3. Route slot card #28 and #27 cables down Comb B.
4. Route slot card #26 and #25 cables down through Comb C.

## Installing power supplies in a BigIron RX-32 chassis



### **DANGER**

***High Touch Current. Earth connection essential before connecting supply.***

Follow the steps given below to install a power supply in a BigIron RX-32 chassis.

1. Remove the blank power supply faceplate, and expose the empty power supply slot.
2. Remove the power supply from its packaging.
3. Insert the power supply into the empty power supply slot, using the guides provided on either side of the slot.

## 2 Installing a BigIron RX-32 switch

FIGURE 54 Installing a power supply in a BigIron RX-32 chassis

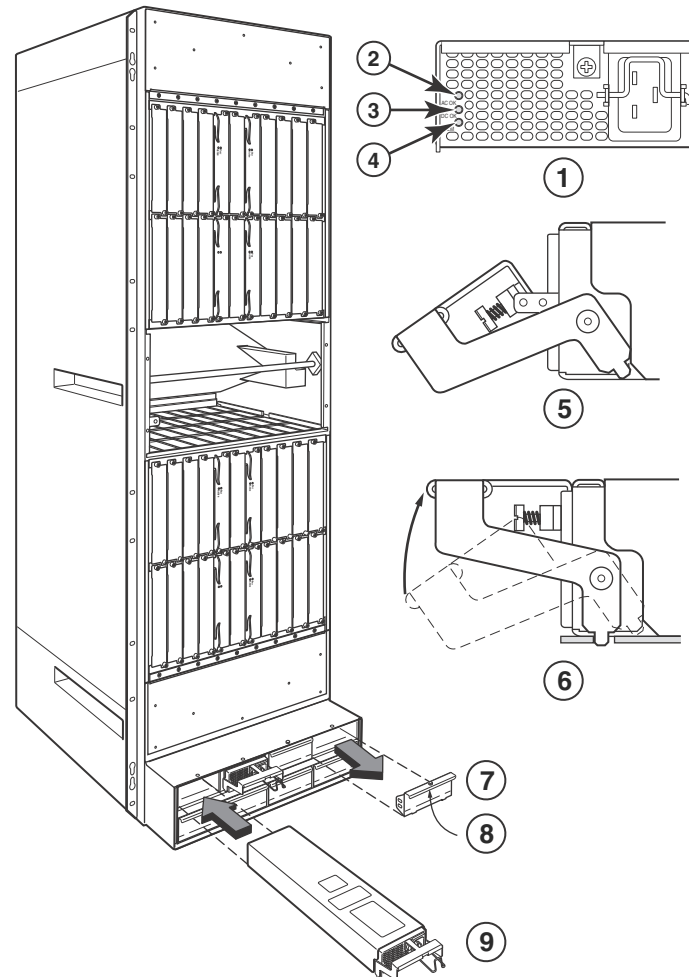

- |   |                         |   |                                |
|---|-------------------------|---|--------------------------------|
| 1 | Power supply indicators | 6 | Latch handle locked            |
| 2 | AC OK                   | 7 | Power supply blank cover       |
| 3 | DC OK                   | 8 | Pull down on plunger to remove |
| 4 | ALM                     | 9 | Power supply                   |
| 5 | Latch handle open       |   |                                |



### CAUTION

Carefully follow the mechanical guides on each side of the power supply slot and make sure the power supply is properly inserted in the guides. Never insert the power supply upside down.

4. Install a blank power supply faceplate into each slot that is empty after all of the power supplies have been installed.
5. After the power supply is fully inserted, push the power supply front panel toward the back of the chassis. This action causes the power supply connector to seat into the backplane connector.

6. Gently pull the release latch on the power supply front panel upward and toward the top of the power supply front panel. This action locks the power supply in place.
7. For information about connecting power to the chassis, refer to [“Connecting AC power to a BigIron RX-32 chassis”](#) on page 77.
8. For information about powering on the system, refer to [“Powering-on the power source”](#) on page 79.

## Connecting AC power to a BigIron RX-32 chassis

AC power is supplied through an AC power cord that is installed in the front of each power supply in the BigIron RX-32 chassis.

1. At the front of the BigIron RX-32 chassis, locate the power receptacle on the front panel of each power supply that has been installed. Refer to [Figure 55](#).
2. Lift the cord retainer and connect a Brocade-supplied AC power cord to the power supply.
3. Snap the cord retainer over the power plug to hold it in place.

**FIGURE 55** BigIron RX-32 power supply receptacle and cord retainer

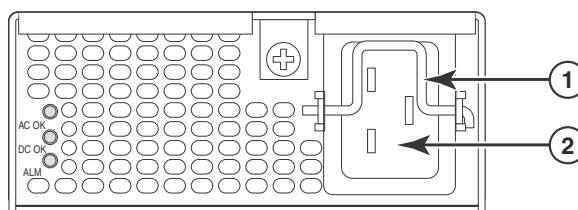

1 Cord retainer

2 Power receptacle

## Final steps

You should complete the final step in the order in which they are listed:

- [“Attaching a management station”](#)
- [“Powering-on the power source”](#)
- [“Verifying proper operation”](#)

## Attaching a management station

You can manage the BigIron RX Series system in the following ways:

- You can connect a PC or terminal to the management module’s serial (Console) port for a direct connection. From this interface, you can configure the 10BaseT/100BaseTX/1000BaseTX Ethernet (management) port with an IP address and either Telnet or SSH. This enables you to manage the device through the 10BaseT/100BaseTX/1000BaseTX Ethernet (management) port using either Telnet or SSH.

## 2 Attaching a management station

- You can connect the BigIron RX Series switch to your existing management network and manage the switch, along with other network devices, from a management station. To do this, you must connect the management module's 10BaseT/100BaseTX/1000BaseTX Ethernet (management) port to an Ethernet network.

---

### NOTE

The existing management network into which you can connect the 10/100 Ethernet port must be separate and isolated from the network over which user packets are switched and routed. For information about the management port's functionality, refer to ["Understanding how the management port functions"](#) on page 105.

---

For information about connecting a PC or terminal to the management module's Console port or management port, refer to ["Attaching a PC or terminal to the Console port or Ethernet port"](#) on page 78. For information about connecting a management port to a network, refer to ["Attaching the management module's Ethernet Port to a network"](#) on page 79.

## Attaching a PC or terminal to the Console port or Ethernet port

The management module's Console port (which has a male DB-9 serial connector), and 10BaseT/100Base TX Ethernet port (which has an RJ-45 UTP connector) allow you to attach a PC or terminal. From the Console port, you can access the BigIron RX Series switch's CLI directly from the PC or terminal or through a Telnet connection to the PC or terminal. From the Ethernet port, you can access the BigIron RX Series switch's CLI or Web management interface directly from the PC or terminal or through a Telnet connection to the PC or terminal.

Before performing this task, you need the following items:

- PC running a terminal emulation application or a terminal.
- If connecting the PC or terminal to the Console port, a straight-through EIA or TIA DB-9 serial cable with one end terminated in a female DB-9 connector and the other end terminated in a male or female DB-9 or DB-25 connector, depending on the specifications of your PC or terminal. You can order the serial cable separately from Brocade or build your own cable. If you prefer to build your own, refer to the pinout information in ["Console port pin assignments"](#) on page 205.
- If connecting the PC or terminal to the Ethernet port, a Category 5 UTP crossover cable, which you must supply. For information about the management port pin assignments, refer to ["Management port pin assignments"](#) on page 206.

Follow the steps given below to attach a PC or terminal to the Console port or Ethernet port.

1. Connect a PC or terminal to the Console port or Ethernet port using the appropriate cable.
2. Open the terminal emulation program, and set the session parameters as follows:
  - Baud: 9600 bps
  - Data bits: 8
  - Parity: None
  - Stop bits: 1
  - Flow control: None

## Attaching the management module's Ethernet Port to a network

The management module's 10BaseT/100BaseTX/1000BaseTX Ethernet (management) port (RJ-45 UTP connector) allows you to connect the management port to a network. A management station in your existing management network can then access a BigIron RX Series switch using the IronView Network Manager.

To attach the management module's Ethernet port to a network, you need a Category 5 UTP straight-through cable (not supplied by Brocade). Connect one end of the straight-through cable to the management port and the other end to the network.

## Powering-on the power source

After you complete the hardware installation, you can power-on your power source.

1. Verify that all modules and power supplies are fully and properly installed and no module slots are uncovered.



### CAUTION

**If you do not install a module in a slot, you must keep the slot blank in place. If you run the chassis with an uncovered slot, the system may overheat.**

2. If you are supplying a DC power source to a BigIron RX Series chassis, attach the power cables to the DC power supply as described in the appropriate section:
  - [“Connecting DC power to a BigIron RX-4 chassis”](#) on page 36
  - [“Connecting DC power to a BigIron RX-8 chassis”](#) on page 46
  - [“Connecting DC power to a BigIron RX-16 chassis”](#) on page 56Connect the other end of the cables to the DC power source. Repeat this step for each installed DC power supply. Then switch on the power source.
3. If your power source is AC, attach one end of a Brocade-supplied AC power cord to the AC power supply as described in the appropriate section:
  - [“Connecting AC power to a BigIron RX-4 chassis”](#) on page 36
  - [“Connecting AC power to a BigIron RX-8 chassis”](#) on page 45
  - [“Connecting AC power to a BigIron RX-16 chassis”](#) on page 55
  - [“Connecting AC power to a BigIron RX-32 chassis”](#) on page 77

## 2 Verifying proper operation

Insert the other end into a 115V or 120V wall outlet. Repeat this step for each installed AC power supply.



### **DANGER**

*If the installation requires a different power cord than the one supplied with the device, make sure you use a power cord displaying the mark of the safety agency that defines the regulations for power cords in your country. The mark is your assurance that the power cord can be used safely with the device.*



### **CAUTION**

If the wall outlet is not rated 115/120V and 20A, you must have an electrician rewire the outlet and power source. Make sure you obtain a power cord displaying the mark of the safety agency that defines the regulations for power cords in your country. The mark is your assurance that the power cord can be used safely with the device.

---

### **NOTE**

The BigIron RX Series switch is designed to provide uninterrupted service even when you insert or remove the management modules and the interface modules. Therefore, the system does not have a separate on/off power switch. To turn the system off, simply unplug the power cords.

---

### **NOTE**

The wall outlet should be installed near the equipment and should be easily accessible.

4. Verify that the BigIron RX Series switch has initialized successfully. For information, refer to [“Verifying proper operation”](#) on page 80.

## Verifying proper operation

To verify the proper operation of the BigIron RX Series chassis after power on, you can do the following:

- Observe the LEDs
- Display the status of the modules using the CLI

### Observing the LEDs

After a BigIron RX Series chassis powers on, you can observe its LEDs to verify that it initialized successfully. [Table 13](#) outlines the LEDs, the desired state of each LED, possible abnormal states of each LED, and what to do if an LED indicates an abnormal state.



**TABLE 13** Desired and abnormal LED states after system power on

LED	Desired state	Meaning	Abnormal state	Meaning or action
<b>Management module</b>				
Active	The Active LED on one of the installed management modules should be on.	The module is functioning as the active management module.	Off	Neither of the management modules is managing the switch fabric and interface modules. A problem could have occurred during initialization. Check your attached PC or terminal for possible error messages.
Pwr	On	The module is receiving power.	Off	The module is not receiving power. You can do the following: <ul style="list-style-type: none"> <li>• Make certain that the module is installed properly. For more information, refer to <a href="#">“Installing BigIron RX-4 modules”</a> on page 33, <a href="#">“Installing BigIron RX-8 modules”</a> on page 42, <a href="#">“Installing BigIron RX-16 modules”</a> on page 52, or <a href="#">“Installing BigIron RX-32 modules”</a> on page 62.</li> <li>• If using AC power supplies, see the entry for the AC power supply LED in this table for more information.</li> </ul>
10/100/1000 Ethernet Port	On (Green)	A link is established with the remote port.	Off	A link is not established with the remote port. You can do the following: <ul style="list-style-type: none"> <li>• Verify that the connection to the other device has been properly made. Also, make certain that the other device is powered on and operating correctly.</li> <li>• Try using a different cable.</li> </ul>
10/100/1000 Ethernet Port	On or blinking (Yellow)	The port is transmitting and receiving packets.	Off for an extended period	The port is not transmitting or receiving packets. You can check the other 10/100/1000 Ethernet port LED to make sure a link is established with the remote port. If not, take the actions described in the Meaning or Action column for the other 10/100/1000 Ethernet port LED.

## 2 Verifying proper operation

**TABLE 13** Desired and abnormal LED states after system power on (Continued)

LED	Desired state	Meaning	Abnormal state	Meaning or action
<b>Interface module</b>				
Pwr	On	The module is receiving power.	Off	<p>The module is not receiving power. You can do the following:</p> <ul style="list-style-type: none"> <li>• Make certain that the module is installed properly. For more information, refer to <a href="#">“Installing BigIron RX-4 modules”</a> on page 33, <a href="#">“Installing BigIron RX-8 modules”</a> on page 42, <a href="#">“Installing BigIron RX-16 modules”</a> on page 52, or <a href="#">“Installing BigIron RX-32 modules”</a> on page 62.</li> <li>• The module may not be receiving enough power. Brocade recommends installing power supplies in a fully redundant configuration as described in <a href="#">“Installing power supplies in a BigIron RX-4 chassis”</a> on page 35, <a href="#">“Installing power supplies in the BigIron RX-8 chassis”</a> on page 44, <a href="#">“Installing power supplies in a BigIron RX-16 chassis”</a> on page 54, or <a href="#">“Installing power supplies in a BigIron RX-32 chassis”</a> on page 75.</li> <li>• Check the Pwr LED on the management module. If it is on, this module may be holding the power from the interface module.</li> <li>• Enter the <b>show chassis</b> command at any level of the CLI to determine if the management module recognizes the presence of all power sources.</li> <li>• If using AC power supplies, see the entry for the AC power supply LED in this table for more information.</li> </ul>
Mgmt Act	During initialization: steady blinking. After initialization: occasional blinking.	The active management module’s processor and the interface module’s processor are communicating.	Off for an extended period.	The interface module may be in interactive mode. Check the status of the module by entering the <b>show module</b> command at any CLI prompt.

**TABLE 13** Desired and abnormal LED states after system power on (Continued)

LED	Desired state	Meaning	Abnormal state	Meaning or action
Link	On	A link is established with the remote port.	Off	At this stage of the installation, you have not yet cabled the interface module ports, so this LED will be off. After cabling this port, if this LED is off, a link is not established with the remote port. For more information, refer to <a href="#">Table 16</a> on page 109.
Active	On or blinking	The port is transmitting and receiving user packets.	Off for an extended period.	At this stage of the installation, you have not yet cabled the interface module ports, so this LED will be off. After cabling this port, if this LED is off, the port is not transmitting or receiving user packets. For information about action you can take to troubleshoot the problem, refer to <a href="#">Table 16</a> on page 109.
<b>Switch fabric module</b>				
Pwr	On	The module is receiving power.	Off	The module is not receiving power. You can do the following: <ul style="list-style-type: none"> <li>• If using AC power supplies, see the entry for the AC power supply LED in this table for more information.</li> </ul>
Active	On	The switch fabric module is active and ready to switch user packets.	Off for an extended period.	The switch fabric module is not active and user packets are not being switched from one interface module to another. You must replace the switch fabric module. For information about performing this task, refer to <a href="#">“Replacing a switch fabric module”</a> on page 143.
<b>Power supplies AC</b>				
AC OK	Green (steady)	The power supply is receiving AC power from an AC power source.	Off	The power supply is not receiving power from an AC power source. You can do the following: <ul style="list-style-type: none"> <li>• Make sure that the power supply cord is connected securely to the wall outlet and the power supply.</li> <li>• Make sure that the wall outlet is rated for 115/120V and 20A. If it is not, obtain a cable that is compatibly rated for the outlet.</li> <li>• Make sure that the wall outlet has power.</li> </ul>

## 2 Verifying proper operation

**TABLE 13** Desired and abnormal LED states after system power on (Continued)

LED	Desired state	Meaning	Abnormal state	Meaning or action
DC OK	Green (steady)	The power supply is providing DC power to the BigIron RX Series chassis.	Off	The power supply is not supplying power to the chassis. If the AC OK LED is lit Green, then there is a problem with the power supply and it must be replaced.
ALM	ALM	The power supply is in normal operating condition.	Amber	The power supply is malfunctioning.
<b>Power supplies DC</b>				
DC IN	Green (steady)	The power supply is receiving DC power from a DC power source.	Off	The power supply is not receiving power from a DC power source You can do the following: <ul style="list-style-type: none"> <li>• Make sure that the power supply cables are connected securely to the power source and the power supply.</li> <li>• Make sure that the DC power source is 48 VDC @ 30 A (Operating voltage range is 40-60VDC).</li> <li>• Make sure that the power source has power.</li> </ul>
DC OUT	Green (steady)	The power supply is providing DC power to the BigIron RX Series chassis.	Off	The power supply is not supplying power to the chassis. If the DC IN LED is lit Green, then there is a problem with the power supply and it must be replaced.
ALM	Off	The power supply is in normal operating condition.	Amber	The power supply is malfunctioning.

**TABLE 13** Desired and abnormal LED states after system power on (Continued)

LED	Desired state	Meaning	Abnormal state	Meaning or action
<b>Fan control module (two LEDs on rear panel of chassis)</b>				
Unlabeled	Green (steady)	The fans are working and responding to controls from the fan control module.	Off or amber	<p>The fans are not receiving power (off), or the fans are not working and not responding to controls from the fan control module (amber). You can do the following:</p> <ul style="list-style-type: none"> <li>If the LED is off, check the power LED on the other modules to make sure they are receiving power.</li> </ul> <p>If using a DC power source, check your power source for problems.</p> <p>If using AC power supplies, take the actions described in the Meaning or Action column for the AC power supply LED. If these actions do not resolve the problem, check the LED on each power supply or enter the <b>show chassis</b> command at any CLI prompt to determine if a power supply has failed. If a power supply has failed, you need to replace it. For more information, refer to <a href="#">“Replacing a power supply”</a> on page 147.</p> <ul style="list-style-type: none"> <li>If the LED is amber, you need to replace the fan module. For information about performing these tasks, see.</li> </ul>

If a problem persists after taking action described in this table, contact Brocade for technical support.

## Displaying the module status

After you have attached a PC or terminal to the management module's Console port or Ethernet port and the BigIron RX Series switch has initialized successfully, press Enter to display the following CLI prompt in the terminal emulation window:

```
BigIron RX>
```

## 2 Verifying proper operation

If you do not see this prompt, do the following.

1. Make sure the cable is securely connected to your PC or terminal and the Console port or Ethernet port.
2. Check the settings in your terminal emulation program. In addition to the session settings listed in “Attaching a PC or terminal to the Console port or Ethernet port” on page 78, make sure the terminal emulation session is running on the same serial port you attached to the Console port.

If you see this prompt (BigIron RX>), you are now connected to the system and can display the status of the modules using the CLI. Enter the following command at any CLI level:

```
BigIron RX# show module
      Module                               Status      Ports  Starting MAC
M1 (upper): BigIron RX Mgmt Module        Active
M2 (lower):
F0: BigIron RX Switch Fabric Module       Active
S1:
S2:
S3:
S4: BigIron RX 4-Port 10Gig Module        CARD_STATE_UP  4  000c.db80.0000
S5: BigIron RX 4-Port 10Gig Module        CARD_STATE_UP  4  000c.db80.0000
S6: BigIron RX 4-Port 10Gig Module        CARD_STATE_UP  4  000c.db80.0000
S7:
S8:
```

**Syntax:** show module

The Status column shows the module status. A management module can have one of the following statuses:

- ACTIVE – The module is currently the active management module.
- STANDBY – The module is currently the standby management module.
- COMING UP – The module is coming up as the standby module. This status occurs if the standby management module becomes the active module, which is called a switchover.

The switch fabric module can have one of the following statuses:

- ACTIVE – The module is up and running.
- BAD – The management module cannot initialize the switch fabric module.

An interface module can have one of the following statuses:

- CARD\_STATE\_INIT – The system detects the module but the module is not up and running yet.
- CARD\_STATE\_BOOT – The module is booting.
- CARD\_STATE\_INTERACTIVE – The module is booting from interactive mode.
- CARD\_STATE\_LP\_SYNC – The module’s IronWare images are synchronized between the management module and interface module.
- CARD\_STATE\_SYNC – The system is currently synchronizing the module’s IronWare images between the management module and interface module.
- CARD\_STATE\_SOFTWARE\_LOADED – The module has loaded its IronWare image.
- CARD\_STATE\_POWER\_OFF – The module does not have power.
- CARD\_STATE\_UP – The module is up and operating normally.

- `CARD_STATE_FAILED` – The management module was unable to bring up an interface module properly. If you observe this status, make certain that the interface module is installed properly. For more information, refer to [“Installing BigIron RX-4 modules”](#) on page 33, [“Installing BigIron RX-8 modules”](#) on page 42, [“Installing BigIron RX-16 modules”](#) on page 52, or [“Installing BigIron RX-32 modules”](#) on page 62.
- `CARD_DOWN_REASON_<explanation>` – The module is in a nonfunctional state. This status appears with an explanation for why the module is down, for example, `"CARD_DOWN_REASON_BOOT_FAILED."` If the explanation does not help you resolve the problem, you can contact Brocade technical support and provide the explanation included with this status.

## 2 Verifying proper operation



# Using the Brocade Structured Cabling Components

## In this chapter

- [Cable Cinch overview](#) ..... 89
- [mRJ-21 procedures](#) ..... 90
- [RJ-45 procedures](#) ..... 94

## Cable Cinch overview

Use the following guidelines when using the Brocade Cable Cinch Clips with mRJ-21 or RJ-45 cables. The following sections will provide detailed instructions:

- “[mRJ-21 procedures](#)” on page 90
- “[RJ-45 procedures](#)” on page 94

Position the cable cinch with the open end to the left (no slot) as shown in [Figure 56](#).

**FIGURE 56** Cable Cinch overview

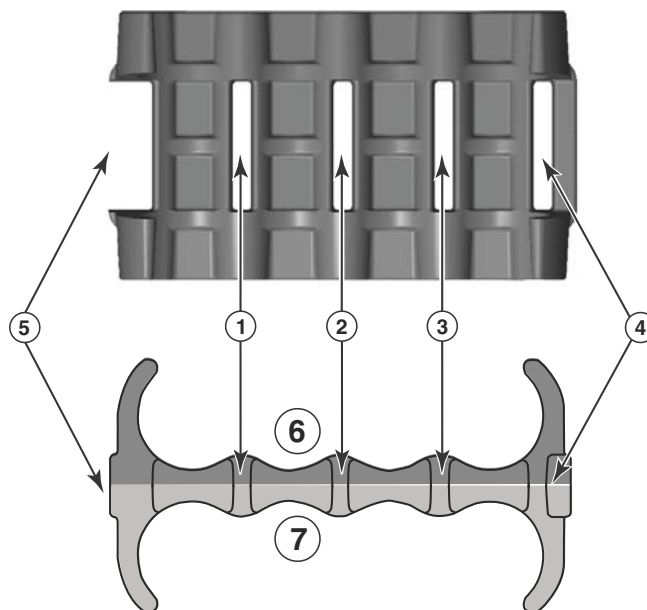

- |   |        |   |          |
|---|--------|---|----------|
| 1 | Slot 1 | 5 | Open end |
| 2 | Slot 2 | 6 | Rear     |
| 3 | Slot 3 | 7 | Front    |
| 4 | Slot 4 |   |          |

## mRJ-21 procedures

The following procedure demonstrates securing up to eight RJ-21 cables into the Cable Cinch. When securing fewer than the maximum cables, follow the procedure to secure the desired number of cables and simply wrap the remaining Velcro strap around the Cable Cinch. Use the additional slots in the clip to secure groups of cables as required.

### Cable Cinch with two mRJ-21 cables

To secure two mRJ-21 cables, place the Velcro strap through slot one and use the front and rear left recesses as shown in [Figure 57](#).

**FIGURE 57** Two mRJ-21 cables

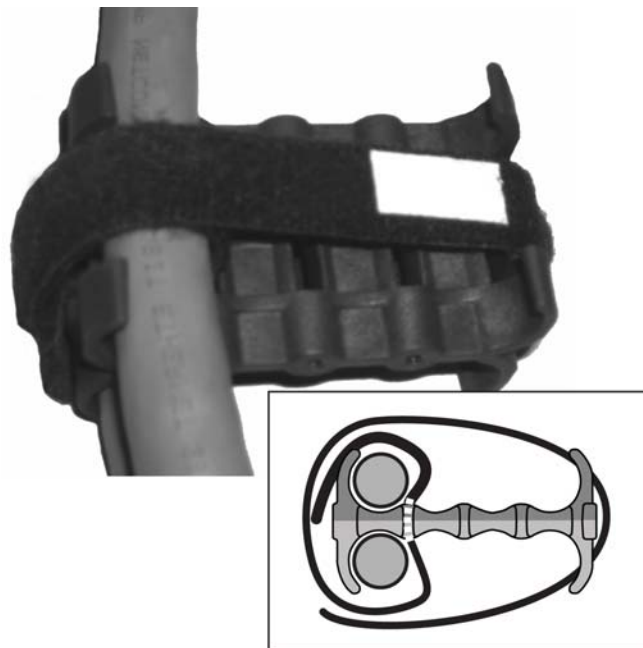

## Cable Cinch with three mRJ-21 cables

Three mRJ-21 cables may be secured as shown in [Figure 58](#).

**FIGURE 58** Three mRJ-21 cables

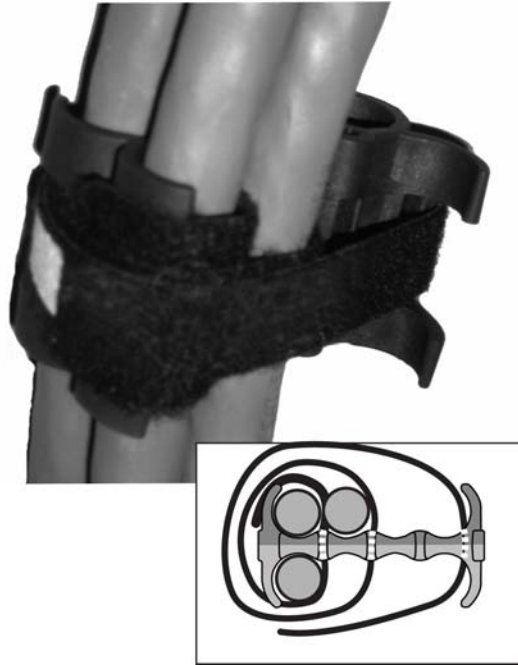

## Cable Cinch with four mRJ-21 cables

Four mRJ-21 cables may be secured as shown in [Figure 59](#).

**FIGURE 59** Four mRJ-21 cables

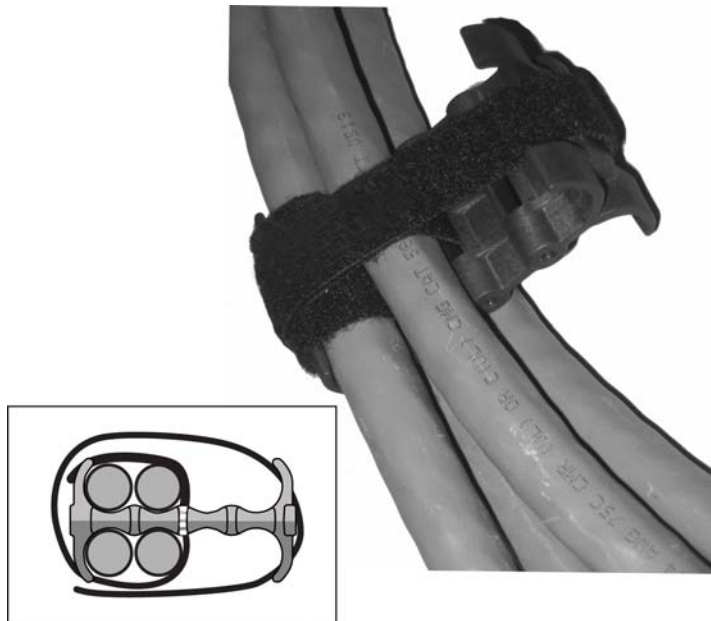

### Cable Cinch with five mRJ-21 cables

Five mRJ-21 cables may be secured as shown in [Figure 60](#).

FIGURE 60 Five mRJ-21 cables

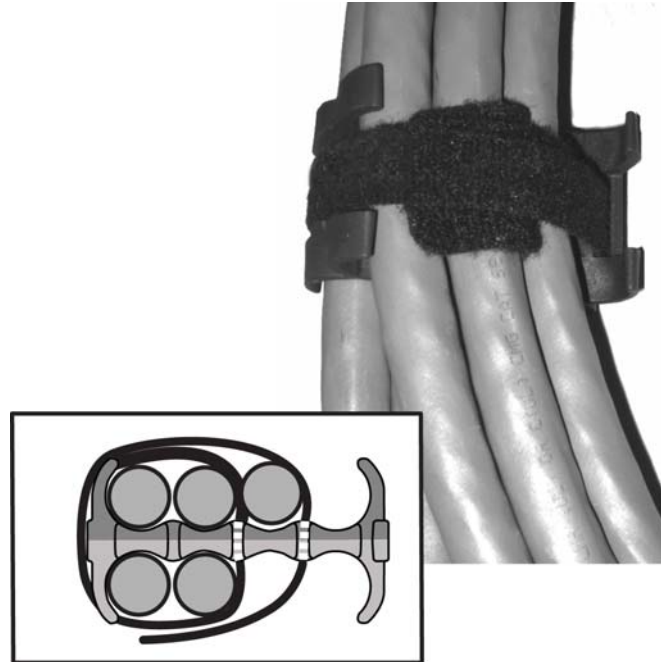

### Cable Cinch with six mRJ-21 cables

Six mRJ-21 cables may be secured as shown in [Figure 61](#).

FIGURE 61 Six mRJ-21 cables

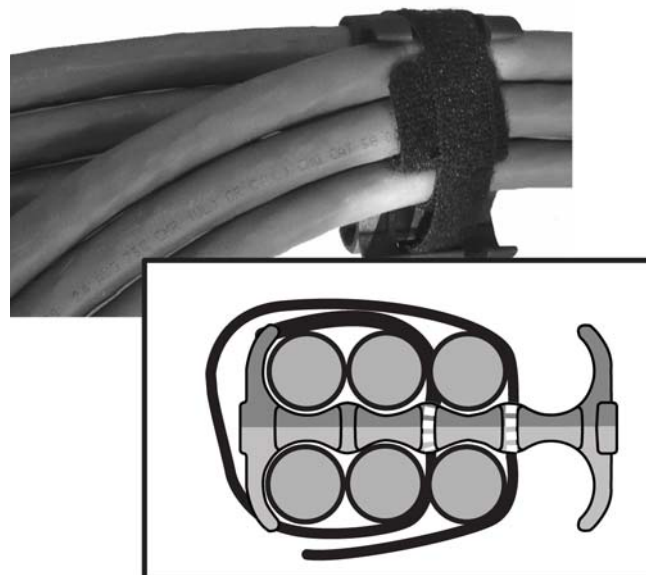

## Cable Cinch with seven mRJ-21 cables

Seven mRJ-21 cables may be secured as shown in [Figure 62](#).

FIGURE 62 Seven mRJ-21 cables

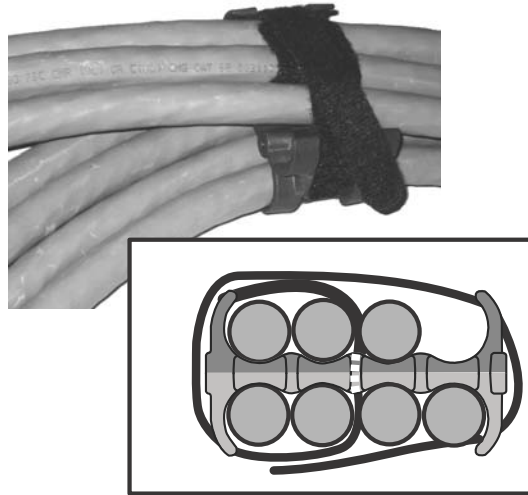

## Cable Cinch with eight mRJ-21 cables

Eight mRJ-21 cables may be secured as shown in [Figure 63](#).

FIGURE 63 Eight mRJ-21 cables

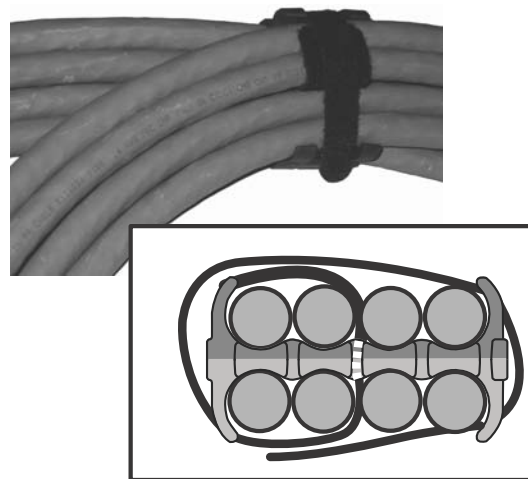

## RJ-45 procedures

Use the following guidelines when using the cable cinch clips with RJ-45 cables.

### Cable Cinch with one group of RJ-45 cables

RJ-45 cables may be secured in groups of six. To secure up to six RJ-45 cables in one group, place the Velcro strap through slot one and use the front left recesses as shown in [Figure 64](#).

FIGURE 64 One group of RJ-45 cables

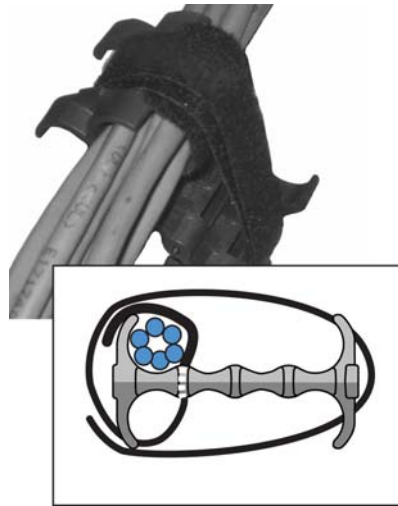

### Cable Cinch with two groups of RJ-45 cables

12 RJ-45 cables, in two groups, may be secured as shown in [Figure 65](#).

FIGURE 65 12 RJ-45 cables in two groups

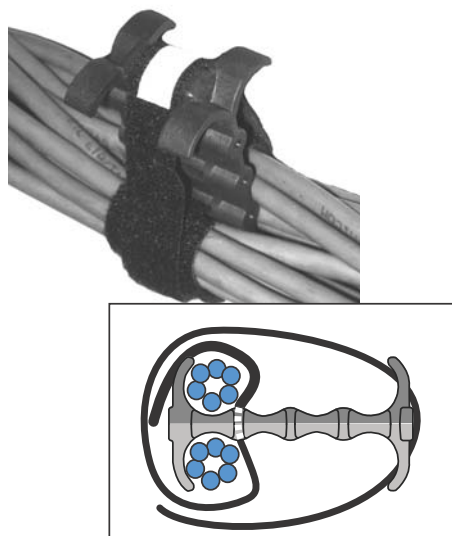

### Cable Cinch with three groups of RJ-45 cables

18 RJ-45 cables, in three groups, may be secured as shown in [Figure 66](#).

FIGURE 66 18 RJ-45 cables in three groups

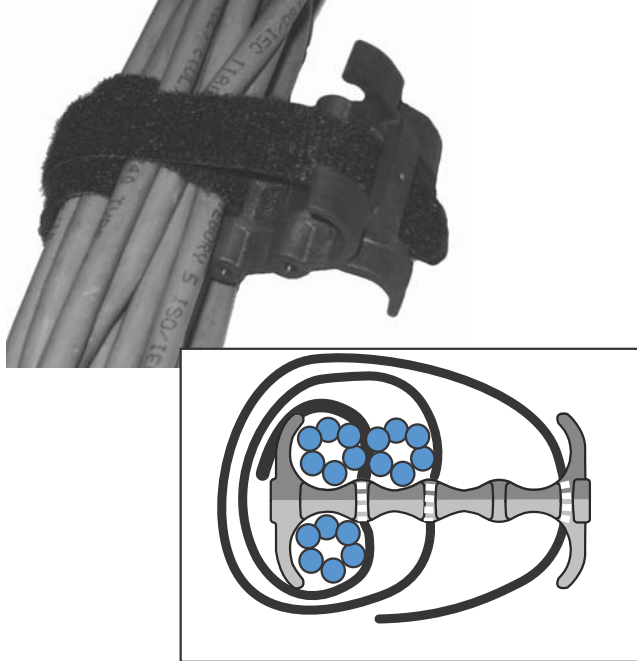

### Cable Cinch with four groups of RJ-45 cables

24 RJ-45 cables, in four groups, may be secured as shown in [Figure 67](#).

FIGURE 67 24 RJ-45 cables in four groups



### Cable Cinch with five groups of RJ-45 cables

30 RJ-45 cables, in five groups, may be secured as shown in [Figure 68](#).

FIGURE 68 30 RJ-45 cables in five groups

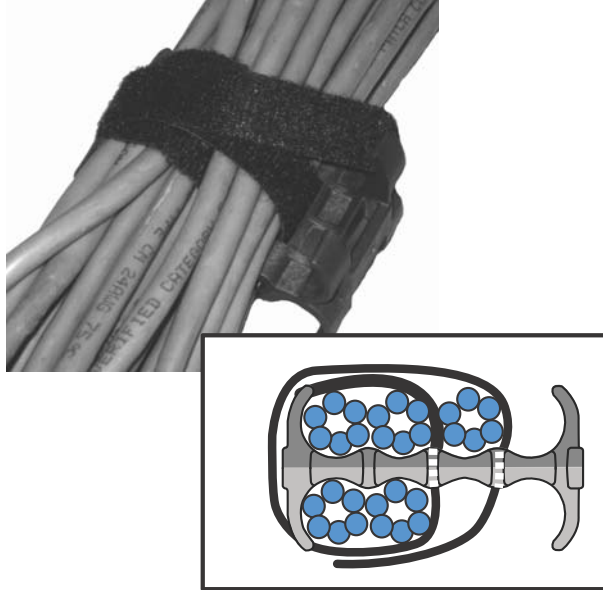

### Cable Cinch with six groups of RJ-45 cables

36 RJ-45 cables, in six groups, may be secured as shown in [Figure 69](#).

FIGURE 69 36 RJ-45 cables in six groups

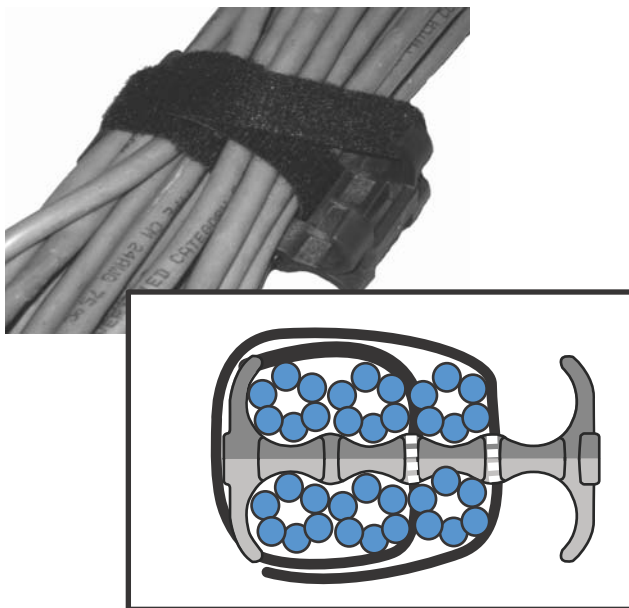



## Cable Cinch with seven groups of RJ-45 cables

42 RJ-45 cables, in seven groups, may be secured as shown in [Figure 70](#).

**FIGURE 70** 42 RJ-45 cables in seven groups

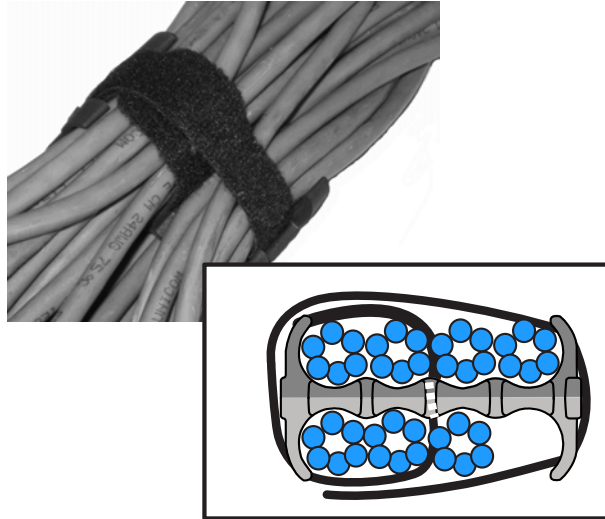

## Cable Cinch with eight groups of RJ-45 cables

48 RJ-45 cables, in eight groups, may be secured as shown in [Figure 71](#).

**FIGURE 71** 48 RJ-45 cables in eight groups

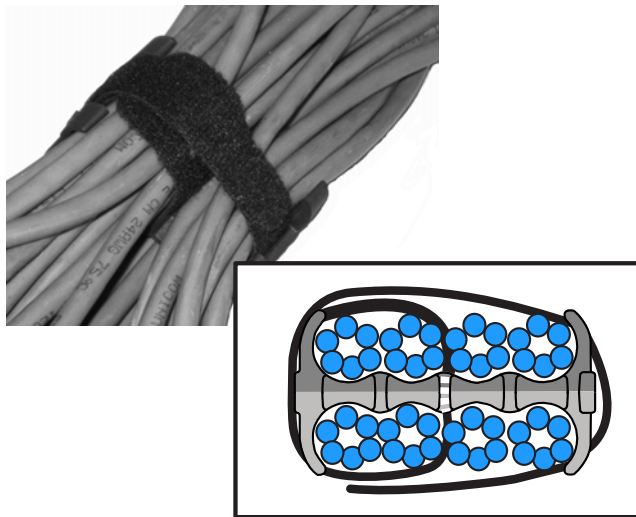

### 3 RJ-45 procedures

# Connecting a BigIron RX Series Switch to a Network Device **4**

---

## In this chapter

- Assigning passwords ..... 99
- Configuring IP addresses ..... 102
- Understanding how the management port functions ..... 105
- Connecting a BigIron RX Series switch ..... 105
- Testing network connectivity ..... 110

## Assigning passwords



### **DANGER**

*The procedures in this manual are for qualified service personnel.*

When you create an enable and a user password, you must enter a minimum of eight characters containing the following combinations:

- At least two upper case characters
- At least two lower case characters
- At least two numeric characters
- At least two special characters

When you create a password, the characters you type are masked.

For example, to create a password for the **enable** login:

```
BigIron RX(config)#enable password TesT12$!
```

**Syntax:** enable password <password>

To assign a password for a user account:

```
BigIron RX(config)#username sandy password [Enter]
Enter password: *****
```

**Syntax:** username <name> password [Enter]

Press the Enter key for [Enter]. Enter a password such as TesT12\$! that contains the required character combination.

### **NOTE**

When you upgrade to Release 02.2.01 or later, the old passwords are still valid; however, users must change their passwords to follow the new format to take advantage of this password enhancement.

There are no new CLI commands for this feature.

### *Login lockout*

The CLI provides up to three login attempts. If a user fails to login after three attempts, that user is locked out (disabled). To re-enable the user, do one of the following:

- Rebooting the BigIron RX to re-enable all disabled users.
- Enable the user by entering the following command:

```
BigIron RX(config)#username sandy enable [Enter]
```

For example:

```
SSH@BigIron RX(config)#user sandy enable
SSH@BigIron RX(config)#show user
Username Password Encrypt Priv Status Expire Time
=====
sandy $1$Gz...uX/$wQ44fVGtsqbKwKQknzAZ6. enabled 0 enabled 90 days
```

**Syntax:** username <name> enable [Enter]

### *Password history*

The CLI will keep the last 15 passwords used by the user. A user will be prevented from changing their password to one that has already been used. This is for security purposes so that users do not use the same passwords multiple times.

### *Setting passwords to expire*

You can set a user password to expire. Once a password expires, the administrator must assign a new password to the user. To configure a user password to expire, enter the following:

```
BigIron RX(config)#username sandy expires 20
```

**Syntax:** username <name> expires <days>

Enter 1 – 365 for number of days. The default is 90 days.

For example:

```
SSH@BigIron RX(config)#username sandy expires 20
SSH@BigIron RX(config)#show user
Username Password Encrypt Priv Status Expire Time
=====
===
sandy $1$Gz...uX/$wQ44fVGtsqbKwKQknzAZ6. enabled 0 enabled 20 days
```

The CLI contains the following access levels:

- User EXEC – The level you enter when you first start a CLI session. At this level, you can view some system information but you cannot configure system or port parameters.

- Privileged EXEC – This level is also called the Enable level and can be secured by a password. You can perform tasks such as manage files on the management module’s flash memory or a PCMCIA flash card in the management module’s slots 1 or 2, save the system configuration to flash memory, and clear caches at this level.
- CONFIG – The configuration level. This level lets you configure the system’s IP address and configure routing features. To access the CONFIG mode, you must already be logged into the Privileged level of the EXEC mode.

**NOTE**

You cannot assign a password using the Web management interface. You can assign passwords using the IronView Network Manager if an Enable password for a Super User is already configured on the device.

You can set the following levels of Enable passwords:

- Super User – Allows complete read-and-write access to the system. This is generally for system administrators and is the only password level that allows you to configure passwords.

**NOTE**

You must set a super user password before you can set other types of passwords.

- Port Configuration – Allows read-and-write access for specific ports but not for global (system-wide) parameters.
- Read Only – Allows access to the Privileged EXEC mode and CONFIG mode but only with read access.

To set passwords:

1. At the opening CLI prompt, enter the following command to change to the Privileged level of the EXEC mode:

```
BigIron RX> enable
BigIron RX#
```

2. Access the CONFIG level of the CLI by entering the following command:

```
BigIron RX# configure terminal
BigIron RX(config)#
```

3. Enter the following command to set the super-user password:

```
BigIron RX(config)# enable super-user-password <text>
```

**NOTE**

You must set the super-user password before you can set other types of passwords.

4. Enter the following commands to set the port configuration and read-only passwords:

```
BigIron RX(config)# enable port-config-password <text>
BigIron RX(config)# enable read-only-password <text>
```

**Syntax:** enable super-user-password | read-only-password | port-config-password <text>

Passwords can be up to 48 characters long.

## Configuring IP addresses

The BigIron RX Series switches implement separate data and control planes. This architecture affects how you assign IP addresses. [Table 14](#) outlines the interfaces to which you can assign IP addresses.

In this table, “in band” refers to an interface over which user packets are routed, while “out of band” refers to an interface over which control packets related to system management are forwarded.

**TABLE 14** Assigning IP addresses

Interface	Associated physical port	Out of band or in band
Management interface	Ethernet 10/100/1000 port on active or redundant management module	Out of band
Any interface over which user packets are routed	Any interface module port	In band
Any virtual interface over which user packets are routed	Any interface port	In band
Loopback interface	-	In band

This section describes the following:

- BigIron RX Series support of sub-net masks
- How to assign an IP address to a management interface
- How to assign an IP address to an interface or virtual interface over which user packets are routed

### Support of sub-net masks

The BigIron RX Series switch supports both classical IP network masks (Class A, B, and C sub-net masks, and so on) and Classless Interdomain Routing (CIDR) network prefix masks.

- To enter a classical network mask, enter the mask in IP address format. For example, enter “209.157.22.99 255.255.255.0” for an IP address with a Class-C sub-net mask.
- To enter a prefix number for a network mask, enter a forward slash ( / ) and the number of bits in the mask immediately after the IP address. For example, enter “209.157.22.99/24” for an IP address that has a network mask with 24 significant (“mask”) bits.

### Assigning an IP address to a management interface

Instead of assigning a global IP address to the BigIron RX Series switch for system management purposes, you now assign an IP address to the management interface. The IP address is assigned to the active management module port. If the active management module becomes unavailable and the redundant module becomes the active module, the IP address is assigned to the new active management module port.

For example, to assign the IP address 10.0.1.1 to the management interface, do the following:

1. At the opening CLI prompt, enter enable.

```
BigIron RX> enable
```

2. Enter the following command at the Privileged EXEC level prompt (for example, BigIron RX#), then press Enter. This command erases the factory test configuration if still present:

```
BigIron RX# erase startup-config
```



### CAUTION

Use the `erase startup-config` command only for new systems. If you enter this command on a system you have already configured, the command erases the configuration. If you accidentally erase the configuration on a configured system, enter the write memory command to save the running configuration to the startup-config file.

3. Access the configuration level of the CLI by entering the following command:

```
BigIron RX# configure terminal          Privileged EXEC Level
BigIron RX(config)#                    Global CONFIG Level
```

4. Configure the IP address and mask for the management interface by entering the following commands:

```
BigIron RX(config)# interface management 1
BigIron RX(config-if-mgmt-1)# ip address 10.0.1.1 255.255.255.0
```

**Syntax:** enable [<password>]

**Syntax:** configure terminal

**Syntax:** interface management 1

**Syntax:** [no] ip address <ip-addr> <ip-mask>

**Syntax:** or

**Syntax:** [no] ip address <ip-addr>/<mask-bits>

## Assigning an IP address to an interface, virtual interface, or loopback

As you have done with other Brocade devices, you must assign an IP address to each interface and virtual interface over which user packets are routed. You can also assign an IP address to a loopback interface, which is generally used for testing and diagnostic purposes.

You must use the serial connection to assign the first IP address. For subsequent addresses, you also can use the CLI through Telnet or the Web management interface. You can use IronView Network Manager Network Manager to assign IP addresses to virtual routing interfaces only.

By default, you can configure up to 24 IP interfaces on each interface, virtual interface, and loopback interface.

## 4 Configuring IP addresses

For example, to assign the IP address 192.22.3.44 and sub-net mask 255.255.255.0 to Ethernet interface 1/1, do the following.

1. At the opening CLI prompt, enter **enable**.

```
BigIron RX> enable
```

2. Enter the following command at the Privileged EXEC level prompt, then press Enter. This command erases the factory test configuration if still present:

```
BigIron RX# erase startup-config
```



### CAUTION

Use the `erase startup-config` command only for new systems. If you enter this command on a system you have already configured, the command erases the configuration. If you accidentally erase the configuration on a configured system, enter the write memory command to save the running configuration to the startup-config file.

3. Access the configuration level of the CLI by entering the following command:

```
BigIron RX# configure terminalPrivileged EXEC Level
BigIron RX(config)# Global CONFIG Level
```

4. Configure the IP address and sub-net mask for Ethernet interface 1/1 by entering the following commands:

```
BigIron RX(config)# interface ethernet 1/1
BigIron RX(config-if-e10000-1/1)# ip address 192.22.3.44 255.255.255.0
```

**Syntax:** `enable [<password>]`

**Syntax:** `configure terminal`

**Syntax:** `[no] ip address <ip-addr> <ip-mask> [secondary]`

**Syntax:** `or`

**Syntax:** `[no] ip address <ip-addr>/<mask-bits> [secondary]`

Use the **secondary** parameter if you have already configured an IP address within the same sub-net on the interface.

## Enabling and disabling the interfaces

By default, all BigIron RX Series interfaces are disabled. To enable an interface, you must enter the **enable** command at the appropriate interface configuration level of the CLI. For example, to enable the management interface, enter the **enable** command at the management interface configuration level of the CLI:

```
BigIron RX(config-if-mgmt-1)# enable
```

**Syntax:** `enable`

You can disable each of these interfaces using the **disable** command at the appropriate interface configuration level of the CLI. For example, to disable the management port, enter the **disable** command at the management interface configuration level of the CLI:

```
BigIron RX(config-if-mgmt-1)# disable
```



**Syntax:** disable

## Understanding how the management port functions

You must be aware of how the BigIron RX Series system's management port functions as described in the following:

- The management port allows you to configure, monitor, and manage the BigIron RX Series system only. As a result, this port has the same limited functionality as an IP host port.
- You cannot enable and run routing protocols on the management port.
- The management port supports static routes and directly connected routes, which are installed in the management module's routing table. However, these routes are not installed in the interface module's routing table. Therefore, the interface modules are not aware of the management port's static or directly connected routes.
- If you configure the redistribution of directly connected or static routes for a particular routing protocol, the routing protocol will redistribute directly connected or static routes associated with the interface module ports but not those associated with the management port.
- On a BigIron RX Series system running Layer 2 Switch code, the management port does not support a default gateway. However, if you configure a default gateway for the management port, the BigIron RX Series system will convert the default gateway into a static route.
- On a BigIron RX Series system running Layer 2 Switch code, the management port supports multiple static routes. However, you cannot configure multiple static routes to the same destination for a management port.

To display configuration information and statistics about the management port, you can enter the **show interface management 1** command at any CLI level.

## Connecting a BigIron RX Series switch

You can connect a BigIron RX Series switch to another 10 Gigabit Ethernet network device. The BigIron RX Series switch supports connections to other vendors' as well as Brocade devices.

The 10 Gigabit Ethernet interface module includes four ports, into which you can install fiber optic modules provided by Brocade. The SFP fiber optic modules provide an optical transceiver or a physical medium dependent (PMD) interface for fiber that can be used with the LAN physical layer (PHY).

[Table 15](#) outlines the fiber optic modules (PMDs) provided by Brocade, the link distance associated with each, the cabling needed to connect the BigIron RX Series switch to another network device, and the part number associated with the module.

**TABLE 15** Fiber optic modules and cabling

Fiber optic modules (PMD)	Distance	Fiber optic cabling	Brocade part number
Short wavelength	86 meters	50/125 micron multimode fiber (500 Mhz km)	10G-XFP-SR
850 nm serial	300 meters	50/125 micron multimode fiber (2000 Mhz km)	

## 4 Connecting a BigIron RX Series switch

**TABLE 15** Fiber optic modules and cabling (Continued)

Fiber optic modules (PMD)	Distance	Fiber optic cabling	Brocade part number
Long wavelength 1310 nm serial	10 km	9/125 micron single-mode fiber with LC connectors	10G-XFP-LR
Extra long wavelength 1550 nm serial	40 km	9/125 micron single-mode fiber with LC connectors	10G-XFP-ER

### NOTE

Cable installation and network configuration will affect overall transmission capability. The numbers provided above represent the accepted recommendations of the various standards. For network-specific recommendations, consult your local Brocade reseller or system engineer.

To connect a BigIron RX Series switch to another network device, you must do the following:

- Install the fiber optic modules
- Cable the fiber optic modules

The following sections provide information about performing these tasks as well as cleaning the fiber optic connectors and troubleshooting network connections.

## Installing a fiber optic module

You connect a BigIron RX Series switch to another network device using a fiber port, you must do the following:

- Install a fiber optic module (SFP transceiver for Gigabit Ethernet ports or SFP-MSA transceiver for 10-Gigabit Ethernet ports)



### DANGER

***All fiber optic interfaces use Class 1 Lasers.***

### NOTE

Refer to [“Installation precautions”](#) on page 25 for other hardware installation precautions.

Before installing a fiber optic module, have on hand an ESD wrist strap with a plug for connection to the ESD connector on the BigIron RX Series chassis.



### DANGER

***For safety reasons, the ESD wrist strap should contain a 1 meg ohm series resistor.***

To install a fiber optic module into an Ethernet port, do the following.

1. Put on the ESD wrist strap and ground yourself by inserting the plug into the ESD connector located in the upper right corner of the chassis front.
2. Remove the module from its protective packaging.
3. Remove the metal cover from the port on the interface module's control panel.

4. Gently insert the fiber optic module into the port until the module clicks into place. The fiber optic modules are keyed to prevent incorrect insertion.

## Cabling a fiber optic module

To cable a fiber optic module, do the following.

1. Remove the protective covering from the fiber optic port connectors and store the covering for future use.
2. Before cabling a fiber optic module, Brocade strongly recommends cleaning the cable connectors and the port connectors. For more information, refer to [“Cleaning fiber optic modules”](#) on page 108.
3. Gently insert the two cable connectors (a tab on each connector should face upward) into the port connectors until the tabs lock into place.

## Enhanced Digital Optical Monitoring

You can configure your BigIron RX Series switch to monitor XFPs and SFPs in the system either globally or by specified port. If monitoring is enabled, console messages, syslog messages, and SNMP traps are sent when XFP or SFP operating conditions warrant it.

Beginning with release 0 2.6.00, Digital Optical Monitoring will only support newly qualified 1Gigabyte optics. Digital Optical Monitoring for previous 1Gigabyte optics that do not include "OM" after the model numbers will not be able to use this feature.

To configure all ports for optical monitoring, use the following command:

```
BigIron RX(config)# optical-monitor
```

To configure a specific port for optical monitoring, use the following command:

```
BigIron RX(config)# interface ethernet 1/1  
BigIron RX(config-if-e10000-1/1)# optical-monitor
```

To configure a range of ports for optical monitoring, use the following command:

```
BigIron RX(config)# interface ethernet 1/1 to 1/2  
BigIron RX(config-mif-e10000-1/1-1/2)# optical-monitor
```

**Syntax:** [no] optical-monitor <alarm-interval>

The optional <alarm-interval> variable sets the interval in minutes between which alarms or messages are sent. The default interval is three minutes.

## 4 Connecting a BigIron RX Series switch

You can view the optical monitoring information using the **show optic** command as displayed in the following:

```
BigIron RX#show optic 4
Port Temperature      Tx Power          Rx Power          Tx Bias Current Monitor
+-----+-----+-----+-----+
 4/1  30.8242 C  -001.8822 dBm  -002.5908 dBm   41.790 mA
      Normal      Normal          Normal          Normal
 4/2  31.7070 C  -001.4116 dBm  -006.4092 dBm   41.976 mA
      Normal      Normal          Normal          Normal
 4/3  30.1835 C           Low-Alarm      -000.5794 dBm   0.000 mA
      Normal          Normal          Normal          Low-Alarm
 4/4  0.0000 C           Normal          Normal          0.000 mA
      Normal          Normal          Normal          Normal
```

**Syntax:** show optic <slot>

The <slot> variable specifies the slot in the switch chassis that you want to monitor optical information from.

### Cleaning fiber optic modules

To avoid problems with the connection between the fiber optic module port and the fiber cable connector, Brocade strongly recommends cleaning both connectors before making this connection. In particular, dust can accumulate in either connector and cause problems such as reducing the optic launch power.

To clean the fiber cable connectors, Brocade recommends using a fiber optic reel-type cleaner. You can purchase this type of cleaner from the following Website:

<http://www.fisfiber.com/>

When not using a fiber optic module port connector, make sure to keep the protective covering on.

## Troubleshooting network connections

After you cable the fiber optic modules, you can observe certain LEDs to determine if the network connections are functioning properly. [Table 16](#) outlines the LEDs related to the network connections, the desired state of each LED, possible abnormal states of each LED, and what to do if an LED indicates an abnormal state.

**TABLE 16** Network connection-related LED states

LED	Desired State	Meaning	Abnormal state	Meaning or action
<b>Interface module</b>				
Link	On	A link is established with the remote port.	Off	<p>A link is not established with the remote port. You can do the following:</p> <ul style="list-style-type: none"> <li>• Verify that the connection to the other network device has been properly made. Also, make certain that the other network device is powered on and operating correctly.</li> <li>• Verify that the transmit port on a BigIron RX Series switch is connected to the receive port on the other network device, and that the receive port on the BigIron RX Series switch is connected to the transmit port on the other network device. If you are not certain, remove the two cable connectors from the port connector and reinsert them in the port connector, reversing their order.</li> <li>• Dust may have accumulated in the cable connector or port connector. For information about cleaning the connectors, refer to <a href="#">"Cleaning fiber optic modules"</a> on page 108.</li> <li>• If the other actions do not resolve the problem, try using a different port or a different cable.</li> </ul>
Active	On or blinking	The port is transmitting and receiving user packets.	Off for an extended period.	<p>The port is not transmitting or receiving user packets. You can do the following:</p> <ul style="list-style-type: none"> <li>• Check the Link LED to make sure the link is still established with the remote port. If not, take the actions described in the Meaning or Action column for the Link LED.</li> <li>• Verify that the port has not been disabled through a configuration change. You can use the CLI. If you have configured an IP address on the device, you also can use the Web management interface or IronView Network Manager.</li> </ul>

If a problem persists after taking these actions, contact Brocade's technical support.

# Testing network connectivity

After you cable the fiber optic modules, you can test connectivity to other network devices by pinging those devices. You also can perform trace routes.

To resolve problems that may arise with network connections:

- For the indicated port, verify that both ends of the cabling (at the Brocade device and the connected device) are snug.
- Verify that the Brocade device and the connected device are both powered on and operating correctly.
- Verify that you have used the correct cable type for the connection:
  - For twisted-pair connections to an end node, use straight-through cabling.
  - For fiber optic connections, verify that the transmit port on the device is connected to the receive port on the connected device, and that the receive port on device is connected to the transmit port on the connected device.
- Verify that the port has not been disabled through a configuration change. You can use the CLI. If you have configured an IP address on the device, you also can use the Web management interface or IronView Network Manager.
- For copper ports, you can test the cable using Virtual Cable Testing. Refer to [“Using virtual cable testing to diagnose a cable”](#) on page 111.
- If the other procedures do not resolve the problem, try using a different port or a different cable.

## Pinging an IP address

To verify that a BigIron RX Series switch can reach another device through the network, enter a command such as the following at any level of the CLI on the BigIron RX Series switch:

```
BigIron RX> ping 192.33.4.7
```

**Syntax:** ping <ip addr> | <hostname> [source <ip addr>] [count <num>] [timeout <msec>] [ttl <num>] [size <byte>] [quiet] [numeric] [no-fragment] [verify] [data <1-to-4 byte hex>] [brief]

---

### NOTE

If you address the ping to the IP broadcast address, the device lists the first four responses to the ping.

---

## Tracing a route

To determine the path through which a BigIron RX Series switch can reach another network device, enter a command such as the following at any level of the CLI on the BigIron RX Series switch:

```
BigIron RX> traceroute 192.33.4.7
```

**Syntax:** traceroute <host-ip-addr> [maxttl <value>] [minttl <value>] [numeric] [timeout <value>] [source-ip <ip addr>]

The CLI displays trace route information for each hop as soon as the information is received. Traceroute requests display all responses to a given TTL. In addition, if there are multiple equal-cost routes to the destination, the Brocade device displays up to three responses by default.

Refer to the *BigIron RX Series Configuration Guide* for information about the command syntax.

## Using virtual cable testing to diagnose a cable

BigIron RX devices support **Virtual Cable Test (VCT)** technology. VCT technology enables you to diagnose a conductor (wire or cable) by sending a pulsed signal into the conductor, then examining the reflection of that pulse. This method of cable analysis is referred to as Time Domain Reflectometry (TDR). By examining the reflection, the Brocade device can detect and report cable statistics such as, local and remote link pair, cable length, and link status.

### *Configuration notes*

- This feature is supported on copper ports only. It is not supported on fiber ports.
- The port to which the cable is connected must be enabled when you issue the command to diagnose the cable. If the port is disabled, the command is rejected.
- If the port is operating at 100 Mbps half-duplex, the TDR test on one pair will fail.
- If the remote pair is set to forced 100 Mbps, any change in MDI or MDIX may cause the device to interpret the Multilevel Threshold-3 (MLT-3) as a reflected pulse, in which case, the device will report a faulty condition. In this scenario, it is recommended that you run the TDR test a few times for accurate results.

### *Command syntax*

To diagnose a cable using TDR, enter commands such as the following at the Privileged EXEC level of the CLI:

```
BigIron RX# phy cable-diag tdr 1
```

The above command diagnoses the cable attached to port 1.

**Syntax:** phy cable-diag tdr <slot-num/port-num>

### *Viewing the results of the cable analysis*

To display the results of the cable analysis, enter a command such as the following at the Privileged EXEC level of the CLI:

```
BigIron RX#sh cable-diag tdr 1
Port      Speed Local pair Pair Length Remote pair Pair status
-----
01        1000M Pair A    <50M      Pair B    Terminated
          Pair B    <50M      Pair A    Terminated
          Pair C    <50M      Pair D    Terminated
          Pair D    <50M      Pair C    Terminated
```

**Syntax:** show cable-diag tdr <slot-num/port-num>

[Table 17](#) defines the fields shown in the command output.

## 4 Testing network connectivity

**TABLE 17** Cable statistics

This line...	Displays...
Port	The interface that was tested.
Speed	The port's current line speed.
Local pair	The local link name.
Pair Length	The cable length when terminated, or the distance to the point of fault when the line is not up.
Remote pair	The remote link name.
Pair status	The status of the link. This field displays one of the following: <ul style="list-style-type: none"><li>• Terminated: The link is up</li><li>• Shorted: A short is detected in the cable</li><li>• Open: An opening is detected in the cable</li><li>• ImpedMis: The impedance is mismatched</li><li>• Failed: The TDR test failed</li></ul>



# Managing the BigIron RX Series Chassis and Modules

---

## In this chapter

- [Managing the BigIron RX Series chassis . . . . .](#) 113
- [Managing the cooling system . . . . .](#) 117
- [Managing the interface modules . . . . .](#) 123
- [Enabling and disabling management module CPU usage calculations . .](#) 131
- [Displaying management module CPU usage . . . . .](#) 132
- [Enabling and disabling packet logging for management and interface modules](#) 133
- [Removing MAC address entries . . . . .](#) 135

## Managing the BigIron RX Series chassis



### **DANGER**

*The procedures in this manual are for qualified service personnel.*

This chapter contains information about refining the configuration of, monitoring, and managing the BigIron RX Series hardware components

You can perform the following management tasks for the BigIron RX Series chassis:

- Display chassis status and temperatures of all hardware components
- Display the Syslog configuration and static and dynamic buffers

### **Displaying chassis status and temperature readings**

You can display the following information related to the BigIron RX Series chassis:

- Slot power-on priority
- Status of the fans
- Temperature readings of the management, switch fabric, interface, and fan control modules and the interval at which the system reads the temperature of these modules
- The MAC address of the BigIron RX Series chassis

To display this information, enter the following command at any level of the CLI:

```
BigIron RX# show chassis
*** BigIron RX-4 CHASSIS ***
---POWERS ---
AC Powers Are Used.
Power 1: Installed (OK)
Power 2: not present
Power 3: not present
Slot Power-On Priority:
Slot1 (pri=1)
Slot2 (pri=1)
Slot3 (pri=1)
Slot4 (pri=1)
--- FANS ---
Right Fan Tray: Fan 5: Status = OK, Speed = LOW (50%) (RPM 3333)
Right Fan Tray: Fan 6: Status = OK, Speed = LOW (50%) (RPM 3409)
--- TEMPERATURE READINGS ---
Active Mgmt Module: 32.500C 54.625C (CPU)
SNM1: 27.5C
SNM2: 30.5C
SNM3: 30.5C
LP2 Sensor1: 41.0C
Temperature Monitoring Poll Period is 60 seconds
--- MISC INFO ---
Backplane EEPROM MAC Address: 000a.80a0.2000
```

The display shows the following information:

**TABLE 18 Chassis status and temperature information**

This field...	Displays...
<b>Powers</b>	
Power BigIron RX-4: 1 – 3 BigIron RX-8: 1 – 4 BigIron RX-16: 1 – 8 BigIron RX-32: 1 – 8	Indicates whether an AC power supply is installed in the specified power supply slot and the status of the power supply, which can be one of the following: <ul style="list-style-type: none"> <li>Installed (OK) – The power supply is functioning properly and supplying power to the chassis and installed modules.</li> <li>Failed – The power supply is not functioning and is not supplying power to the chassis and installed modules.</li> <li>not present – There is no power supply installed in the slot.</li> </ul>
Slot Power-On Priority	The configured power-on priority of each interface modules installed in a chassis slot.
Slot1 – Slot16 BigIron RX-4: Slot1 – Slot4 BigIron RX-8: Slot1 – Slot8 BigIron RX-16: Slot1 – Slot16 BigIron RX-32: Slot1 – Slot32	The priority of each chassis slot as configured by the <b>lp-slot-priority</b> command. The priority can be 1 – 8, where 1 is the lowest priority and 8 is the highest priority. (The default priority is 1.) If the supply of power to the chassis falls below a minimum threshold, the chassis slots with the lowest priority will likely lose power. For information about using the <b>lp-slot-priority</b> command, refer to <a href="#">“Changing priority of chassis slots for interface modules”</a> on page 129.
<b>Fans</b>	
Fan <number>	Information about fans in the BigIron RX Series chassis.

**TABLE 18** Chassis status and temperature information (Continued)

This field...	Displays...
Status	The status of a fan can be one of the following: <ul style="list-style-type: none"> <li>• OK – The fan is functioning properly and is keeping the temperature of each module within an acceptable temperature range.</li> <li>• Failed – The fan is not functioning properly or the fan control module cannot control the fan.</li> </ul>
Speed	The speed of a fan can be one of the following: <ul style="list-style-type: none"> <li>• Low – The fan is functioning at 50 percent of capacity.</li> <li>• Medium – The fan is functioning at 75 percent of capacity.</li> <li>• Medium-high – The fan is functioning at 90 percent of capacity.</li> <li>• High – The fan is functioning at 100 percent of capacity.</li> </ul>
<b>Temperature Readings</b>	
Active and Standby Mgmt Module	The temperature of the active and standby management modules.
Fan <number>	The temperature of fan0 and fan1.
SNM<number>	The temperature of the switch fabric module.
Temperature Monitoring Poll Period	The interval at which the system reads the temperature sensor on the management, switch fabric, interface, and fan control modules.
<b>Misc Info</b>	
Backplane EEPROM MAC Address	The MAC address of the BigIron RX Series chassis.

## Displaying the Syslog configuration and static and dynamic buffers

For information about configuring Syslog, refer to the *BigIron RX Series Configuration Guide*

To display the Syslog parameters currently in effect on a BigIron RX Series switch, enter the following command from any level of the CLI:

```
BigIron RX> show logging
Syslog logging: enabled (0 messages dropped, 0 flushes, 0 overruns)
  Buffer logging: level ACDMEINW, 7 messages logged
  level code: A=alert C=critical D=debugging M=emergency E=error
              I=informational N=notification W=warning
...
```

**Syntax:** show logging

The Syslog display shows the following configuration information, in the rows above the log entries themselves.

**TABLE 19** Syslog buffer configuration

This field...	Displays...
Syslog logging	The state (enabled or disabled) of the Syslog buffer.
messages dropped	The number of Syslog messages dropped due to user-configured filters. By default, the software logs messages for all Syslog levels. You can disable individual Syslog levels, in which case the software filters out messages at those levels. Each time the software filters out a Syslog message, this counter is incremented.

**TABLE 19 Syslog buffer configuration (Continued)**

This field...	Displays...
flushes	The number of times the Syslog buffer has been cleared by the <b>clear logging</b> command. For information about clearing the Syslog buffer, refer to “ <a href="#">Static and dynamic buffers</a> ” on page 116.
overruns	The number of times the dynamic log buffer has filled up and been cleared to hold new entries. For example, if the buffer is set for 100 entries, the 101st entry causes an overrun. After that, the 201st entry causes a second overrun.
level	The message levels that are enabled. Each letter represents a message type and is identified by the key (level code) below the value. If you disable logging of a message level, the code for that level is not listed.
messages logged	The total number of messages that have been logged since the software was loaded.
level code	The message levels represented by the one-letter codes.

### *Static and dynamic buffers*

The software provides two separate buffers:

- Static – logs power supply failures, fan failures, and temperature warning or shutdown messages
- Dynamic – logs all other message types

In the static log, new messages replace older ones, so only the most recent message is displayed. For example, only the most recent temperature warning message will be present in the log. If multiple temperature warning messages are sent to the log, the latest one replaces the previous one. The static buffer is not configurable.

The message types that appear in the static buffer do not appear in the dynamic buffer. The dynamic buffer contains up to the maximum number of messages configured for the buffer (50 by default), then begins removing the oldest messages (at the bottom of the log) to make room for new ones.

The static and dynamic buffers are both displayed when you display the log.

```
BigIron RX(config)# show logging
...
Static Log Buffer:
Aug 27 12:42:42:A:Power Supply 6, 1st right, failed

Dynamic Log Buffer (50 lines):
Aug 27 12:19:04:I:Interface ethernet3/4, state up
Aug 27 12:19:04:I:Interface ethernet6/3, state up
Aug 27 12:19:04:I:Interface ethernet3/2, state up
Aug 27 12:19:04:I:Interface ethernet6/1, state up
Aug 27 12:19:00:N:Module up in slot 6
Aug 27 12:19:00:N:Module up in slot 3
Aug 27 12:18:43:I:Warm start
```

When you clear log entries, you can selectively clear the static or dynamic buffer, or you can clear both. For example, to clear only the dynamic buffer, enter the following command at the Privileged EXEC level:

```
BigIron RX# clear logging dynamic-buffer
```

**Syntax:** clear logging [dynamic-buffer | static-buffer]

You can specify the **dynamic-buffer** keyword to clear the dynamic buffer or the **static-buffer** keyword to clear the static buffer. If you do not specify a buffer, both buffers are cleared.

## Managing the cooling system

This section provides configuration, management, and monitoring information about the BigIron RX Series cooling system.

### Configuring the cooling system

The BigIron RX Series switch provides default settings for all cooling system parameters. Therefore, no initial configuration of the cooling system is necessary. If desired, you can change the settings of the following cooling system parameters:

- Low and high temperature thresholds for modules and fan speeds
- Interval at which the system polls the temperature sensors on the module for a reading

### *Changing temperature thresholds for modules and fan speeds*

The BigIron RX Series cooling system includes fans that operate at speeds of low, medium, medium-high, and high. In general, each fan speed, except for low, has a low and high temperature threshold associated with it as shown in Figure 72. The low fan speed has a high temperature threshold only.

**FIGURE 72** Fan speeds and temperature thresholds

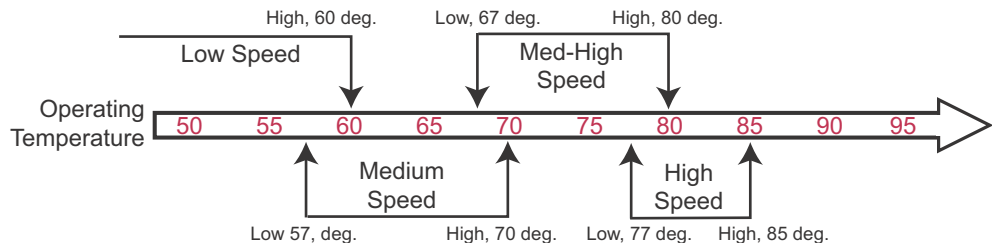

The low and high temperature thresholds enable the BigIron RX Series system to determine at which speed the fans should operate. In general, the fans operate as follows:

- If the temperature of all modules falls between the low and high thresholds for a fan speed, the fan continues to operate at that fan speed.
- If the temperature of a management module or the switch fabric module or an interface modules exceeds the high threshold specified for a fan speed, the fan increases its speed to the next higher speed. On the cards with two sensors, each is monitored individually and if either exceeds the threshold limits, then the fan will increase. If the temperature of any of these modules exceeds the high threshold for the high speed for three minutes (the actual number of polls is determined by the setting of the **temp-poll-period** command), the system shuts down the modules to prevent damage. (For information about **temp-poll-period** command, refer to “[Changing the temperature polling interval](#)” on page 121.)

- If the temperature of a management module, the switch fabric module, and all interface modules falls below the low threshold for a fan speed, the fan decreases its speed to the next lower speed. If the temperature of all modules falls below the high threshold for the low speed, the fan operates at the low speed.

If the temperature of a management module or the switch fabric module or an interface modules exceeds the high temperature threshold for any of the fan speeds, the system sends a warning message to the system log and an SNMP trap. For information about viewing the warning messages, refer to [“Displaying temperature warnings”](#) on page 122.

[Table 20](#) outlines the default low and high temperature thresholds for each module and fan speed.

**TABLE 20** Default low and high temperature thresholds for modules and fan speeds

Fan speed	Low temperature threshold	High temperature threshold
<b>Management module (active and standby)</b>		
High	77° C	85° C
Medium-high	67° C	80° C
Medium	57° C	70° C
Low	-1° C	60° C
<b>Management module CPU (on active and standby modules)</b>		
High	72° C	85° C
Medium-high	67° C	80° C
Medium	57° C	70° C
Low	-1° C	60° C
<b>Interface modules</b>		
High	56° C	95° C
Medium-high	51° C	60° C
Medium	46° C	55° C
Low	-1° C	50° C
<b>Switch fabric module</b>		
High	77° C	85° C
Medium-high	67° C	80° C
Medium	57° C	70° C
Low	-1° C	60° C

For information about checking the current settings of the low and high temperature thresholds for modules and fan speeds, refer to [“Displaying temperature thresholds for modules and fan speeds”](#) on page 120.

If desired, you can change the default low and high temperature thresholds for a particular module and fan speed. For example, to change the low and high thresholds of the medium fan speed for the management modules to 56° C and 72° C, respectively, enter the following command at the global CONFIG level of the CLI:

```
BigIron RX(config)# fan-threshold mp med 56 72
```

**Syntax:** fan-threshold <module> [low <high-threshold>] [med <low-threshold> <high-threshold>]  
[med-hi <low-threshold> <high-threshold>] [hi <low-threshold> <high-threshold>]

For the <module> parameter, you can specify the following:

- lp – Changes low and high temperature thresholds for the interface modules.
- mp – Changes low and high temperature thresholds for the active and standby management modules.
- mp-cpu – Changes low and high temperature thresholds for the active and standby management module's CPU.
- switch fabric – Changes low and high temperature thresholds for the switch fabric module.

For the <low-threshold> and <high-threshold> parameters, you can specify any temperature in Centigrade. However, when changing low and high temperature thresholds for a module's fan speeds, remember that the low temperature threshold of a higher fan speed must be lower than the high temperature threshold of the lower fan speed. Brocade establishes this guideline to ensure the fan speed stability.

For example, if you are changing the temperature thresholds for a management module's high and medium-high fans speeds, the BigIron RX Series system will accept the following values because the low temperature threshold for the high speed (77° C) is lower than the high temperature threshold (79° C) for the medium-high speed.

```
BigIron RX(config)# fan-threshold mp med-hi 67 79  
BigIron RX(config)# fan-threshold mp hi 77 85
```

However, the BigIron RX Series system will not accept the following values because the low temperature threshold being entered for the high speed (77× C) is higher than the high temperature threshold (76× C) for the medium-high speed.

```
BigIron RX(config)# fan-threshold mp med-hi 67 76  
BigIron RX(config)# fan-threshold mp hi 77 85
```

### Displaying temperature thresholds for modules and fan speeds

To check the current settings of the low and high temperature thresholds for modules and fan speeds, you can enter the following command at any level of the CLI:

```
BigIron RX# show fan-threshold
=== Thermal Sensor Control Block (THERMAL_SENSOR_TEST_RULE_MP) ===
Fan Speed Low: -1 - 60
Fan Speed Med: 57 - 70
Fan Speed Med-Hi: 67 - 80
Fan Speed Hi: 77 - 85
state = 0 (FAN_STATE_LOW)
max_ts_shut_off_count = 3
shut_off_count = 0 0 0 0 0 0 0 0 0 0 0 0 0 0 0 0
=== Thermal Sensor Control Block (THERMAL_SENSOR_TEST_RULE_SNM) ===
Fan Speed Low: -1 - 60
Fan Speed Med: 57 - 70
Fan Speed Med-Hi: 67 - 80
Fan Speed Hi: 72 - 85
state = 0 (FAN_STATE_LOW)
max_ts_shut_off_count = 3
shut_off_count = 0 0 0 0 0 0 0 0 0 0 0 0 0 0 0 0
=== Thermal Sensor Control Block (THERMAL_SENSOR_TEST_RULE_LP) ===
Fan Speed Low: -1 - 50
Fan Speed Med: 46 - 55
Fan Speed Med-Hi: 51 - 60
Fan Speed Hi: 56 - 85
state = 0 (FAN_STATE_LOW)
max_ts_shut_off_count = 3
shut_off_count = 0 0 0 0 0 0 0 0 0 0 0 0 0 0 0 0
=== Thermal Sensor Control Block (THERMAL_SENSOR_TEST_RULE_STANDBY_MP) ===
Fan Speed Low: -1 - 60
Fan Speed Med: 57 - 70
Fan Speed Med-Hi: 67 - 80
Fan Speed Hi: 77 - 85
state = 0 (FAN_STATE_LOW)
max_ts_shut_off_count = 3
shut_off_count = 0 0 0 0 0 0 0 0 0 0 0 0 0 0 0 0
=== Thermal Sensor Control Block (THERMAL_SENSOR_TEST_RULE_MP_CPU) ===
Fan Speed Low: -1 - 60
Fan Speed Med: 57 - 70
Fan Speed Med-Hi: 67 - 80
Fan Speed Hi: 77 - 85
state = 0 (FAN_STATE_LOW)
max_ts_shut_off_count = 3
shut_off_count = 0 0 0 0 0 0 0 0 0 0 0 0 0 0 0 0
=== Thermal Sensor Control Block (THERMAL_SENSOR_TEST_RULE_STANDBY_MP_CPU) ===
Fan Speed Low: -1 - 60
Fan Speed Med: 57 - 70
Fan Speed Med-Hi: 67 - 80
Fan Speed Hi: 77 - 85
state = 0 (FAN_STATE_LOW)
max_ts_shut_off_count = 3
shut_off_count = 0 0 0 0 0 0 0 0 0 0 0 0 0 0 0 0
```

**Syntax:** show fan-threshold



The display shows the following information:

**TABLE 21** Temperature threshold information for modules and fan speeds

This field...	Displays...
Thermal Sensor Control Block (THERMAL_SENSOR_TEST_RULE_<module>)	The temperature threshold information for the various modules. The <module> parameter indicates the following: <ul style="list-style-type: none"> <li>• MP – The active management module</li> <li>• STANDBY_MP – The standby management module</li> <li>• SNM – The switch fabric module</li> <li>• LP – An interface module</li> </ul>
Fan Speed Low or Med or Med-Hi or Hi	The current setting of the low and high temperature thresholds for the low, medium, medium-high, and high fan speeds. <p><b>NOTE:</b> As indicated in <a href="#">Table 20</a> on page 118, the low fan speed for each module does not have a default low temperature threshold value, nor can you configure this value. The “-1” value that appears in the Fan Speed Low field for each module is a Brocade internal value only.</p>
State = 0 (FAN_STATE_LOW)	For Brocade internal use only.
max_ts_shut_off_count	
shut_off_count = 0 0 0 0 0 0 0	For Brocade internal use only.

### *Changing the temperature polling interval*

By default, the BigIron RX Series system reads the temperature sensor on each module every 60 seconds. To change the interval at which the system reads the temperature sensors on each module, enter a command such as the following at the global CONFIG level of the CLI:

```
BigIron RX(config)# temp-poll-period 120
```

**Syntax:** temp-poll-period <seconds>

For the <seconds> parameter, you can specify a value from 30 – 120. You can also specify 0, which disables the system from polling the temperature sensor on each module.

### **Manually setting the fan speed**

Typically, the management module, in conjunction with default settings of low and high temperature thresholds, determines the speed of the two four-speed fans. (For information about changing the low and high temperature thresholds, refer to [“Changing temperature thresholds for modules and fan speeds”](#) on page 117.) If desired, you can manually set the speed of the fans. The **set-fan-speed** command in the Privileged EXEC level of the CLI allows you to manually set the speed of the fans.

For example, to set the speed of fan 0 to medium-high, enter the following command:

```
BigIron RX(config)# set-fan-speed med-hi
```

**Syntax:** set-fan-speed <fan-speed>

For the <fan-speed> parameter, you can specify the following:

auto – The system is adjusted by the monitoring system.

hi – The system sets the fan speed to high.

low – The system sets the fan speed to low.

med – The system sets the fan speed to medium.

med-high – The system sets the fan speed to medium-high.

## Monitoring the cooling system

You can monitor the following aspects of the BigIron RX Series cooling system:

- The temperature of the fan control modules
- The status and speed of the fans
- The temperature warnings sent to the system log and that generate an SNMP trap

### *Displaying fan tray status and speed*

The CLI provides two commands that allow you to display the status and speed of the four-speed fans in the BigIron RX Series chassis. To display this information, you can enter the following command at any level of the CLI:

```
BigIron RX# show chassis
...
--- FANS ---
Right Fan Tray: Fan 5: Status = OK, Speed = LOW (50%) (RPM 3333)
Right Fan Tray: Fan 6: Status = OK, Speed = LOW (50%) (RPM 3488)...
```

**Syntax:** show chassis

For information about all output generated by the **show chassis** command, refer to [“Displaying chassis status and temperature readings”](#) on page 113.

**TABLE 22 Fan status and speed fields**

This field...	Displays...
Status	<p>The status can be one of the following:</p> <ul style="list-style-type: none"> <li>• OK – The fan is functioning properly and is keeping the temperature of each module within an acceptable temperature range.</li> <li>• Failed – The fan is not functioning properly or the fan control module cannot control the fan.</li> </ul>
Speed	<p>The speed can be one of the following:</p> <ul style="list-style-type: none"> <li>• LOW – The fan is functioning at 50 percent of capacity</li> <li>• MEDIUM – The fan is functioning at 75 percent of capacity</li> <li>• MEDIUM-HIGH – The fan is functioning at 90 percent of capacity</li> <li>• HIGH – The fan is functioning at 100 percent of capacity</li> </ul>

### *Displaying temperature warnings*

If the temperature of a module exceeds the high temperature threshold for any of the fan speeds, the system sends a warning message to the system log and an SNMP trap. (For more information about the low and high temperature thresholds, refer to [“Changing temperature thresholds for modules and fan speeds”](#) on page 117.) This section describes how to view the system log. If you have configured the BigIron RX Series system to use a Syslog server or SNMP trap receiver, refer to the documentation for the server or receiver.

To display the system log, enter the following command at any CLI level:

```
BigIron RX# show log
```

**Syntax:** show log

## Managing the interface modules

This section contains the following information:

- Configuring interface module boot parameters
- Changing the priority of chassis slots for interface modules
- Disabling and reenabling power to the interface modules

### Configuring interface module boot parameters

The Ethernet interface module has its own system software and boots after the management module boots. By default, the following boot-related events occur:

- The BigIron RX Series system synchronizes or prompts you to synchronize the interface modules' IronWare images between the management module and the interface modules.
- The interface modules boot from a source specified by the management module (the default source is a primary IronWare image in the interface modules' flash memory).

If desired, you can change the following:

- Disable the synchronization of IronWare images between the management and all interface modules. You can also initiate an immediate synchronization.
- Change the boot source of one or all interface modules.

### Synchronizing the interface module's IronWare images between management and interface modules

An interface module can have two IronWare images: primary and secondary. These images contain the layer 1 – 3 software that the interface modules run. These images reside in the interface module's flash memory. Either the primary or secondary image is run by the interface module from this location.

If you copy the primary or secondary IronWare image to all interface modules using the **copy** command with the **all** keyword, the management module makes a copy of the file and stores it in its code flash under the names `lp-primary-0` or `lp-secondary-0`. The images are stored in this location only and are not run by the management module or the interface modules. If you copy the primary or secondary IronWare image to a specified chassis slot using the **copy** command with the `<chassis-slot-number>` parameter, the management module does not make a copy of the file.

If the management module has a copy of the primary or secondary IronWare image in its code flash, by default, the BigIron RX Series system synchronizes or prompts you to synchronize the interface modules' IronWare images between the management module and the interface modules during bootup. When the BigIron RX Series system synchronizes the IronWare images, the management module copies the IronWare images from its code flash to the interface modules' code flash (the interface modules' default boot source).

The system allows you to manage synchronization of the IronWare images between management and interface modules in the following situations:

- You are prompted to synchronize the IronWare images during bootup.
- You want to initiate an immediate synchronization; for example, you want an immediate update of the IronWare images on one or all interface modules.
- You want to disable synchronization; for example, you have upgraded the IronWare image of one interface module but want to continue running the older image on all other interface modules.

The following section discuss how to manage the IronWare image synchronization in these situations.

### *Synchronizing the interface modules' IronWare images during bootup*

By default, the BigIron RX Series system checks the IronWare images in the interface module's flash memory during boot to ensure they are the same as the IronWare images in the management module's flash memory. If an interface module does not have a IronWare image, the system automatically downloads the image from the management module's flash memory to the interface module's flash memory.

If an interface module has different IronWare images, the system prompts you to do the following:

- If you want to update the primary and secondary IronWare images in the interface module's flash memory with the images in the management module's flash memory, enter the **lp cont-boot sync <slot-number>** command at the Privileged EXEC prompt.
- If you want to retain the IronWare images in the interface module's flash memory, enter the **lp cont-boot no-sync <slot-number>** command at the Privileged EXEC prompt.

### *Specifying an immediate synchronization*

You can immediately synchronize the IronWare images between the management module and one or all interface modules. For example, to immediately synchronize the IronWare images between the management module and all interface modules, enter the following command at the Privileged EXEC level:

```
BigIron RX# lp sync all
```

**Syntax:** lp sync all | <slot-number>

The **all** keyword indicates that the immediate synchronization applies to all interface modules in the BigIron RX Series chassis.

The <slot-number> parameter specifies the BigIron RX Series chassis slot number that contains the interface module to which the immediate synchronization applies. You can specify 1 – 4 for BigIron RX-4, 1 – 8 for BigIron RX-8 or 1 – 16 for BigIron RX-16.

### *Disabling or reenabling an automatic check and synchronization*

By default, the BigIron RX Series system checks the IronWare images in the interface module's flash memory during bootup to ensure it is the same as the IronWare images in the management module's flash memory. For information about what the system does if the interface module does not currently have a IronWare image or if the image is different from that of the management module, refer to [“Synchronizing the interface modules' IronWare images during bootup”](#) on page 124.

To disable the automatic check and synchronization during bootup, enter the following command at the global CONFIG level:

```
BigIron RX(config)# lp disable-lp-sync-check
```

**Syntax:** lp disable-lp-sync-check

Provided that you save this configuration by entering the **write memory** command, the system will disable the automatic check and synchronization of the IronWare images starting with the next software reload or system reset and each reload or reset after that.

To re-enable the automatic check and synchronization of the IronWare images during bootup, enter the following command at the global CONFIG level:

```
BigIron RX(config)# no lp disable-lp-sync-check
```

**Syntax:** no lp disable-lp-sync-check

### *Changing the boot source*

By default, the interface modules boot from the primary IronWare image located in the interface modules' flash memory. If desired, you can change the boot source of one or all interface modules to one of the following sources:

- Management module
  - PCMCIA flash card in slot 1 or 2
  - Primary or secondary IronWare image in the management module's flash memory
- Interface module
  - Secondary IronWare image in interface module's flash memory
- TFTP server

You can also specify an interactive boot, which allows you to enter a separate command after the interface module comes up. The command specifies the source from which one or all interface modules should boot.

When changing the boot source for one or all interface modules, you can specify one of the following:

- An immediate boot for one interface module from a specified source.
- An automatic boot for one or all interface modules from a specified source starting with the next software reload or system reset and each reload or reset after that.

The CLI command for specifying an immediate boot for one interface module is the same as that for specifying an automatic boot for one or all modules. The only difference is the CLI level from which you specify the command. You must specify the command for an immediate boot in the Privileged EXEC level and the command for an automatic boot in the global CONFIG level.

The following sections explain how to specify an immediate boot and an automatic boot.

## **Specifying an immediate boot**

You can specify an immediate boot for one interface module from a specified source by entering the **lp boot system** command in the Privileged EXEC level. The entered command will override the default or configured boot source one time only.

### *Specifying an immediate boot from the management module's PCMCIA slots*

For example, to specify an immediate boot for the interface module installed in slot 1 from the management module's PCMCIA slot 1, enter the following command at the Privileged EXEC level of the CLI:

```
BigIron RX# lp boot system slot1 primary 1
```

**Syntax:** lp boot system slot1 | slot2 <filename> <slot-number>

The **slot1** and **slot2** keywords indicate the management module's PCMCIA slot from which to boot the interface module.

The <filename> parameter specifies the name of the image from which to boot the interface module.

The <slot-number> parameter specifies the BigIron RX chassis slot number that contains the interface module that will undergo an immediate boot. You can specify 1 – 4 for BigIron RX-4, 1 – 8 for BigIron RX-8 or 1 – 16 for BigIron RX-16.

### *Specifying an immediate boot from the management module's flash memory*

For example, to specify an immediate boot from the primary IronWare image in the management module's flash memory for the interface module installed in slot 1, enter the following command at the Privileged EXEC level of the CLI:

```
BigIron RX# lp boot system mp primary 1
```

**Syntax:** lp boot system mp primary | secondary <slot-number>

The **primary** and **secondary** keywords specify the primary or secondary IronWare image in the management module's flash memory.

The <slot-number> parameter specifies the BigIron RX Series chassis slot number that contains the interface module that will undergo an immediate boot. You can specify 1 – 4 for BigIron RX-4, 1 – 8 for BigIron RX-8 or 1 – 16 for BigIron RX-16.

### *Specifying an immediate boot from the interface module's flash memory*

For example, to specify an immediate boot from the primary IronWare image in the interface module's flash memory for the interface module installed in slot 1, enter the following command at the Privileged EXEC level of the CLI:

```
BigIron RX# lp boot system flash primary 1
```

**Syntax:** lp boot system flash primary | secondary <slot-number>

The **primary** and **secondary** keywords specify the primary or secondary IronWare image in the interface module's flash memory.

The <slot-number> parameter specifies the BigIron RX Series chassis slot number that contains the interface module that will undergo an immediate boot. You can specify 1 – 4 for BigIron RX-4, 1 – 8 for BigIron RX-8 or 1 – 16 for BigIron RX-16.

### *Specifying an immediate boot from a TFTP server*

For example, to specify an immediate boot for the interface module installed in slot 1 from a TFTP server, enter the following command at the Privileged EXEC level of the CLI:

```
BigIron RX# lp boot system tftp 123.123.123.123 primary 1
```

**Syntax:** lp boot system tftp <ip-address> <filename> <slot-number>

The <ip-address> parameter specifies the IP address of the TFTP server from which the interface module will be booted.

The <filename> parameter specifies the name of the image from which to boot the interface module.

The <slot-number> parameter specifies the BigIron RX Series chassis slot number that contains the interface module that will undergo an immediate boot. You can specify 1 – 4 for BigIron RX-4, 1 – 8 for BigIron RX-8 or 1 – 16 for BigIron RX-16.

### *Specifying an immediate interactive boot*

To specify an immediate interactive boot for the interface module installed in slot 1, enter the following command at the Privileged EXEC level of the CLI:

```
BigIron RX# lp boot system interactive 1
```

**Syntax:** lp boot system interactive <slot-number>

The <slot-number> parameter specifies the BigIron RX Series chassis slot number that contains the interface module that will undergo an immediate boot. You can specify 1 – 4 for BigIron RX-4, 1 – 8 for BigIron RX-8 or 1 – 16 for BigIron RX-16.

After you enter this command, the system enters the interface module's monitor mode. For example, to boot from the primary IronWare image in the interface module's flash memory, enter the following command at the monitor prompt:

```
LP MONITOR> boot system flash primary
```

### *Configuring an automatic boot*

You can configure an automatic boot for one or all interface modules from a specified source by entering the **lp boot system** command in the global CONFIG level. Provided that you save this configuration by entering the **write memory** command, the system will implement the automatic boot starting with the next software reload or system reset and each reload or reset after that.

### *Configuring an automatic boot from the management module's PCMCIA slot*

For example, to configure an automatic boot for all interface modules from the management module's PCMCIA slot 1, enter the following command at the global CONFIG level of the CLI:

```
BigIron RX(config)# lp boot system slot1 primary all
```

**Syntax:** lp boot system slot1 | slot2 <filename> all | <slot-number>

The **slot1** and **slot2** keywords indicate the management module's PCMCIA slot from which to boot the interface modules.

The <filename> parameter specifies the name of the image from which to boot the interface modules.

The **all** | <slot-number> parameter specifies that the automatic boot applies to all interface modules in the BigIron RX Series chassis or to an interface module in the specified chassis slot number only. You can specify 1 – 4 for BigIron RX-4, 1 – 8 for BigIron RX-8 or 1 – 16 for BigIron RX-16.

### *Configuring an automatic boot from the management module's flash memory*

For example, to configure an automatic boot from the primary IronWare image in the management module's flash memory for all interface modules, enter the following command at the global CONFIG level of the CLI:

```
BigIron RX(config)# lp boot system mp primary all
```

**Syntax:** lp boot system mp primary | secondary all | <slot-number>

The **primary** and **secondary** keywords specify the primary or secondary IronWare image in the management module's flash memory.

The **all** | <slot-number> parameter specifies that the automatic boot applies to all interface modules in the BigIron RX Series chassis or to an interface module in the specified chassis slot number only. You can specify 1 – 4 for BigIron RX-4, 1 – 8 for BigIron RX-8 or 1 – 16 for BigIron RX-16.

### *Configuring an automatic Bboot from the interface module's flash memory*

For example, to configure an automatic boot from the primary IronWare image in the interface module's flash memory for all interface modules, enter the following command at the global CONFIG level of the CLI:

```
BigIron RX(config)# lp boot system flash primary all
```

**Syntax:** lp boot system flash primary | secondary all | <slot-number>

The **primary** and **secondary** keywords specify the primary or secondary IronWare image in the interface module's flash memory.

The **all** | <slot-number> parameter specifies that the automatic boot applies to all interface modules in the BigIron RX Series chassis or to an interface module in the specified chassis slot number only. You can specify 1 – 4 for BigIron RX-4, 1 – 8 for BigIron RX-8 or 1 – 16 for BigIron RX-16.

### *Configuring an automatic boot from a TFTP server*

For example, to configure an automatic boot for all interface modules from a TFTP server, enter the following command at the global CONFIG level of the CLI:

```
BigIron RX(config)# lp boot system tftp 123.123.123.123 primary all
```

**Syntax:** lp boot system tftp <ip-address> <filename> all | <slot-number>

The <ip-address> parameter specifies the IP address of the TFTP server from which the interface modules will be booted.

The <filename> parameter specifies the name of the image from which to boot the interface modules.



The **all** | <slot-number> parameter specifies that the automatic boot applies to all interface modules in the BigIron RX Series chassis or to an interface module in the specified chassis slot number only. You can specify 1 – 4 for BigIron RX-4, 1 – 8 for BigIron RX-8 or 1 – 16 for BigIron RX-16.

### ***Configuring an automatic interactive boot***

For example, to configure an automatic interactive boot for all interface modules, enter the following command at the global CONFIG level of the CLI:

```
BigIron RX(config)# lp boot system interactive all
```

**Syntax:** lp boot system interactive all | <slot-number>

The **all** | <slot-number> parameter specifies that the automatic boot applies to all interface modules in the BigIron RX Series chassis or to an interface module in the specified chassis slot number only. You can specify 1 – 4 for BigIron RX-4, 1 – 8 for BigIron RX-8 or 1 – 16 for BigIron RX-16.

After you enter this command, the system enters the interface module's monitor mode. For example, to boot from the primary IronWare image in the interface module's flash memory, enter the following command at the monitor prompt:

```
LP MONITOR> boot system flash primary
```

## **Changing priority of chassis slots for interface modules**

You can prioritize the BigIron RX Series chassis slots in which the interface modules are installed. The priority range is 1 – 8, where 1 is the lowest priority and 8 is the highest priority. You can set one, some, or all chassis slots to the same priority or each chassis slot to a different priority. If you assign the same priority to all slots, the lowest-number slot has the highest priority, while the highest-numbered slot has the lowest priority.

By default, the priority of all chassis slots is 1, which is the lowest priority. If the supply of power to the chassis falls below a minimum threshold, the chassis slots will likely lose power because of their low priority. In this scenario for an BigIron RX-8 chassis, slot 8 will lose power first, then slot 7, slot 6, and so on until slot 1 loses power.

For example, to set the priority of chassis slot 1 to the highest priority (8), enter the following command:

```
BigIron RX(config)# lp-slot-priority 1 8
```

**Syntax:** lp-slot-priority <slot-number> <priority>

The <slot-number> parameter indicates that the chassis slot number for which you are changing the priority. You can specify slots 1 – 4 for BigIron RX-4, 1 – 8 for BigIron RX-8 or 1 – 16 for BigIron RX-16.

The <priority> parameter indicates that the priority of the chassis slot if the chassis loses power. You can specify a value of 1 – 8, where 1 is the lowest priority and 8 is the highest priority. You can set one, some, or all chassis slots to the same priority or each chassis slot to a different priority.

### Disabling and reenabling power to the interface modules

If needed, you can disable power to a specified interface module and then reenable it. For example, to disable power to the interface module in chassis slot 1, enter the following command at the Privileged EXEC level of the CLI:

```
BigIron RX# power-off lp 1
```

**Syntax:** power-off lp <slot-number>

The <slot-number> parameter indicates the chassis slot number for which you are disabling the power. You can specify slots 1 – 4 for BigIron RX-4, 1 – 8 for BigIron RX-8 or 1 – 16 for BigIron RX-16.

For example, to reenable power to the interface module in chassis slot 1, enter the following command at the Privileged EXEC level of the CLI:

```
BigIron RX# power-on lp 1
```

**Syntax:** power-on lp <slot-number>

The <slot-number> parameter indicates the chassis slot number for which you are re-enabling the power. You can specify slots 1 – 4 for BigIron RX-4, 1 – 8 for BigIron RX-8 or 1 – 16 for BigIron RX-16.

### Disabling and reenabling power to the switch fabric modules

If needed, you can disable power to a specified switch fabric module and then reenable it. For example, to disable power to the SFM, enter the following command at the Privileged EXEC level of the CLI:

```
BigIron RX# power-off snm 1
```

**Syntax:** power-off snm <number>

The <number> parameter indicates the switch fabric module number for which you are disabling the power. You can specify slots 0 – 4.

For example, to reenable power to the switch fabric module, enter the following command at the Privileged EXEC level of the CLI:

```
BigIron RX# power-on snm 1
```

**Syntax:** power-on snm < number>

The < number> parameter indicates the SFM number for which you are reenabling the power. You can specify 0 – 4.

---

#### NOTE

If you remove a SFM without powering off the SFM with the **power-off** command, the data in transit is lost.

---

## Enabling and disabling management module CPU usage calculations

You can enable the BigIron RX Series system to perform usage averaging calculations on tasks handled by the management module's CPU. If you enable the calculation performance, you can display usage averages for all tasks performed by the management module's CPU for an interval of up to 1 hour. You can display these statistics using the **show cpu** command. Typically, these statistics are used for debugging purposes.

By default, the performance of the calculations is disabled. When disabled, you can use the **show cpu** command without optional parameters to display usage averages for all tasks performed by the management module's CPU in the last 1 second.

To enable the performance of the usage averaging calculations, enter the following command at the global CONFIG level of the CLI:

```
BigIron RX(config)# cpu-usage on
```

**Syntax:** `cpu-usage on`

To disable the performance of the usage averaging calculations, enter the following command at the global CONFIG level of the CLI:

```
BigIron RX(config)# cpu-usage off
```

**Syntax:** `cpu-usage off`

---

### NOTE

When finished gathering statistics for debugging purposes, Brocade recommends disabling the usage averaging calculations, which are CPU-intensive and can affect the performance of the management module.

---

## Displaying management module CPU usage

You can display the tasks handled by the management module and the amount of the management module's CPU used by each task. To do so, enter the following command at any level of the CLI:

```
BigIron RX# show tasks
Task Name   Pri   State   PC         Stack        Size  CPU Usage(%)  task id  task vid
-----
idle 0      run    00001904  040560a0    256   66           0        0
monitor 20     susp  0000c658  0404bd80    8192   0            0        0
int 16     susp  0000c658  04051f90    16384  0            0        0
timer 15     susp  0000c658  04055f90    16384  0            0        0
dbg 30     susp  0000c658  0404df10    8192   0            0        0
flash 17     susp  0000c658  0409cf98    8192   0            0        0
wd 31     susp  0000c658  0409af80    8192   0            0        0
boot 17     susp  0000c658  041dbe30    65536  0            0        0
main 3      susp  0000c658  2060cf38    65536  0            0        1
itc 6      susp  0000c658  20610af0    16384  0            0        1
tmr 5      susp  0000c658  206a7638    16384  0            0        1
ip_rx 5      susp  0000c658  206aef48    16384  0            0        1
scp 5      susp  0000c658  206b3638    16384  0            0        1
console 5     susp  0000c658  206bf628    32768  0            0        1
vlan 5     susp  0000c658  206c6628    16384  0            0        1
mac_mgr 5    susp  0000c658  206d5638    16384  0            0        1
mrp_mgr 5    susp  0000c658  206db638    16384  0            0        1
vsrp 5     susp  0000c658  206e1630    16384  0            0        1
snms 5     susp  0000c658  206e5638    16384  0            0        1
rtm 5      susp  0000c658  20756638    16384  0            0        1
ip_tx 5     run    0000c658  20763638    16384  0            0        1
mcast 5     susp  0000c658  20767638    16384  0            0        1
l4 5      susp  0000c658  2076b630    16384  0            0        1
stp 5      susp  0000c658  20970628    16384  0            0        1
gvrp_mgr 5   susp  0000c658  20979638    16384  0            0        1
snmp 5     susp  0000c658  20982638    32768  0            0        1
web 5      susp  0000c658  2098d638    32768  0            0        1
lACP 5     susp  0000c658  20991638    16384  0            0        1
hw_access 5  susp  0000c658  20996638    16384  0            0        1
telnet_0 5     run    0000c658  209db638    32768  0            0        1
```

**Syntax:** show tasks

Examine the CPU Usage (%) field to determine the percentage of the management module's CPU used by each task.

---

### NOTE

The total CPU usage may not add up to 100 percent. The total may not include resources used by the management processes.

---

A problem could exist if the CPU usage is distributed unevenly to one task, other than the idle task, for a prolonged period. If this situation occurs, contact Brocade's technical support for assistance.

## Enabling and disabling packet logging for management and interface modules

You can enable the logging of packets transmitted, received, or both transmitted and received by a management or interface module in the BigIron RX Series chassis. If you enable packet logging, you can display the packet log using the **show packet-logging** command. (For information about displaying the contents of the packet log, refer to “[Displaying a packet log](#)” on page 134). Typically, the packet log is used for debugging purposes.

By default, packet logging is disabled for all management and interface modules. For example, to enable packet logging of packets transmitted and received by the interface module installed in chassis slot 1, enter the following command at the global CONFIG level of the CLI:

```
BigIron RX(config)# packet-logging 1 start 0
```

**Syntax:** packet-logging <slot-number> start <packet-direction>

For the <slot-number> parameter, you can specify 1 – 4 for BigIron RX-4, 1 – 8 for BigIron RX-8 or 1 – 16 for BigIron RX-16.

Specify the **start** keyword to start packet logging and write the log to the system’s memory. You must also specify the direction of packets that you want logged by entering one of the following for the <packet-direction> parameter:

- 0 – Logs packets transmitted and received by the specified module.
- 1 – Logs packets received by the specified module.
- 2 – Logs packets transmitted by the specified module.

After enabling packet logging using the **start** keyword, you can optionally specify the **flash** keyword to copy the packet log in the system’s memory to the management module’s flash memory. The name of the packet log in the management module’s flash memory is pktlog.txt. For example, to copy a log of packets transmitted and received by the interface module installed in chassis slot 1 to the management module’s flash memory, enter the following command at the global CONFIG level of the CLI:

```
BigIron RX(config)# packet-logging 1 flash 0
```

**Syntax:** packet-logging <slot-number> flash <packet-direction>

For the <slot-number> parameter, you can specify 1 – 4 for BigIron RX-4, 1 – 8 for BigIron RX-8 or 1 – 16 for BigIron RX-16.

You must specify the direction of packets that you want logged:

- 0 – Logs packets transmitted and received by the specified module.
- 1 – Logs packets received by the specified module.
- 2 – Logs packets transmitted by the specified module.

For example, to disable packet logging for the interface module installed in chassis slot 1, enter the following command at the global CONFIG level of the CLI:

```
BigIron RX(config)# packet-logging 1 stop
```

**Syntax:** packet-logging <slot-number> stop

For the <slot-number> parameter, you can specify 1 – 4 for BigIron RX-4, 1 – 8 for BigIron RX-8 or 1 – 16 for BigIron RX-16.

Specify the **stop** keyword to stop packet logging.

---

### NOTE

When finished gathering packet logging information for debugging purposes, Brocade recommends disabling the generation of a packet log, which is CPU-intensive and can affect the performance of the management module.

---

## Displaying a packet log

You can use the following methods to display the contents of a packet log:

- You can use the **show packet-logging** command, which is discussed in this section.
- If you decided to write the log (pktlog.txt) to the management module flash memory, in addition to using the **show packet-logging** command, you can access and view the log using flash memory file management commands.

For example, to display a packet log for the interface module in chassis slot 1 that has been written to the system's memory, enter the following command at any CLI level:

```
BigIron RX# show packet-logging 1 memory
..Total 31 packet records...
-----
--> TX
(Assist Header 0x11f: ver-0, priority-0, pkt_type-ARP packet)
(Foundry Header: fid-0x82, priority-3, sac-0, monitor-0, ipc_flag-0x1f,
reserved-0, pri_tagged-0, multicast_vid-0, protocol_type-0x2, us-0, brd-0,
dav-0, sav-0, dpv-0, sv-0, error-0, txa-0, sas-0, tagged-0, offset-16,
vlan_prio-0, cfi- 0, vlan_id-1)

011f0082 cf820010 000107c0 0060800b 020000e0 52ealf00 000cdb80 32820806
00010800 06040002 000cdb80 32820101 010100e0 52ealf00 01010102 5204ab10
-----
--> RX
(Assist Header 0x0: ver-0, priority-0, pkt_type-IP packet)
(LP2MP_ALT_FDRY_HDR 10 bytes: data-8 bytes, source_port-130,
pkt_data_offset-30, virtual_src_int-130)
0000bfff cf808810 00012087 80824de9 4001000c db803282 00e052ea 1f000800
4500002c 28e40000 40014de9 01010102 01010101 08003916 abcd0001 61626364
-----
==> TX
(Assist Header 0xf: ver-0, priority-0, pkt_type-IP packet)
(Foundry Header: fid-0x82, priority-3, sac-0, monitor-0, ipc_flag-0x1f,
reserved-0, pri_tagged-0, multicast_vid-0, protocol_type-0x1, us-0, brd-0,
dav-0, sav-0, dpv-0, sv-0, error-0, txa-0, sas-1, tagged-0, offset-16,
vlan_prio-0, cfi- 0, vlan_id-1)
000f0082 cf810090 000107c0 004c800b 020000e0 52ealf00 000cdb80 32820800
4500002c 86a20000 4001f02a 01010101 01010102 00004116 abcd0001 61626364
-----
...
```

**Syntax:** show packet-logging <slot-number> memory | flash pktlog.txt

For the <slot-number> parameter, you can specify 1 – 4 for BigIron RX-4, 1 – 8 for BigIron RX-8 or 1 – 16 for BigIron RX-16.

The **memory** | **flash pktlog.txt** keyword specifies that the packet log is written to the system's memory or to a file (pktlog.txt) written to the system's flash memory.

The display shows the following information:

**TABLE 23** Packet log fields

This field...	Displays...
...Total <number> packet records...	The total number of packets recorded in the packet log for a specified module.
TX or RX	TX indicates the packet was transmitted by the module, while RX indicates the packet was received by the module.
Assist Header <number>	A Brocade header associated with the packet
pkt_type	The packet type, which can be one of the following: <ul style="list-style-type: none"> <li>• IP – An IP packet</li> <li>• ARP – An ARP packet</li> <li>• STP – An STP packet</li> <li>• TCP – A TCP packet</li> <li>• UDP – A UDP packet</li> <li>• IPC packet – An interprocessor communication packet</li> <li>• ITC packet – An intertask communication packet</li> </ul>
<hexadecimal numbers>	The contents of the packet

## Removing MAC address entries

You can remove learned MAC address entries from the BigIron RX Series system's MAC address table. You can remove the following:

- All MAC address entries
- All MAC address entries for a specified interface module
- All MAC address entries for a specified Ethernet port
- All MAC address entries for a specified VLAN
- A specified MAC address entry in all VLANs

For example, to remove entries for the MAC address 000d.cb80.00d in all VLANs, enter the following command at the Privileged EXEC level of the CLI:

```
BigIron RX# clear mac-address 000d.cb80.00d0
```

**Syntax:** clear mac-address <mac-address> | ethernet <slot>/<port> | module <slot> | vlan <number>

If you enter the **clear mac-address** command without any parameters, the software removes all MAC entries.

Use the <mac-address> parameter to remove a specified MAC address from all VLANs. Specify the MAC address in the following format: HHHH.HHHH.HHHH.

Use the **ethernet** <slot>/<port> parameter to remove all MAC addresses for a specified Ethernet port. For the <slot> parameter, enter the number of the chassis slot in which the Ethernet interface module is installed. For the <port> parameter, enter the Ethernet port for which to remove all MAC addresses.

Use the **module** <slot> parameter to remove all MAC addresses for an interface module in a specified chassis slot.

Use the **vlan** <number> parameter to remove all MAC addresses for a specified VLAN.

## 5 Removing MAC address entries



# Maintaining a BigIron RX Series Switch

---

## In this chapter

- Replacing a management module ..... 137
- Replacing an interface module. .... 139
- Replacing a switch fabric module. .... 143
- Replacing a fiber-optic transceiver. .... 145
- Replacing a power supply ..... 147
- Replacing cooling system components ..... 150

## Replacing a management module



### **DANGER**

*The procedures in this manual are for qualified service personnel.*

This chapter provides a recommended hardware maintenance schedule for a BigIron RX Series switch. Procedures on how to replace the modules, AC power supply, and fan are also covered.

### **NOTE**

The BigIron RX Series management, interface, and switch fabric modules are dedicated, which means that you must install them in the BigIron RX Series chassis only. If you attempt to install the BigIron RX Series modules in another Brocade chassis or a module intended for another Brocade chassis in the BigIron RX Series chassis, the chassis and modules will not function properly.

You can remove a management module and replace it with a new one while the BigIron RX Series chassis is powered on and running.

### **NOTE**

The BigIron RX Series management module is dedicated, which means that you must install it in the BigIron RX Series chassis only. If you attempt to install the BigIron RX Series management module in another Brocade chassis or a management module intended for another Brocade chassis in the BigIron RX Series chassis, the chassis and module will not function properly.



### **CAUTION**

*If hot removing or inserting a module, please allow a minimum of two seconds after a module (or power supply or fan tray) has been removed before inserting a module in the same slot.*

---

**NOTE**

When a management switches over from active (remove active) to standby, it will send out the syslog messages or traps such as PSU failure or LP/SNM removal.

---

This section provides information about the following tasks:

- Removing a management module
- Installing a new management module

### Removing a management module

You can remove a management module while the BigIron RX Series chassis is powered on and running.

---

**NOTE**

Before removing and replacing an active or standby management module, you need to understand how these actions affect management module redundancy.

---

Before removing a management module from the BigIron RX Series chassis, have the following on hand:

- An ESD wrist strap with a plug for connection to the ESD connector on the BigIron RX Series chassis.

**DANGER**

*For safety reasons, the ESD wrist strap should contain a 1 meg ohm series resistor.*

---

- A large flat-head screwdriver.

Follow the steps given below to remove a management module from the BigIron RX Series chassis.

1. Put on the ESD wrist strap and ground yourself by inserting the plug into the ESD connector located on the chassis front.
2. Using the flathead screwdriver if necessary, loosen the two screws on the ends of the module.
3. Pull the card ejectors towards you, and away from the module front panel. This action unseats the module from the backplane.
4. Pull the module out of the chassis, and place in an anti-static bag for storage if desired.
5. Install a new module in the slot. For information about performing this task, refer to [“Installing a new management module”](#).

**CAUTION**

**If you do not install a module in a slot, you must keep the slot blank in place. If you run the chassis with an uncovered slot, the system may overheat.**

---

## Installing a new management module

You can install a management module while the BigIron RX Series chassis is powered on and running.

---

### NOTE

The BigIron RX Series management module is dedicated, which means that you must install it in the BigIron RX Series chassis only. If you attempt to install the BigIron RX Series management module in another Brocade chassis or a management module intended for another Brocade chassis in the BigIron RX Series chassis, the chassis and module will not function properly.

---

Before installing a module into the BigIron RX Series chassis, have the following on hand:

- A new management module, which you can order from Brocade.
- An ESD wrist strap with a plug for connection to the ESD connector on the BigIron RX Series chassis.



### DANGER

*For safety reasons, the ESD wrist strap should contain a 1 meg ohm series resistor.*

---

- A large flat-head screwdriver.

Follow the steps given below to install a new management module in the BigIron RX Series chassis.

1. Put on the ESD wrist strap and ground yourself by inserting the plug into the ESD connector located in the upper right corner of the chassis front.
2. Remove the module from its packaging.
3. Insert the module into the chassis slot, and slide the card along the card guide until the ejectors on either side of the module move close to the module front panel.
4. Push the ejectors even closer until they are flush with the module front panel. This action will fully seat the module in the backplane.
5. Tighten the two screws at either end of the module front panel by pushing them in and turning them clockwise. If desired, tighten the screws further using the flat-head screwdriver.

## Replacing an interface module

You can remove an interface module and replace it with a new one while the BigIron RX Series chassis is powered on and running.

---

### NOTE

A BigIron RX Series interface module is dedicated, which means that you must install it in the BigIron RX Series chassis only. If you attempt to install a BigIron RX Series interface module in another Brocade chassis or an interface module intended for another Brocade chassis in the BigIron RX Series chassis, the chassis and interface module may not function properly.

---

## 6 Replacing an interface module



### CAUTION

**If hot removing or inserting a module, please allow a minimum of two seconds after a module (or power supply or fan tray) has been removed before inserting a module in the same slot.**

This section provides information about the following tasks:

- Removing an interface module
- Installing a new interface module

## Removing an interface module

You can remove an interface module while the BigIron RX Series chassis is powered on and running.

Before removing an interface module from the BigIron RX Series chassis, you must disable the module, which prevents the remaining interface modules in the chassis from dropping user packets.

To perform this task, you must have the following on hand:

- An ESD wrist strap with a plug for connection to the ESD connector on the BigIron RX Series chassis.



### DANGER

***For safety reasons, the ESD wrist strap should contain a 1 meg ohm series resistor.***

- A large flat-head screwdriver.

Follow the steps given below to remove an interface module from the BigIron RX Series chassis.

1. Disable the module by entering the **power-off lp** <slot-number> command at the Privileged EXEC level of the CLI. For the <slot-number> parameter, specify 1 – 4 for BigIron RX-4, 1 – 8 for BigIron RX-8 or 1 – 16 for BigIron RX-16.
2. Put on the ESD wrist strap and ground yourself by inserting the plug into the ESD connector located in the upper right corner of the chassis front.
3. Using the flathead screwdriver if necessary, loosen the two screws on the ends of the module.
4. Pull the card ejectors towards you, and away from the module front panel. This action unseats the module from the backplane.
5. Pull the module out of the chassis, and place in an anti-static bag for storage if desired.
6. Install a new module in the slot. For information about performing this task, refer to [“Installing a new interface module”](#).



### CAUTION

**If you do not install a module in a slot, you must keep the slot blank in place. If you run the chassis with an uncovered slot, the system may overheat.**

## Installing a new interface module

You can install a new interface module while the BigIron RX Series chassis is powered on and running.

---

### NOTE

A BigIron RX Series interface module is dedicated, which means that you must install it in a BigIron RX Series chassis only. If you attempt to install a BigIron RX Series interface module in another Brocade chassis or an interface module intended for another Brocade chassis in a BigIron RX Series chassis, the chassis and interface module will not function properly.

---

Before installing one of these modules into the BigIron RX Series chassis, have the following on hand:

- A new interface module, which you can order from Brocade.
- An ESD wrist strap with a plug for connection to the ESD connector on the BigIron RX Series chassis.



### DANGER

***For safety reasons, the ESD wrist strap should contain a 1 meg ohm series resistor.***

---

- A large flat-head screwdriver.

Follow the steps given below to install a new interface module in the BigIron RX Series chassis

1. Put on the ESD wrist strap and ground yourself by inserting the plug into the ESD connector located in the upper right corner of the chassis front.
2. Remove the module from its packaging.
3. Insert the module into the chassis slot, and slide the card along the card guide until the ejectors on either side of the module move close to the module front panel.
4. Push the ejectors in the directions shown in [Figure 74](#) until they are flush with the module front panel. This action will fully seat the module in the backplane.
5. Tighten the two screws at either end of the module front panel by pushing them in and turning them clockwise. If desired, tighten the screws further using the flat-head screwdriver.
6. Go to config mode and set the module for interactive mode
7. `BigIron RX(config)# lp boot system interactive <slot number>`
8. Insert the new module (module should boot to interactive mode)
9. Load all required images for the line module that match the current version loaded on the chassis

For example:

```
copy tftp lp <ip-addr> rlb02200k.bin monitor copy-boot <slot number>
copy tftp lp <ip-addr> rlp02200k.bin primary <slot number>
```

10. Go to config mode and turn off the module for interactive mode

```
BigIron RX(config)# no lp boot system interactive <slot number>
```

11. Exit config mode and reboot the module

## 6 Replacing an interface module

```
BigIron RX# power-off lp <slot number>  
BigIron RX# power-on lp <slot number>
```

**FIGURE 73** Installing a module in a BigIron RX-4 chassis

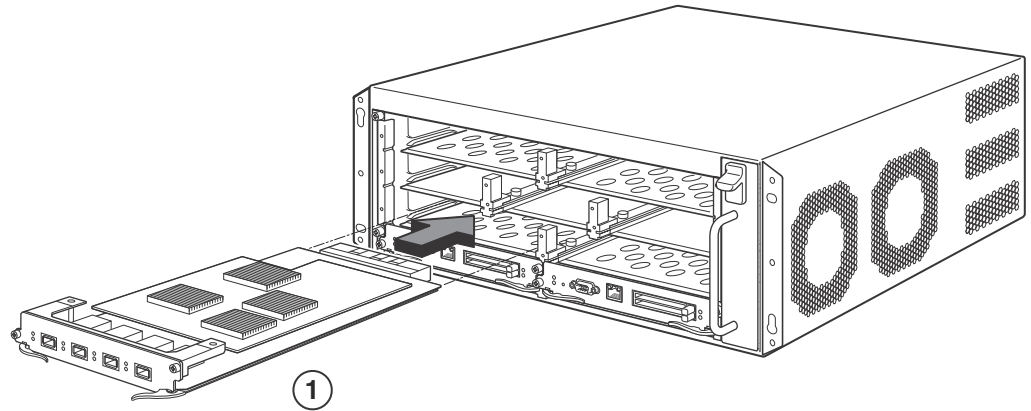

1 Interface module

**FIGURE 74** Installing a module in a BigIron RX-8 chassis

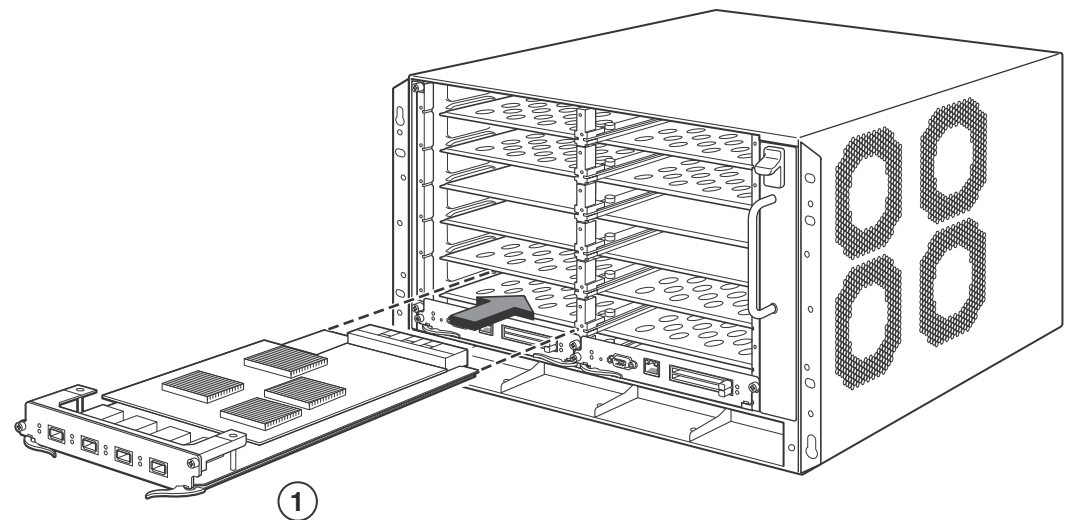

1 Interface module

FIGURE 75 Installing a module in a BigIron RX-16 chassis

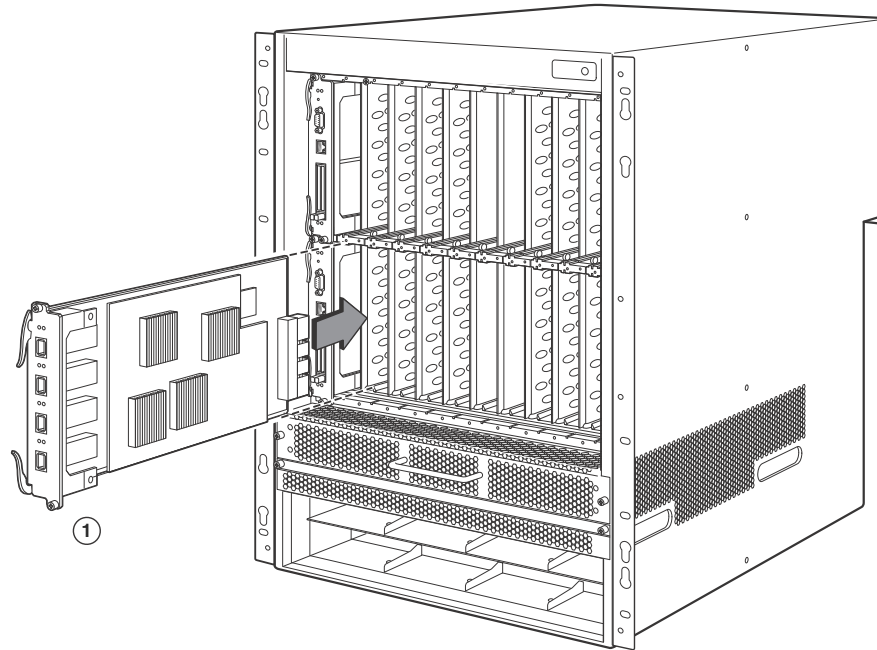

1 Interface module

## Replacing a switch fabric module

You can remove a switch fabric module while it is powered on and running and replace it with a new one.

---

### NOTE

A BigIron RX Series switch fabric module is dedicated, which means that it functions properly in the BigIron RX Series chassis only. If you attempt to install a BigIron RX Series switch fabric module in another Brocade chassis or a switch fabric module intended for another Brocade chassis in a BigIron RX Series chassis, the chassis and switch fabric module will not function properly.

---



### CAUTION

**If hot removing or inserting a module, please allow a minimum of two seconds after a module (or power supply or fan tray) has been removed before inserting a module in the same slot.**

---

This section provides information about the following tasks:

- Removing a switch fabric module
- Installing a new switch fabric module

## Removing a switch fabric module

For a graceful shutdown of the links, Brocade recommends that you disable the switch fabric module before removing it from the BigIron RX Series chassis by following the instructions below.

Before removing a switch fabric module from the BigIron RX Series chassis, have the following on hand:

- An ESD wrist strap with a plug for connection to the ESD connector on the BigIron RX Series chassis



### **DANGER**

***For safety reasons, the ESD wrist strap should contain a 1 meg ohm series resistor.***

- A large flat-head screwdriver

Follow the steps given below to remove a switch fabric module from the BigIron RX Series chassis.

1. Disable the module by entering the **power-off snm** <slot-number> command at the Privileged EXEC level of the CLI. For the <slot-number> parameter, specify 1 - 3 for BigIron RX-4, 1 - 3 for BigIron RX-8, 1 - 4 for BigIron RX-16, or 1 - 8 for BigIron RX-32.
2. Put on the ESD wrist strap and ground yourself by inserting the plug into the ESD connector located in the upper right corner of the chassis front.
3. Using the flathead screwdriver if necessary, loosen the two screws on the ends of the module.
4. Pull the card ejectors towards you, and away from the module front panel. This action unseats the module from the backplane.
5. Pull the module out of the chassis, and place in an anti-static bag for storage if desired.
6. Install a new switch fabric module in the slot. For information about performing this task, refer to ["Installing a new switch fabric module"](#) on page 144.

## Installing a new switch fabric module

The switch fabric modules on the BigIron RX Series switches are hot-swappable. This means that you can install a new switch fabric module without powering off the BigIron RX Series chassis.

---

### **NOTE**

A BigIron RX Series switch fabric module is dedicated, which means that it functions properly in the BigIron RX Series chassis only. If you attempt to install a BigIron RX Series switch fabric module in another Brocade chassis or a switch fabric module intended for another Brocade chassis in the BigIron RX Series chassis, the chassis and switch fabric module will not function properly.

---

Before installing a new switch fabric module into the BigIron RX Series chassis, have the following on hand:

- A new switch fabric module, which you can order from Brocade



- An ESD wrist strap with a plug for connection to the ESD connector on the BigIron RX Series chassis

**DANGER**

***For safety reasons, the ESD wrist strap should contain a 1 meg ohm series resistor.***

- A large flat-head screwdriver

Follow the steps given below to install a new switch fabric module in a BigIron RX Series chassis.

1. Put on the ESD wrist strap and ground yourself by inserting the plug into an ESD connector located on the chassis front.
2. Remove the new module from its packaging.
3. Insert the module into the chassis slot, and slide the card along the card guide until the ejectors on either side of the module move close to the module front panel.
4. Push the ejectors even closer until they are flush with the module front panel. This action will fully seat the module in the backplane.
5. Tighten the two screws at either end of the module front panel by pushing them in and turning them clockwise. Then, tighten the screws further using the flat-head screwdriver.

## Replacing a fiber-optic transceiver

You can remove an SFP or XFP transceiver from a port and replace it with a new one while the BigIron RX Series chassis is powered on and running.

This section provides information about the following tasks:

- Removing the fiber-optic transceiver
- Installing a new fiber-optic transceiver
- Cabling a fiber-optic transceiver

### Removing a fiber-optic transceiver

You can remove a SFP (also called a mini-GBIC) or an XFP transceiver from a port while the BigIron RX Series chassis is powered on and running.

Before removing a fiber-optic transceiver, have the following on hand:

- An ESD wrist strap with a plug for connection to the ESD connector on the BigIron RX Series chassis

**DANGER**

***For safety reasons, the ESD wrist strap should contain a 1 meg ohm series resistor.***

- The protective covering that you removed from the fiber-optic transceiver port when you initially installed the module
- A small flathead screwdriver

## 6 Replacing a fiber-optic transceiver

Follow the steps given below to remove a fiber-optic transceiver from a 10 Gigabit Ethernet port.

1. Put on the ESD wrist strap and ground yourself by inserting the plug into the ESD connector located in the upper right corner of the chassis front.
2. Disconnect the two fiber cable connectors from the port connectors.
3. Insert the protective covering into the port connectors.
4. Pull down the latch on the front of the transceiver.
5. Pull the transceiver out of the port, and place it in an anti-static bag for storage, if desired.
6. Install a new fiber-optic transceiver in the port. For information about performing this task, refer to [“Installing a new fiber-optic transceiver”](#) next.

### Installing a new fiber-optic transceiver

You can install a new fiber-optic module (SFP or XFP transceiver) in each Gigabit Ethernet and 10 Gigabit Ethernet port while the BigIron RX Series chassis is powered on and running.

Before installing one of these modules into the port, have the following on hand:

- A new fiber-optic module, which you can order from Brocade
- An ESD wrist strap with a plug for connection to the ESD connector on the BigIron RX Series chassis



#### **DANGER**

***For safety reasons, the ESD wrist strap should contain a 1 meg ohm series resistor.***

Follow the steps given below to install a fiber-optic module into a 10 Gigabit Ethernet port.

1. Put on the ESD wrist strap and ground yourself by inserting the plug into the ESD connector located in the upper right corner of the chassis front.
2. Remove the new module from its protective packaging.
3. Gently insert the fiber-optic module into the port until the module clicks into place. The fiber-optic modules are keyed to prevent incorrect insertion.

### Cabling a fiber-optic transceiver

Follow the steps given below to cable a fiber-optic module.

1. Remove the protective covering from the fiber-optic port connectors and store the covering for future use.
2. Before cabling a fiber-optic module, Brocade strongly recommends cleaning the cable connectors and the port connectors. For more information, refer to [“Cleaning fiber optic modules”](#) on page 108.
3. Gently insert the two cable connectors (a tab on each connector should face upward) into the port connectors until the tabs lock into place.
4. Observe the link and active LEDs to determine if the network connections are functioning properly. For more information about the LED indicators, refer to [Table 16](#) on page 109.

## Replacing a power supply

You can replace a power supply while the BigIron RX Series chassis is powered on and running. The power supplies are located in slots along the bottom of the BigIron RX Series chassis.



### **CAUTION**

**If hot removing or inserting a module, please allow a minimum of 2 seconds after a module (or power supply or fan tray) has been removed before inserting a module in the same slot.**

This section provides information about the following topics:

- Determining which AC or DC power supply has failed, if necessary
- Replacing a AC or DC power supply

### Determining which power supply failed

To determine which power supply has failed, enter the following command at any CLI command prompt:

```
BigIron RX# show chassis
```

This command displays status information for the fans and power supplies, and temperature readings for various components in the chassis. The power supplies are numbered in the display.

If the display indicates “Installed (Failed)” for any of the slots, the power supply installed in that particular slot has failed or is not properly installed.

### Replacing a power supply

To replace a power supply, you need the following:

- A new power supply (AC or DC), which you can order from Brocade
- A small flathead or Phillips screwdriver (BigIron RX-4 only)



### **DANGER**

***The power supplies are hot swappable, which means they can be removed and replaced while the BigIron RX Series chassis is powered on and running. However, Brocade recommends that you disconnect the power supply from its power source before removing and replacing the***

## 6 Replacing a power supply

*supply. The BigIron RX Series chassis can be running while a power supply is being removed and replaced, but the power supply itself should not be connected to a power source. Otherwise, you could be injured or the power supply or other parts of the device could be damaged.*

---



### **DANGER**

---

*The front panel of an power supplies include a handle that locks the power supply in the chassis. This handle is a locking mechanism only and should not be used to lift and carry the power supply. You may sustain physical injury or harm if you attempt to lift and carry a power supply using the locking handle.*

---

Follow the steps given below to replace a power supply.

1. Disconnect the power supply from its power source.
2. Disconnect the power cables from the power supply.
3. In the BigIron RX-4 use the screwdriver to loosen the two screws on both sides of the power supply front panel. Then pull the ejectors forward until the power supply is pulled from its connection to the backplane.
4. In the BigIron RX-8, BigIron RX-16, pull up on the plunger in front of the face plate and pull on the handle toward you until the power supply is released.
5. On the BigIron RX-32, make sure the captured screw underneath the latch handle on the power supply faceplate is loose. Pull down on the latch handle and curl your fingers over the handle. Pull the handle straight out toward you to unlock the power supply from its position in the chassis. Refer to [Figure 76](#)

FIGURE 76 Removing and replacing a BigIron RX-32 power supply

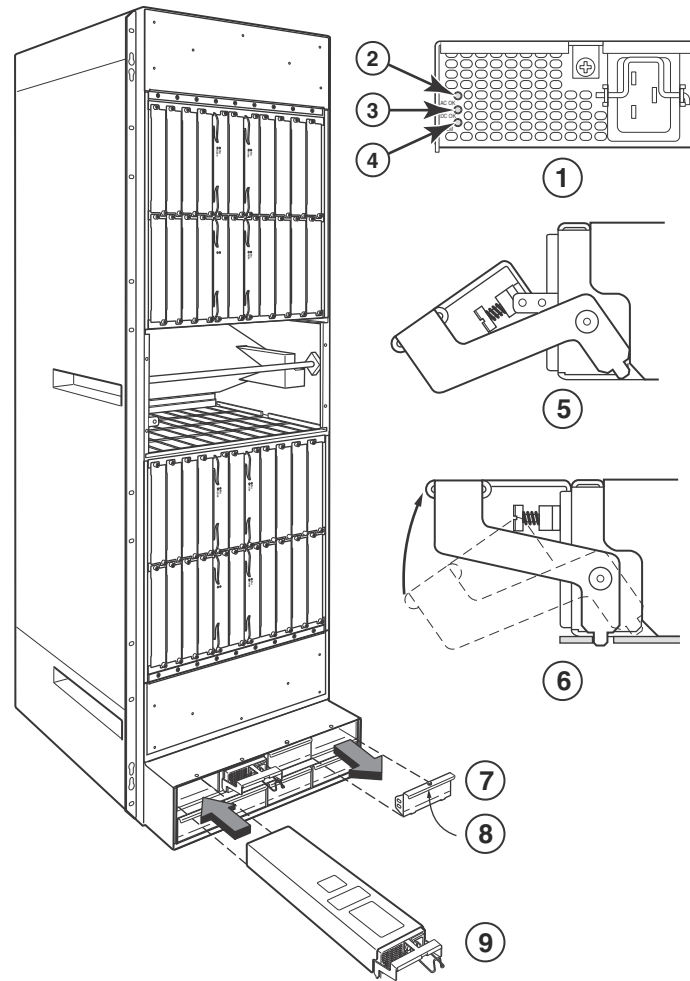

- |   |                         |   |                                |
|---|-------------------------|---|--------------------------------|
| 1 | Power supply indicators | 6 | Latch handle locked            |
| 2 | AC OK                   | 7 | Power supply blank cover       |
| 3 | DC OK                   | 8 | Pull down on plunger to remove |
| 4 | ALM                     | 9 | Power supply                   |
| 5 | Latch handle open       |   |                                |

6. Continue to pull the power supply until it is removed from the chassis.
7. Insert the new power supply into the empty power supply slot, using the guides provided on either side of the slot.



**CAUTION**

Carefully follow the mechanical guides on each side of the power supply slot and make sure the power supply is properly inserted in the guides. Never insert the power supply upside down.

## 6 Replacing cooling system components

8. After the power supply is fully inserted, push the power supply front panel toward the back of the chassis until the power supply is fully seated.
9. For the BigIron RX-32, gently pull the handle on the power supply front panel upward and toward the top of the power supply front panel. This action locks the power supply in place.
10. In the BigIron RX-4, use the screwdriver to secure the two screws on either side of the power supply front panel.
11. Connect the AC power cord or DC power lugs to the power supply front panel.
12. Connect the power to its AC or DC source.
13. Observe the LEDs on the power supply front panel:
  - For a DC Supply, the DC IN and DC OUT LEDs should be green which indicates the power supply is providing power to the chassis components.
  - For an AC Supply, the AC OK and DC OK LEDs should be green which indicates the power supply is providing power to the chassis components.
  - If the ALM LED is On (Amber) then the power supply has failed.

For information about troubleshooting this problem, refer to [Table 13](#) on page 81.

## Replacing cooling system components

The BigIron RX Series cooling systems are described in the following sections:

- [“Replacing fan assemblies in the BigIron RX- 32”](#) on page 150
- [“Replacing fan assemblies in the BigIron RX-16”](#) on page 153
- [“Replacing the fan assembly in the BigIron RX-4 and BigIron RX-8”](#) on page 155

You can replace a fan or a fan control module while the BigIron RX Series chassis is powered on and running. The fans and fan control modules are located on rear panel of the BigIron RX Series chassis.



### **CAUTION**

**If hot removing or inserting a module, please allow a minimum of 2 seconds after a module (or power supply or fan tray) has been removed before inserting a module in the same slot.**

The following sections provide more information about replacing these components.

## Replacing fan assemblies in the BigIron RX- 32



### **CAUTION**

**Removal of rear fan modules allows access to buss bars and backplane. Avoid connect with these parts. There is hazardous energy level at these locations.**

The BigIron RX-32 has ten fan assemblies that pull air out. They are accessible from the rear of the chassis. They are numbered as indicated in [Figure 77](#).

You can remove and replace a fan assembly while the BigIron RX-32 chassis is powered on and running.

**CAUTION**

To avoid overheating of the BigIron RX-32 chassis, remove only one fan assembly at a time, and replace it promptly. Wait for the LED on the fan assembly being replaced to turn green before replacing another fan assembly. Do not remove all fans from the chassis at one time.

Before replacing a fan assembly, you need the following:

- A new fan assembly, which you can order from Brocade
- A small flathead screwdriver
- An ESD wrist strap with a plug for connection to the ESD connector on the front of the chassis.

**DANGER**

*For safety reasons, the ESD wrist strap should contain a 1 meg ohm series resistor.*

Follow the steps given below to replace a fan assembly.

1. Put on the ESD wrist strap and ground yourself by inserting the plug into the ESD connector on the chassis.
2. Using the flathead screwdriver, remove the screws that secure the fan assembly face plate on the rear of the chassis.
3. Remove the fan assembly from the chassis by grasping the handle on the face plate and pulling the fan assembly toward you as shown in [Figure 78](#). Pulling the fan assembly unseats the fan connector from a chassis connector.

**DANGER**

*The BigIron RX-32 fan assembly is heavy and will be off-balance as you remove it. Use both hands on the handle.*

**DANGER**

*Be careful not to insert your fingers into the fan while removing it from the chassis. The fan may still be spinning at a high speed.*

FIGURE 77 Removing a BigIron RX-32 fan assembly

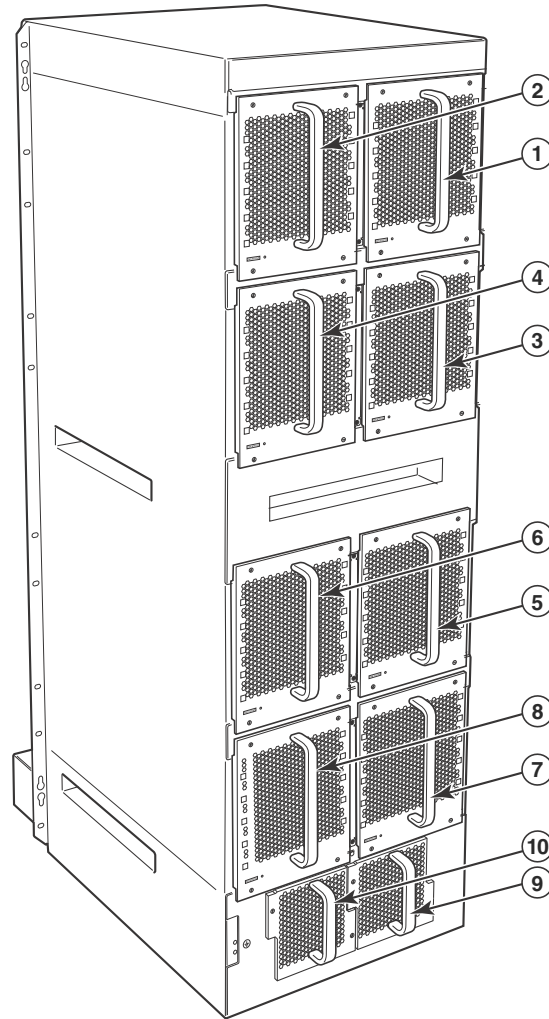

- |   |              |    |               |
|---|--------------|----|---------------|
| 1 | Fan module 1 | 6  | Fan module 6  |
| 2 | Fan module 2 | 7  | Fan module 7  |
| 3 | Fan module 3 | 8  | Fan module 8  |
| 4 | Fan module 4 | 9  | Fan module 9  |
| 5 | Fan module 5 | 10 | Fan module 10 |

4. Insert the new fan assembly into the fan slot and push the assembly in until the face plate is flush with the chassis. Pushing the fan assembly in seats the fan connector with the chassis connector.
5. Secure the fan assembly to the chassis by replacing and tightening the four screws on the card cage fan assemblies and the two screws on the power supply fan assemblies.
6. Check the fan status LED in the lower left corner of the face plate. It will be red momentarily when power is applied, then change to green when the fan comes up to speed.



7. Access the CLI, and enter the **show chassis** command to verify that the fan is operating normally.

## Replacing fan assemblies in the BigIron RX-16

The BigIron RX-16 has three fan assemblies: one accessible from the front of the chassis and two accessible from the rear. The front assembly pushes air into the chassis and the rear fans pull air out.

You can remove and replace a fan assembly while the BigIron RX-16 chassis is powered on and running.



### **CAUTION**

**To avoid overheating of the BigIron RX-16 chassis, remove only one fan assembly at a time, and replace it promptly. Do not remove all fans from the chassis at one time.**

To replace a fan, you need the following:

- A new fan assembly, which you can order from Brocade
- A small flathead screwdriver
- An ESD wrist strap with a plug for connection to the ESD connector on the BigIron RX Series chassis



### **DANGER**

**For safety reasons, the ESD wrist strap should contain a 1 meg ohm series resistor.**

## *Replacing the rear fan assemblies in the BigIron RX-16*

Follow the steps given below to replace a fan assembly.

1. Put on the ESD wrist strap and ground yourself by inserting the plug into the ESD connector.
2. Using the flathead screwdriver, loosen the four captive screws that secure the fan (marked “Fan A” or “Fan B”) to the chassis rear.
3. Remove the fan from the chassis by inserting your fingers underneath the fan enclosure and pulling the enclosure toward you as shown in [Figure 78](#). Pulling the enclosure unseats the fan connector from a chassis connector.



### **DANGER**

**Be careful not to insert your fingers into the fan while removing it from the chassis. The fan may still be spinning at a high speed.**

## 6 Replacing cooling system components

**FIGURE 78** Removing a BigIron RX-16 rear fan assembly

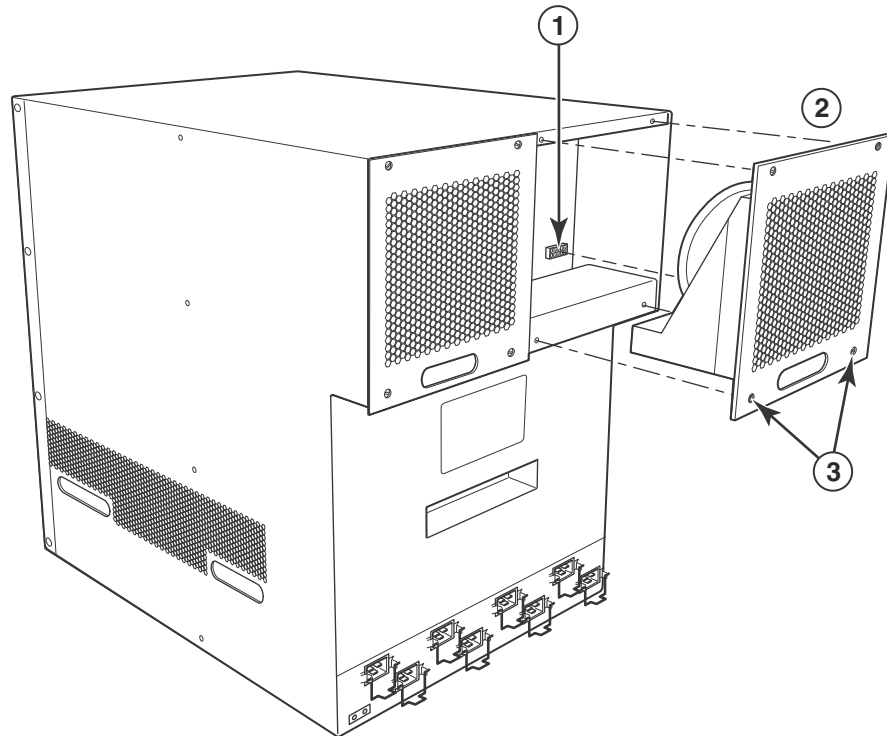

- 1 Power connector
- 2 Fan assembly

- 3 Captive screws

4. Insert the new fan into the fan slot and push the enclosure in until the face plate is flush with the chassis. Pushing the enclosure in seats the fan connector with the chassis connector.
5. Secure the fan to the chassis by tightening the four captive screws.
6. Access the CLI, and enter the **show chassis** command to verify that both fans are operating normally.

### ***Replacing the front fan assembly in the BigIron RX-16***

Follow the steps given below to replace a fan.

1. Put on the ESD wrist strap and ground yourself by inserting the plug into the ESD connector located in the upper right corner of the chassis rear.
2. Using the flathead screwdriver, loosen the four captive screws that secure the fan assembly to the chassis front.

3. Remove the fan assembly from the chassis by grabbing the handle on the fan assembly and pulling it toward you as shown in [Figure 79](#). Pulling the enclosure unseats the fan assembly connector from a chassis connector.

**DANGER**

*Be careful not to insert your fingers into the fan while removing it from the chassis. The fan may still be spinning at a high speed.*

**FIGURE 79** Removing a BigIron RX-16 front fan assembly

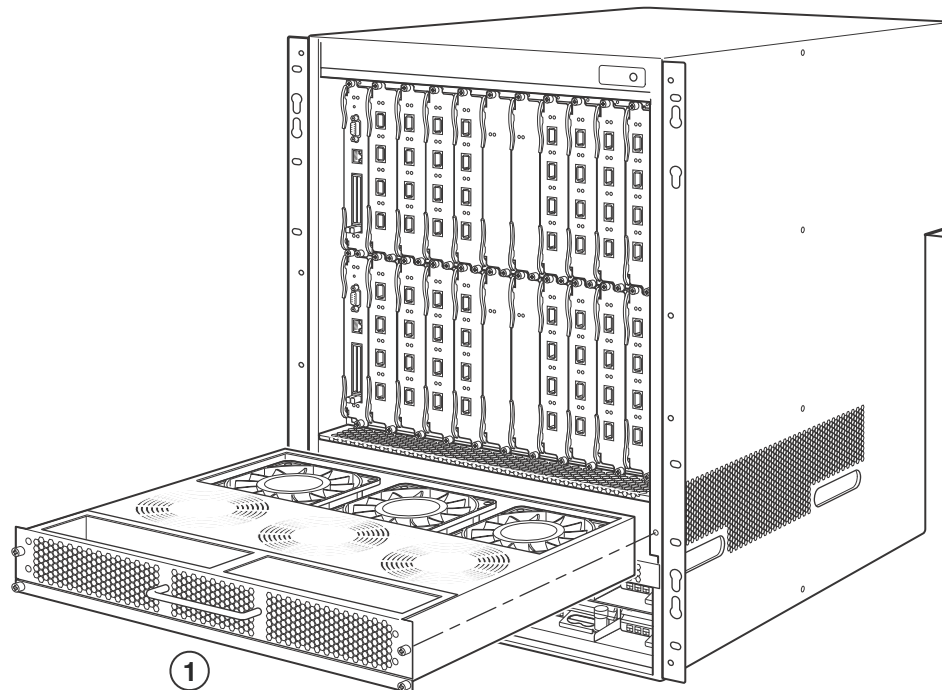

1. Fan assembly
4. Insert the new fan assembly into the fan slot and push the enclosure in until the face plate is flush with the chassis. Pushing the enclosure in seats the fan connector with the chassis connector.
5. Secure the fan to the chassis by tightening the four captive screws.
6. Access the CLI, and enter the **show chassis** command to verify that the fans are operating normally.

## Replacing the fan assembly in the BigIron RX-4 and BigIron RX-8

The BigIron RX-4 and BigIron RX-8 have a fan assembly accessible from the front of the chassis. The fan assembly pulls air out of the chassis.

## 6 Replacing cooling system components

---

### NOTE

If you did not remove the extra shipment screws from the BigIron RX-4 and BigIron RX-8 chassis during installation (refer to “[Removing BigIron RX-4 extra shipment screws](#)” on page 30), then you will not be able to remove the fan tray assembly. In this case, you will have to remove the BigIron RX-4 or BigIron RX-8 from the rack to remove the shipment screws.

---

You can remove and replace a fan assembly while the BigIron RX-4 and BigIron RX-8 chassis are powered on and running.

To replace a fan, you need the following:

- A new fan assembly, which you can order from Brocade
- An ESD wrist strap with a plug for connection to the ESD connector on the BigIron RX Series chassis



### DANGER

*For safety reasons, the ESD wrist strap should contain a 1 meg ohm series resistor.*

---

Follow the steps given below to replace a fan assembly in the BigIron RX-4 and BigIron RX-8.

1. Put on the ESD wrist strap and ground yourself by inserting the plug into the ESD connector located in the upper right corner of the chassis rear.
2. Push down on the latch release with your thumb.
3. Remove the fan assembly from the chassis by grabbing the handle on the fan assembly and pulling it toward you as shown in [Figure 80](#) and [Figure 81](#). Pulling the enclosure unseats the fan assembly connector from a chassis connector.



### DANGER

*Be careful not to insert your fingers into the fan while removing it from the chassis. The fan may still be spinning at a high speed.*

---

**FIGURE 80** Removing a fan from a BigIron RX-4 switch

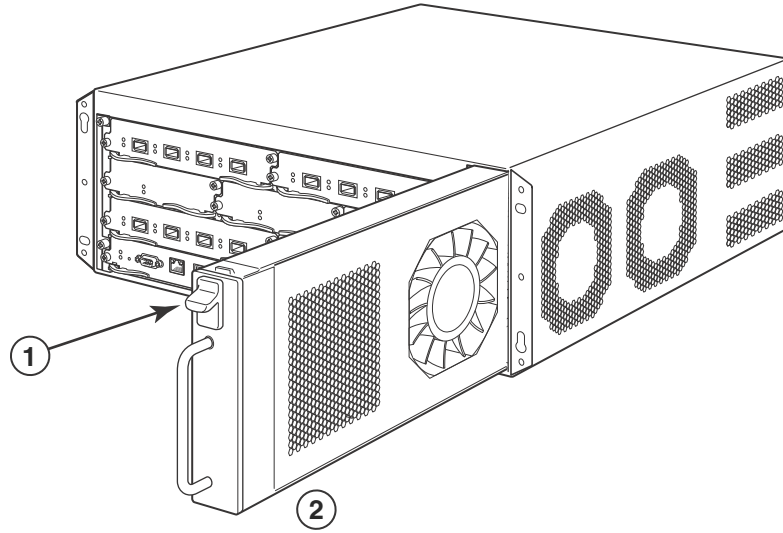

- 1 Latch release
- 2 Fan tray assembly

**FIGURE 81** Removing a fan from a BigIron RX-8 switch

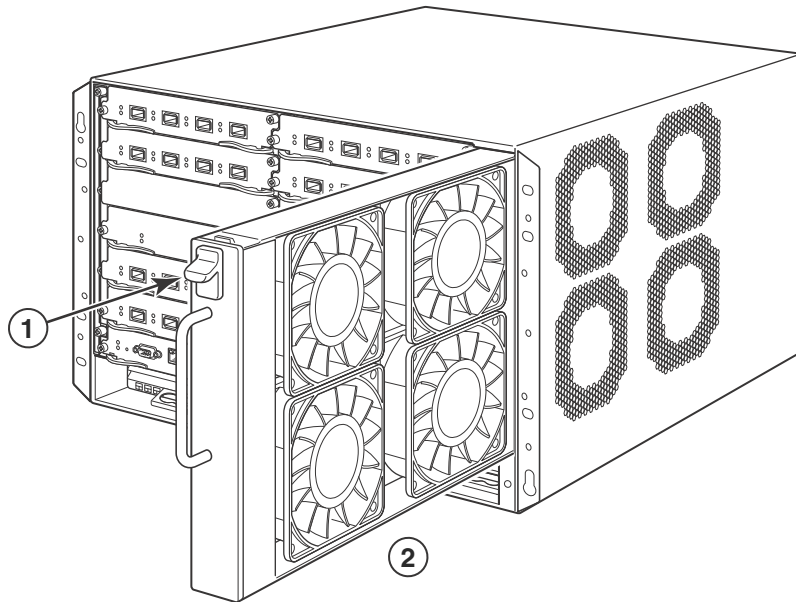

- 1 Latch release
- 2 Fan tray assembly

4. Insert the new fan assembly into the fan slot and push the enclosure in until the face plate is flush with the chassis. Pushing the enclosure in seats the fan connector with the chassis connector.
5. Secure the fan to the chassis by tightening the four captive screws.

## 6 Replacing cooling system components

6. Access the CLI, and enter the **show chassis** command to verify that the fans are operating normally.

### Replacing the air filters in a BigIron RX Series switch

Brocade recommends replacing the air filters in BigIron RX Series switches quarterly. Replacing the filters regularly prevents the accumulation of dust on module components.

You can replace the air filters while the BigIron RX Series chassis is powered and running. To perform this task, you need the following:

- A small Allen wrench
- Replacement air filters, which you can order from Brocade

Procedures for replacing the air filters are described in the following sections:

- [“Replacing the air filters in the BigIron RX-32”](#)
- [“Replacing the air filter in the BigIron RX-16”](#)
- [“Replacing the air filter in the BigIron RX-4 or BigIron RX-8”](#)

#### *Replacing the air filters in the BigIron RX-32*

The two air filters in the BigIron RX-32 chassis are located between the upper and lower card cages. Follow the steps given below to replace the filters.

---

**NOTE**

The air filter for the BigIron RX-32 chassis is marked with a directional arrow to indicate proper alignment for the direction of airflow in the chassis. The upper filter should be inserted with the arrow pointing up, and the lower filter should be inserted with the arrow pointing down

---

1. From the front of the chassis, remove the air inlet cover by unscrewing the four socket head screws with an Allen wrench, as shown in [Figure 82](#).

**FIGURE 82** BigIron RX-32 air inlet panel

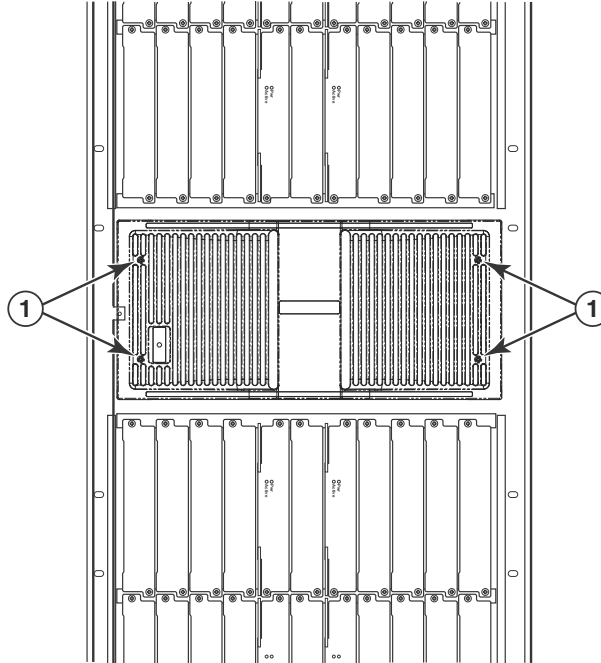

1. Captive screws
2. Remove the first filter by pulling it straight out, as shown in [Figure 83](#).
3. Insert a new filter, being careful that it aligns within the narrow channel.
4. Repeat steps 2-3 with the second filter.
5. Replace the air inlet cover and screw in the four captive screws until they are securely attached to the chassis.

## 6 Replacing cooling system components

**FIGURE 83** Air filter removal and replacement for BigIron RX-32

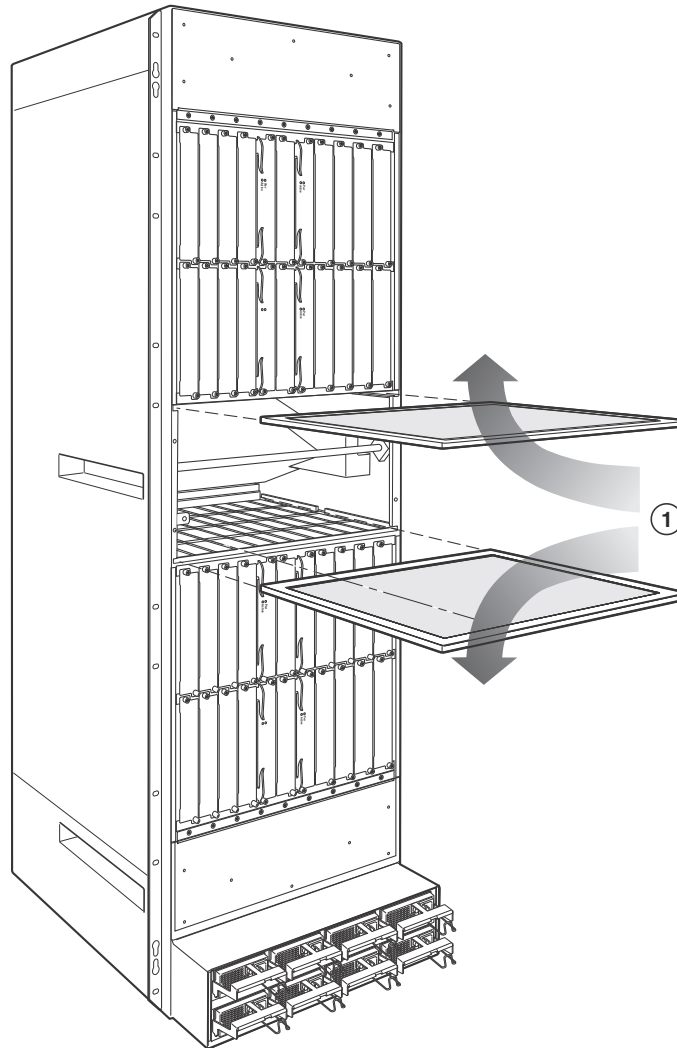

- 1 Direction of airflow in chassis

### ***Replacing the air filter in the BigIron RX-16***

Follow the steps given below to replace the air filter in the BigIron RX-16.

1. Loosen the two screws in the front of the filter retainer.
2. Pull the filter retainer away from the chassis as shown in [Figure 84](#).



There is a hook on the back of the retainer that is attached to the grab-strap. As you pull the retainer out, the filter is pulled along with it.

**FIGURE 84** Air filter removal and replacement for BigIron RX-16

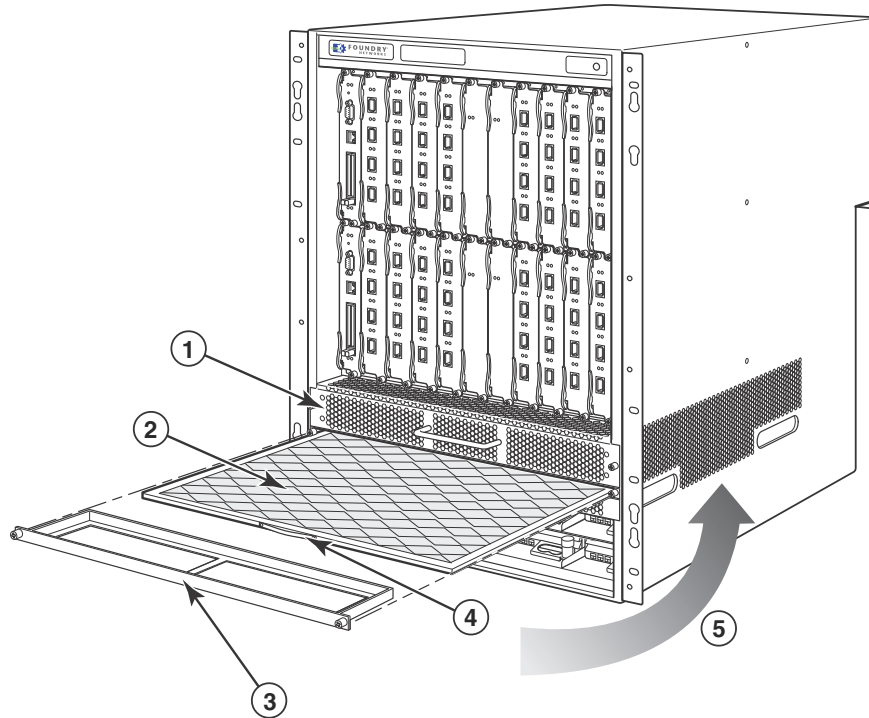

- |   |                 |   |                                 |
|---|-----------------|---|---------------------------------|
| 1 | Fan tray        | 4 | Filter grab strap               |
| 2 | Filter          | 5 | Direction of airflow in chassis |
| 3 | Filter retainer |   |                                 |

3. Attach the hook on the back of the filter retainer to the filter grab-strap.
4. Push the filter retainer into the chassis and tighten the two screws.

### ***Replacing the air filter in the BigIron RX-4 or BigIron RX-8***

Follow the steps given below to replace the air filter in the BigIron RX-4 or BigIron RX-8.

1. Loosen the two screws in the front of the filter retainer.
2. Pull the filter retainer away from the chassis as shown in [Figure 85](#) or [Figure 86](#).

## 6 Replacing cooling system components

**FIGURE 85** Air filter removal and replacement for BigIron RX-4

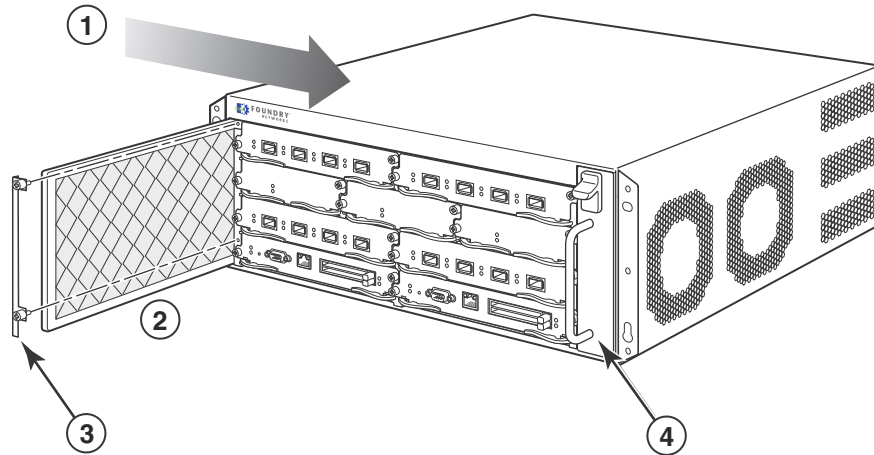

- |   |                                 |   |                 |
|---|---------------------------------|---|-----------------|
| 1 | Direction of airflow in chassis | 3 | Filter retainer |
| 2 | Filter                          | 4 | Fan trap        |

**FIGURE 86** Air filter removal and replacement for BigIron RX-8

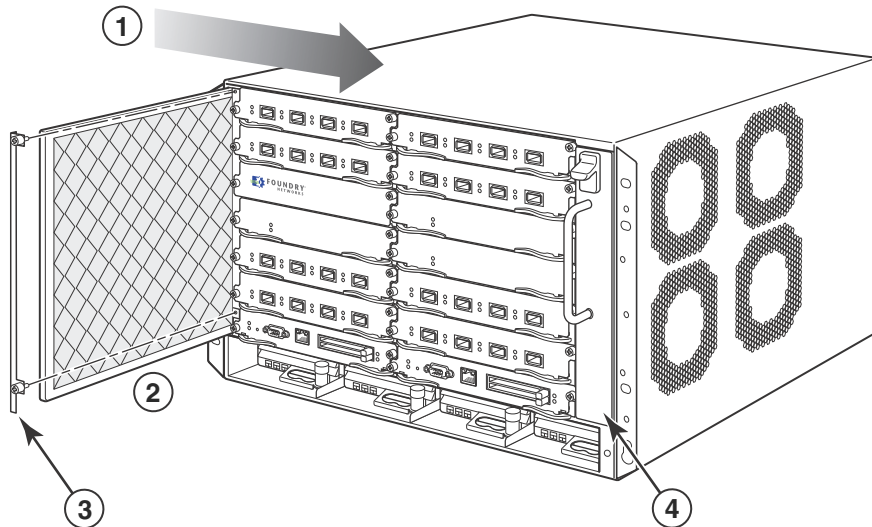

- |   |                                 |   |                 |
|---|---------------------------------|---|-----------------|
| 1 | Direction of airflow in chassis | 3 | Filter retainer |
| 2 | Filter                          | 4 | Fan trap        |

3. Pull the air filter out of the chassis and discard.
4. Insert the replacement air filter by sliding it along the metal guides.

The filter is marked with an arrow. The arrow indicates how the filter should be installed in regards to the direction of airflow in the chassis. Since air is pulled through the chassis, the arrow must point right towards the fan tray.

Push the filter retainer into the chassis and tighten the two screws.

# Upgrading Software Images and Configuration Files

## In this chapter

- Software images required. . . . . 163
- Software image naming conventions. . . . . 165
- Displaying flash memory and version information . . . . . 166
- Upgrading the BigIron RX Series software. . . . . 174
- Loading and saving configuration files . . . . . 189
- Dynamic configuration loading. . . . . 191
- Using SNMP to save and load configuration information. . . . . 194
- Erasing image and configuration files . . . . . 195
- File synchronization. . . . . 195
- Scheduling a system reload . . . . . 198
- Diagnostic error codes and remedies for TFTP transfers . . . . . 199

## Software images required

This chapter describes the software images required to operate a BigIron RX Series switch and how to load them on the switch. The images required are described in [Table 24](#).



### **DANGER**

*The procedures in this manual are for qualified service personnel*

**TABLE 24** Software image files

Module	Image type	Image name
Management Module	Boot and Monitor	rmb<xxxx>
	IronWare	rmpr<xxxx>
	FPGA	mbridge
Interface Module	Boot and Monitor	rlb<xxxx>
	IronWare	rlp<xxxx>

### **NOTE**

<xxxx> is a variable that refers to the release-specific information as described in "Software Image Naming Conventions". Specific contents of this field are determined by release and are available in the relevant release notes.

This section describes each of the software images required to operate a BigIron RX Series switch as described in Table 24. Also, Figure 87 illustrates how each of the files are stored on the management and interface modules.

FIGURE 87 Management and interface modules flash images

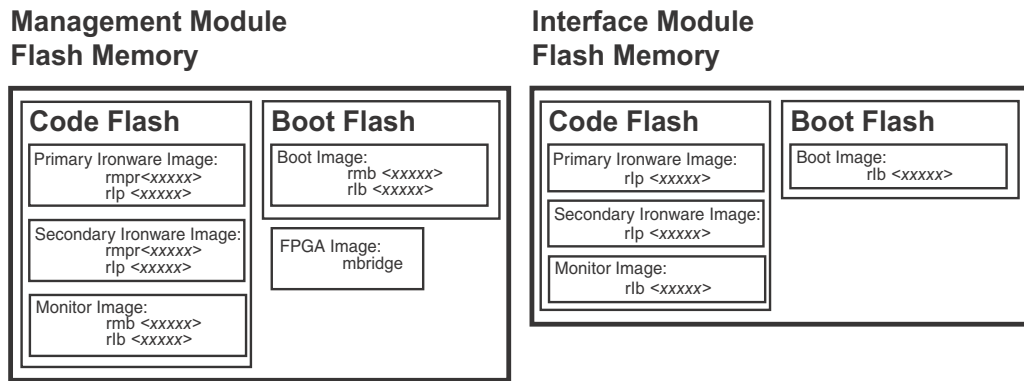

The software images are described in the following:

### *IronWare image*

An IronWare image, also known as the *software image*, contains the application software, the network protocols and features that define the characteristics of the device. IronWare images can be loaded in the Primary or Secondary location of Code Flash on the modules. IronWare images are named as described in Table 24. There is one IronWare image for the management module and another for the interface module.

---

#### NOTE

The IronWare image for interface modules is loaded on both the interface and management modules. The reason for this redundancy is to verify that the same image is loaded on all the interface modules. The management module does not run the interface module code, it only compares the code with the code on the other interface modules. If the code is not the same, the files are synchronized and updated to match the interface code on the management module.

---

### *Monitor image*

A Monitor image, also known as the *real time operating system*, allows hardware to run multiple, parallel, distributed functions. The Monitor Image delegates low-level functions to the smaller processor on each interface module. Monitor images are loaded in the Code Flash and Boot Flash on the interface and management modules. Monitor images are named as described in Table 24.

### *Boot image*

The Boot image, which is packaged with the Monitor image, contains initialization instructions for the hardware startup. Boot images are named as described in Table 24.

### *FPGA image*

The FPGA image is named "MBRIDGE" and serves as the interface between the management module and the backplane. It is loaded on the management module only.

### *Startup configuration file*

The Startup Configuration file contains a default configuration that is loaded at the factory and appended with commands for the user. It is loaded on the management module only.

## Software image naming conventions

This section describes the alpha-numeric scheme used to define the names of the image files used to operate a BigIron RX Series switch. [Figure 88](#) illustrates the structure of the image names and the paragraphs that follow describe what each of the fields in the image name represents.

**FIGURE 88** Software naming syntax

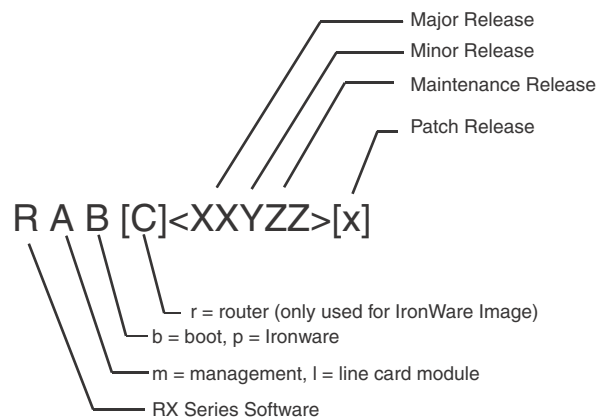

To identify the software image, the naming conventions encode a specific meaning for each of the variables in the following syntax:

**R** indicates the software image is used on BigIron RX Series switches.

**A** indicates the *module* type:

- If the value of A is **m**, the image supports a management module.
- If the value of A is **l**, the image supports an interface module.

**B** indicates the *software* type:

- If the value of B is **r**, the image contains management IronWare application software.
- If the value of B is **p**, the image contains interface IronWare application software.
- If the value of B is **b**, the image contains Boot-Monitor system software.

**C** is only used with IronWare management Images. it indicates:

- If the value of C is **r**, the image contains IronWare management application software.

*Release types*

XX contains the major release number, for example, 01 or 02.

Y contains the minor release number, for example, 1 or 2.

ZZ contains the maintenance release number, for example, 00 or 01.

x = is an optional field; it indicates the patch release, for example, c.

*Release number*

To be supported, a BigIron RX Series chassis must have a software version number <XXYZZ>x that is consistent across hardware modules and software types The following examples are the software images for the first release of BigIron RX Series switches:

- rmb023000—BigIron RX Series MP boot-monitor image
- rmr023000—BigIron RX Series MP image
- rlb023000—BigIron RX Series LP boot-monitor image
- rlp023000—BigIron RX Series LP IronWare image

## Displaying flash memory and version information

The IronWare image for the management module is loaded with the IronWare image for the interface module in the Primary location on the code flash.

The switch IronWare image for the management module is loaded with the IronWare image for the interface module in the Secondary location on the code flash.

The monitor image for the management module is loaded with the monitor image for the interface module in the Monitor file on the code flash.

The monitor image for the management module is also on the boot flash.

### Displaying flash information

You can display information concerning the contents of an BigIron RX Series switch using the **show flash** command as shown in the following:

```
BigIron RX#show flash
=====
Active Management Module (Top Slot)
Code Flash - Type MT28F128J3, Size 32 MB
  o IronWare Image (Primary)
    Version 2.5.0T143, Size 4141014 bytes, Check Sum a3c8
    Compiled on Oct 19 2007 at 23:42:24 labeled as rmpr02500

  o IronWare Image (Secondary)
    Version 2.5.0T143, Size 4137876 bytes, Check Sum 662e
    Compiled on Oct 15 2007 at 14:32:00 labeled as rmpr02500

  o LP Kernel Image (Monitor for LP Image Type 0)
    Version 2.5.0T155, Size 285248 bytes, Check Sum 5643
    Compiled on Oct 19 2007 at 23:08:32 labeled as rlb02500
```

- o LP IronWare Image (Primary for LP Image Type 0)  
Version 2.5.0T157, Size 2000853 bytes, Check Sum 1e45  
Compiled on Oct 20 2007 at 00:05:04 labeled as rlp02500
- o LP IronWare Image (Secondary for LP Image Type 0)  
Version 2.5.0T157, Size 1999406 bytes, Check Sum 04f4  
Compiled on Oct 10 2007 at 17:15:40 labeled as rlp02500
- o Boot-Monitor Image  
Version 2.5.0T145, Size 420184 bytes, Check Sum 5111  
Compiled on Oct 19 2007 at 23:09:14 labeled as rmb02500
- o Startup Configuration  
Size 4344 bytes, Check Sum 26b1  
Modified on 00:15:48 GMT+00 Tue Oct 23 2007

Boot Flash - Type AM29LV040B, Size 512 KB

- o Boot-Monitor Image  
Version 2.5.0T145, Size 420184 bytes, Check Sum 5111  
Compiled on Oct 19 2007 at 23:09:14 labeled as rmb02500

~~~~~  
Standby Management Module (Bottom Slot)

Code Flash: Type MT28F128J3, Size 32 MB

- o IronWare Image (Primary)  
Version 2.5.0T143, Size 4141014 bytes, Check Sum a3c8  
Compiled on Oct 19 2007 at 23:42:24 labeled as rmpr02500
- o IronWare Image (Secondary)  
Version 2.5.0T143, Size 4137876 bytes, Check Sum 662e  
Compiled on Oct 15 2007 at 14:32:00 labeled as rmpr02500
- o LP Kernel Image (Monitor for LP Image Type 0)  
Version 2.5.0T155, Size 285248 bytes, Check Sum 5643  
Compiled on Oct 19 2007 at 23:08:32 labeled as rlb02500
- o LP IronWare Image (Primary for LP Image Type 0)  
Version 2.5.0T157, Size 2000853 bytes, Check Sum 1e45  
Compiled on Oct 20 2007 at 00:05:04 labeled as rlp02500
- o LP IronWare Image (Secondary for LP Image Type 0)  
Version 2.5.0T157, Size 1999406 bytes, Check Sum 04f4  
Compiled on Oct 10 2007 at 17:15:40 labeled as rlp02500
- o Boot-Monitor Image  
Version 2.5.0T145, Size 420184 bytes, Check Sum 5111  
Compiled on Oct 19 2007 at 23:09:14 labeled as rmb02500
- o Startup Configuration  
Size 4344 bytes, Check Sum 26b1  
Modified on 00:15:48 GMT+00 Tue Oct 23 2007

Boot Flash: Type AM29LV040B, Size 512 KB

- o Boot-Monitor Image  
Version 2.5.0T145, Size 420184 bytes, Check Sum 5111  
Compiled on Oct 19 2007 at 23:09:14 labeled as rmb02500

=====  
Line Card Slot 1

Code Flash: Type MT28F640J3, Size 16 MB

- o IronWare Image (Primary)  
Version 2.5.0T157, Size 2000853 bytes, Check Sum 1e45

## 7 Displaying flash memory and version information

```
Compiled on Oct 20 2007 at 00:05:04 labeled as rlp02500

o IronWare Image (Secondary)
  Version 2.5.0T157, Size 1999406 bytes, Check Sum 04f4
  Compiled on Oct 10 2007 at 17:15:40 labeled as rlp02500

o Boot-Monitor Image
  Version 2.5.0T155, Size 285248 bytes, Check Sum 5643
  Compiled on Oct 19 2007 at 23:08:32 labeled as rlb02500

Boot Flash: Type AM29LV040B, Size 512 KB
o Boot-Monitor Image
  Version 2.5.0T155, Size 285248 bytes, Check Sum 5643
  Compiled on Oct 19 2007 at 23:08:32 labeled as rlb02500

=====
Line Card Slot 17
Code Flash: Type MT28F640J3, Size 16 MB
o IronWare Image (Primary)
  Version 2.5.0T157, Size 2000853 bytes, Check Sum 1e45
  Compiled on Oct 20 2007 at 00:05:04 labeled as rlp02500
o IronWare Image (Secondary)
  Version 2.5.0T157, Size 1999406 bytes, Check Sum 04f4
  Compiled on Oct 10 2007 at 17:15:40 labeled as rlp02500
o Boot-Monitor Image
  Version 2.5.0T155, Size 285248 bytes, Check Sum 5643
  Compiled on Oct 19 2007 at 23:08:32 labeled as rlb02500

Boot Flash: Type AM29LV040B, Size 512 KB
o Boot-Monitor Image
  Version 2.5.0T155, Size 285248 bytes, Check Sum 5643
  Compiled on Oct 19 2007 at 23:08:32 labeled as rlb02500

=====
Line Card Slot 31
Code Flash: Type MT28F640J3, Size 16 MB
o IronWare Image (Primary)
  Version 2.5.0T157, Size 2000853 bytes, Check Sum 1e45
  Compiled on Oct 20 2007 at 00:05:04 labeled as rlp02500
o IronWare Image (Secondary)
  Version 2.5.0T157, Size 1999406 bytes, Check Sum 04f4
  Compiled on Oct 10 2007 at 17:15:40 labeled as rlp02500
o Boot-Monitor Image
  Version 2.5.0T155, Size 285248 bytes, Check Sum 5643
  Compiled on Oct 19 2007 at 23:08:32 labeled as rlb02500
Boot Flash: Type AM29LV040B, Size 512 KB
o Boot-Monitor Image
  Version 2.5.0T155, Size 285248 bytes, Check Sum 5643
  Compiled on Oct 19 2007 at 23:08:32 labeled as rlb02500

=====
All show flash done
```



**TABLE 25 Code flash and boot flash information**

| This field...                                              | Displays...                                                                                                                                                                                                                                                                                                                                                                                                                                                                                                                                                                                                                                                                                                                                                                                                                                                                                                                                                                                                                       |
|------------------------------------------------------------|-----------------------------------------------------------------------------------------------------------------------------------------------------------------------------------------------------------------------------------------------------------------------------------------------------------------------------------------------------------------------------------------------------------------------------------------------------------------------------------------------------------------------------------------------------------------------------------------------------------------------------------------------------------------------------------------------------------------------------------------------------------------------------------------------------------------------------------------------------------------------------------------------------------------------------------------------------------------------------------------------------------------------------------|
| Management modules                                         |                                                                                                                                                                                                                                                                                                                                                                                                                                                                                                                                                                                                                                                                                                                                                                                                                                                                                                                                                                                                                                   |
| <type> Management Module (<location>)                      | The management module for which flash information is displayed. The <type> parameter indicates an active or standby management module. The <location> parameter indicates the top or bottom slot (M1 or M2, respectively).                                                                                                                                                                                                                                                                                                                                                                                                                                                                                                                                                                                                                                                                                                                                                                                                        |
| Code Flash                                                 | The model number and size of the management module's code flash.                                                                                                                                                                                                                                                                                                                                                                                                                                                                                                                                                                                                                                                                                                                                                                                                                                                                                                                                                                  |
| IronWare Image (Primary or Secondary)                      | <p>Indicates the IronWare image installed in the primary or secondary location in the management module's code flash. The image name format is described in <a href="#">"Software image naming conventions"</a> on page 165. The actual image name depends on the version of software you have running on your BigIron RX Series switch.</p> <p>The output displays the following information about the image:</p> <ul style="list-style-type: none"> <li>• Version – "2.3.0Txy" indicates the image version number. The "Txy" is used by Brocade for record keeping. The "xx" indicates the hardware type, while the "y" indicates the image type.</li> <li>• Size – The size, in bytes, of the image.</li> <li>• Check sum – A unique ID for the image. If the contents of the image change, the check sum changes also.</li> <li>• Compilation date and time – The date and time that Brocade compiled the image.</li> </ul>                                                                                                   |
| LP Kernel Image (Monitor for LP Image Type 0)              | <p>Indicates the interface modules Boot-Monitor image stored in the management module's code flash. The management module stores these images only; it does not run the images. The image name format is described in <a href="#">"Software image naming conventions"</a> on page 165. The output displays the following information about the image:</p> <ul style="list-style-type: none"> <li>• Version – "2.3.0Txy" indicates the image version number. The "Txy" is used by Brocade for record keeping. The "xx" indicates the hardware type, while the "y" indicates the image type.</li> <li>• Size – The size, in bytes, of the image.</li> <li>• Check sum – A unique ID for the image. If the contents of the image change, the check sum changes also.</li> <li>• Compilation date and time – The date and time that Brocade compiled the image.</li> </ul>                                                                                                                                                            |
| LP IronWare Image (Primary or Secondary for Module Type 0) | <p>Indicates the interface modules' primary or secondary IronWare image stored in the management module's code flash if you copied the primary or secondary IronWare image to all interface modules using the <b>copy</b> command with the <b>all</b> keyword. The management module stores these images only; it does not run the images. The image name format is described in <a href="#">"Software image naming conventions"</a> on page 165. The output displays the following information about the image:</p> <ul style="list-style-type: none"> <li>• Version – "2.3.0Txy" indicates the image version number. The "Txy" is used by Brocade for record keeping. The "xx" indicates the hardware type, while the "y" indicates the image type.</li> <li>• Size – The size, in bytes, of the image.</li> <li>• Check sum – A unique ID for the image. If the contents of the image change, the check sum changes also.</li> <li>• Compilation date and time – The date and time that Brocade compiled the image.</li> </ul> |

**TABLE 25 Code flash and boot flash information (Continued)**

| This field...                         | Displays...                                                                                                                                                                                                                                                                                                                                                                                                                                                                                                                                                                                                                                                                                                                                                                                                 |
|---------------------------------------|-------------------------------------------------------------------------------------------------------------------------------------------------------------------------------------------------------------------------------------------------------------------------------------------------------------------------------------------------------------------------------------------------------------------------------------------------------------------------------------------------------------------------------------------------------------------------------------------------------------------------------------------------------------------------------------------------------------------------------------------------------------------------------------------------------------|
| Boot-Monitor Image                    | <p>Indicates the monitor image installed in the management module's code flash. The image name format is described in <a href="#">"Software image naming conventions"</a> on page 165. The output displays the following information about the image:</p> <ul style="list-style-type: none"> <li>• Version – "2.3.0Txy" indicates the image version number. The "Txy" is used by Brocade for record keeping. The "xx" indicates the hardware type, while the "y" indicates the image type.</li> <li>• Size – The size, in bytes, of the image.</li> <li>• Check sum – A unique ID for the image. If the contents of the image change, the check sum changes also.</li> <li>• Compilation date and time – The date and time that Brocade compiled the image.</li> </ul>                                      |
| Startup Configuration                 | <p>The output displays the following information about the startup configuration, which is saved in the management module's code flash:</p> <ul style="list-style-type: none"> <li>• Size – Size, in bytes, of the startup configuration.</li> <li>• Check sum – A unique ID for the file. If the contents of the file change, the check sum changes also.</li> <li>• Modification date and time – Date and time that the startup configuration was last saved.</li> </ul>                                                                                                                                                                                                                                                                                                                                  |
| Boot Flash                            | The model number and size of the management module's boot flash.                                                                                                                                                                                                                                                                                                                                                                                                                                                                                                                                                                                                                                                                                                                                            |
| Boot-Monitor Image                    | <p>Indicates the boot image installed in the management module's boot flash. The image name format is described in <a href="#">"Software image naming conventions"</a> on page 165. The output displays the following information about the image:</p> <ul style="list-style-type: none"> <li>• Version – "2.3.0Txy" indicates the image version number. The "Txy" is used by Brocade for record keeping. The "xx" indicates the hardware type, while the "y" indicates the image type.</li> <li>• Size – The size, in bytes, of the image.</li> <li>• Check sum – A unique ID for the image. If the contents of the image change, the check sum changes also.</li> <li>• Compilation date and time – The date and time that Brocade compiled the image.</li> </ul>                                         |
| <b>Interface Modules</b>              |                                                                                                                                                                                                                                                                                                                                                                                                                                                                                                                                                                                                                                                                                                                                                                                                             |
| Line Card Slot <number>               | <p>The interface module for which flash information is displayed. The &lt;number&gt; parameter indicates the number of the chassis slot, 1 – 16, in which the interface module is installed.</p>                                                                                                                                                                                                                                                                                                                                                                                                                                                                                                                                                                                                            |
| Code Flash                            | The model number and size of the interface module's code flash.                                                                                                                                                                                                                                                                                                                                                                                                                                                                                                                                                                                                                                                                                                                                             |
| IronWare Image (Primary or Secondary) | <p>Indicates the IronWare image installed in the primary or secondary location in the interface module's code flash. The image name format is described in <a href="#">"Software image naming conventions"</a> on page 165. The output displays the following information about the image:</p> <ul style="list-style-type: none"> <li>• Version – "2.3.0Txy" indicates the image version number. The "Txy" is used by Brocade for record keeping. The "xx" indicates the hardware type, while the "y" indicates the image type.</li> <li>• Size – The size, in bytes, of the image.</li> <li>• Check sum – A unique ID for the image. If the contents of the image change, the check sum changes also.</li> <li>• Compilation date and time – The date and time that Brocade compiled the image.</li> </ul> |

**TABLE 25 Code flash and boot flash information (Continued)**

| This field...      | Displays...                                                                                                                                                                                                                                                                                                                                                                                                                                                                                                                                                                                                                                                                                                                                                        |
|--------------------|--------------------------------------------------------------------------------------------------------------------------------------------------------------------------------------------------------------------------------------------------------------------------------------------------------------------------------------------------------------------------------------------------------------------------------------------------------------------------------------------------------------------------------------------------------------------------------------------------------------------------------------------------------------------------------------------------------------------------------------------------------------------|
| Boot Flash         | The model number and size of the interface module's boot flash.                                                                                                                                                                                                                                                                                                                                                                                                                                                                                                                                                                                                                                                                                                    |
| Boot-Monitor Image | <p>Indicates the boot image installed in the interface module's boot flash. The image name format is described in <a href="#">"Software image naming conventions"</a> on page 165. The output displays the following information about the image:</p> <ul style="list-style-type: none"> <li>• Version – "2.3.0Txy" indicates the image version number. The "Txy" is used by Brocade for record keeping. The "xx" indicates the hardware type, while the "y" indicates the image type.</li> <li>• Size – The size, in bytes, of the image.</li> <li>• Check sum – A unique ID for the image. If the contents of the image change, the check sum changes also.</li> <li>• Compilation date and time – The date and time that Brocade compiled the image.</li> </ul> |

## Displaying version information

You can display version information for a BigIron RX Series switch using the **show version** command as shown in the following:

```
BigIron RX#show version
=====
HW: BigIron RX Router
BI-RX-32-S Backplane (Serial #: Not Exist, Part #: Not Exist)
RX-BI-32-SFM Switch Fabric Module 1 (Serial #: PR40060023, Part #: Not Exist)
SBRIDGE Version: 6, CPLD Version: 2
FE 1: Type fe200, Version 2
FE 2: Type fe200, Version 2
FE 3: Type fe200, Version 2
FE 4: Type fe200, Version 2
FE 5: Type fe200, Version 2
FE 6: Type fe200, Version 2
RX-BI-32-SFM Switch Fabric Module 2 (Serial #: PR40060026, Part #: Not Exist)
SBRIDGE Version: 6, CPLD Version: 2
FE 1: Type fe200, Version 2
FE 2: Type fe200, Version 2
FE 3: Type fe200, Version 2
FE 4: Type fe200, Version 2
FE 5: Type fe200, Version 2
FE 6: Type fe200, Version 2
RX-BI-32-SFM Switch Fabric Module 3 (Serial #: PR40060039, Part #: Not Exist)
SBRIDGE Version: 6, CPLD Version: 2
FE 1: Type fe200, Version 2
FE 2: Type fe200, Version 2
FE 3: Type fe200, Version 2
FE 4: Type fe200, Version 2
FE 5: Type fe200, Version 2
FE 6: Type fe200, Version 2
RX-BI-32-SFM Switch Fabric Module 4 (Serial #: PR40060027, Part #: Not Exist)
SBRIDGE Version: 6, CPLD Version: 2
FE 1: Type fe200, Version 2
FE 2: Type fe200, Version 2
FE 3: Type fe200, Version 2
FE 4: Type fe200, Version 2
FE 5: Type fe200, Version 2
```

## 7 Displaying flash memory and version information

```
FE 6: Type fe200, Version 2
RX-BI-32-SFM Switch Fabric Module 5 (Serial #: PR40060009, Part #: Not Exist)
SBRIDGE Version: 6, CPLD Version: 2
FE 1: Type fe200, Version 2
FE 2: Type fe200, Version 2
FE 3: Type fe200, Version 2
FE 4: Type fe200, Version 2
FE 5: Type fe200, Version 2
FE 6: Type fe200, Version 2
RX-BI-32-SFM Switch Fabric Module 6 (Serial #: PR40060007, Part #: Not Exist)
SBRIDGE Version: 6, CPLD Version: 2
FE 1: Type fe200, Version 2
FE 2: Type fe200, Version 2
FE 3: Type fe200, Version 2
FE 4: Type fe200, Version 2
FE 5: Type fe200, Version 2
FE 6: Type fe200, Version 2
RX-BI-32-SFM Switch Fabric Module 7 (Serial #: PR40060037, Part #: Not Exist)
SBRIDGE Version: 6, CPLD Version: 2
FE 1: Type fe200, Version 2
FE 2: Type fe200, Version 2
FE 3: Type fe200, Version 2
FE 4: Type fe200, Version 2
FE 5: Type fe200, Version 2
FE 6: Type fe200, Version 2
RX-BI-32-SFM Switch Fabric Module 8 (Serial #: PR40060020, Part #: Not Exist)
SBRIDGE Version: 6, CPLD Version: 2
FE 1: Type fe200, Version 2
FE 2: Type fe200, Version 2
FE 3: Type fe200, Version 2
FE 4: Type fe200, Version 2
FE 5: Type fe200, Version 2
FE 6: Type fe200, Version 2
=====
SL M1: RX-BI-32-MR Management Module Active (Serial #: Not Exist, Part #: Not Exist):
Boot      : Version 2.5.0T145 Copyright (c) 1996-2007 Foundry Networks, Inc.
Compiled on Oct 19 2007 at 23:09:14 labeled as rmb02500
(420184 bytes) from boot flash
Monitor   : Version 2.5.0T145 Copyright (c) 1996-2007 Foundry Networks, Inc.
Compiled on Oct 19 2007 at 23:09:14 labeled as rmb02500
(420184 bytes) from code flash
IronWare  : Version 2.5.0T143 Copyright (c) 1996-2007 Foundry Networks, Inc.
Compiled on Oct 19 2007 at 23:42:24 labeled as rmp02500

(4141014 bytes) from Primary
Board ID : 00 MBRIDGE32 Revision : 18
916 MHz Power PC processor (version 8003/0101) 166 MHz bus
512 KB Boot Flash (AM29LV040B), 32 MB Code Flash (MT28F128J3)
512 MB DRAM
Active Management uptime is 20 hours 53 minutes 45 seconds
=====
SL M2: RX-BI-32-MR Management Module Standby (Serial #: Not Exist, Part #: Not Exist):
Boot      : Version 2.5.0T145 Copyright (c) 1996-2007 Foundry Networks, Inc.
Compiled on Oct 19 2007 at 23:09:14 labeled as rmb02500

(420184 bytes) from boot flash
Monitor   : Version 2.5.0T145 Copyright (c) 1996-2007 Foundry Networks, Inc.
Compiled on Oct 19 2007 at 23:09:14 labeled as rmb02500
```

(420184 bytes) from code flash  
 IronWare : Version 2.5.0T143 Copyright (c) 1996-2007 Foundry Networks, Inc.  
 Compiled on Oct 19 2007 at 23:42:24 labeled as rmp02500

(4141014 bytes) from Primary  
 Board ID : 00 MBRIDGE32 Revision : 18  
 916 MHz Power PC processor (version 8003/0101) 166 MHz bus  
 512 KB Boot Flash (AM29LV040B), 32 MB Code Flash (MT28F128J3)  
 512 MB DRAM  
 Standby Management uptime is 20 hours 53 minutes 45 seconds  
 =====  
 SL 1: RX-BI-24F 24-port 1 GbE Module (Serial #: SA40050108, Part #: 31520-000G)  
 Boot : Version 2.5.0T155 Copyright (c) 1996-2007 Foundry Networks, Inc.  
 Compiled on Oct 19 2007 at 23:08:32 labeled as rlb02500

(285248 bytes) from boot flash  
 Monitor : Version 2.5.0T155 Copyright (c) 1996-2007 Foundry Networks, Inc.  
 Compiled on Oct 19 2007 at 23:08:32 labeled as rlb02500

(285248 bytes) from code flash  
 IronWare : Version 2.5.0T157 Copyright (c) 1996-2007 Foundry Networks, Inc.  
 Compiled on Oct 20 2007 at 00:05:04 labeled as rlp02500

(2000853 bytes) from Primary  
 FAP 1 version: 2  
 FAP 2 version: 2  
 FAP 3 version: 0  
 FAP 4 version: 0  
 660 MHz Power PC processor 440GP (version 8020/0020) 330 MHz bus  
 512 KB Boot Flash (AM29LV040B), 16 MB Code Flash (MT28F640J3)  
 512 MB DRAM, 8 KB SRAM, 0 Bytes BRAM  
 LP Slot 1 uptime is 20 hours 53 minutes 45 seconds  
 =====  
 SL 15: RX-BI-48T 48-port 1 GbE mini-RJ21 Telco Module (Serial #: PR46050004, Part #: Not Exist)  
 Boot : Version 2.5.0T155 Copyright (c) 1996-2007 Foundry Networks, Inc.  
 Compiled on Oct 12 2007 at 23:05:00 labeled as rlb02500

(285154 bytes) from boot flash  
 Monitor : Version 2.5.0T155 Copyright (c) 1996-2007 Foundry Networks, Inc.  
 Compiled on Oct 19 2007 at 23:08:32 labeled as rlb02500

(285248 bytes) from code flash  
 IronWare : Version 2.5.0T157 Copyright (c) 1996-2007 Foundry Networks, Inc.  
 Compiled on Oct 20 2007 at 00:05:04 labeled as rlp02500

(2000853 bytes) from Primary  
 FAP 1 version: 2  
 FAP 2 version: 2  
 FAP 3 version: 2  
 FAP 4 version: 2  
 660 MHz Power PC processor 440GP (version 8020/0020) 330 MHz bus  
 512 KB Boot Flash (AM29LV040B), 16 MB Code Flash (MT28F640J3)  
 512 MB DRAM, 8 KB SRAM, 0 Bytes BRAM  
 LP Slot 15 uptime is 20 hours 53 minutes 45 seconds  
 =====  
 SL 32: RX-BI-24C 24-port 1 GbE Copper Module (Serial #: SA05061147, Part #: 31521-001C)  
 Boot : Version 2.5.0T155 Copyright (c) 1996-2007 Foundry Networks, Inc.  
 Compiled on Oct 19 2007 at 23:08:32 labeled as rlb02500

## 7 Upgrading the BigIron RX Series software

```
(285248 bytes) from boot flash
Monitor : Version 2.5.0T155 Copyright (c) 1996-2007 Foundry Networks, Inc.
Compiled on Oct 19 2007 at 23:08:32 labeled as rlb02500
(285248 bytes) from code flash
IronWare : Version 2.5.0T157 Copyright (c) 1996-2007 Foundry Networks, Inc.
Compiled on Oct 20 2007 at 00:05:04 labeled as rlp02500

(2000853 bytes) from Primary
FAP 1 version: 2
FAP 2 version: 2
FAP 3 version: 0
FAP 4 version: 0
660 MHz Power PC processor 440GP (version 8020/0020) 330 MHz bus
512 KB Boot Flash (AM29LV040B), 16 MB Code Flash (MT28F640J3)
512 MB DRAM, 8 KB SRAM, 0 Bytes BRAM
LP Slot 32 uptime is 20 hours 53 minutes 46 seconds
=====
All show version done
```

**Syntax:** show version

## Upgrading the BigIron RX Series software

This section describes the upgrade procedures required to operate a BigIron RX. Read this section before you upgrade the BigIron RX software. It contains the following information:

- [“Changes to software images starting with version 02.5.00”](#)
- [“Unified software image upgrade to upgrade release 02.6.00 and later”](#)
- [“Upgrading software releases prior to release 02.2.01”](#)
- [“Hitless Layer 2 OS upgrade”](#)
- [“Basic tasks in the software upgrade process”](#)
- [“Upgrading the management module’s monitor and boot images”](#)
- [“Upgrading the management module’s IronWare image”](#)
- [“Rebooting the management module”](#)
- [“Upgrading the MBRIDGE FPGA on the management module”](#)

### Changes to software images starting with version 02.5.00

Depending on the versions you are upgrading from or to, the procedures can be different. Follow the procedures described in the following sections:

- [“Special instructions for using interface modules in a 32-Slot chassis”](#)
- [“For interface modules running versions earlier than 02.3.00”](#)
- [“Separation of boot and monitor images”](#)
- [“Upgrading to version 02.5.00 \(or later\) from a pre- 02.5.00 version”](#)
- [“Downgrading from version 02.5.00 \(or later\) to a pre-02.5.00 version”](#)

### ***Special instructions for using interface modules in a 32-Slot chassis***

The BigIron RX-32 chassis introduced with this release can use interface modules in the BigIron RX series that have older versions of the Multi-Service IronWare software installed on them. There are however a couple of issues regarding older versions of the software that might be installed on interface modules that you already own. They can work properly but must be installed as described in the following:

#### ***For interface modules running versions earlier than 02.3.00***

Under normal conditions, a back revision Interface module can be placed in a BigIron RX chassis and the Management module will automatically upgrade it to the Interface module software images that it has installed on the Management module. If you are running one of the versions of Multi-Service IronWare software prior to 02.3.00, the automatic upgrade will only occur if the Interface module is installed in slots 1 - 16 of the BigIron RX-32 chassis. If you install an Interface module with a software version earlier than 02.3.00 in slots 17 - 32, it will not download a new image and will cause instability in the BigIron RX system.

To avoid this problem, you must upgrade the software revision before installing an Interface module in slots 17 - 32 of a BigIron RX-32 chassis using one of the methods described in [“Upgrading the interface module’s IronWare image”](#).

#### ***Separation of boot and monitor images***

Beginning with version 02.5.00 and later of the Multi-Service IronWare software, the boot and monitor images no longer need to be upgraded with each release.

- The Boot images no longer need to be upgraded with each release and in fact will almost never need to be changed. This eliminates one extra step in the upgrade process, thus simplifying the upgrade procedure, reducing the chance of operator error and leading to a faster upgrade process.
- The Monitor image no longer needs to be upgraded with each release. In release 02.5.00, all OS functions have been moved out of the Monitor image into the IronWare image. This has simplified the Monitor image and it no longer needs to be upgraded every time, thus eliminating another step in the upgrade process.
- The first version of the boot and monitor image supporting this separation is 02.5.00

#### ***Upgrading to version 02.5.00 (or later) from a pre- 02.5.00 version***

The procedure for upgrading the software images to version 02.5.00 (or later) from a pre-02.5.00 version are the same as for previous versions. When performing this upgrade, you should upgrade the Boot, Monitor, and IronWare images in addition to any FPGA images that need to be upgraded.

Follow the steps given below for this upgrade.

1. Determine the versions of the software images currently installed and running on the router.  
Use the procedures described in [“Displaying flash memory and version information”](#) on page 166. Using this procedure you can determine the images currently installed.
2. Upgrade the Management and Interface Modules IronWare Image with the Unified Image.  
Use the procedures described in [“Unified software image upgrade to upgrade release 02.6.00 and later”](#).

3. Reboot the Management Module.

Use the procedures described in [“Rebooting the management module”](#) on page 183.

### ***Downgrading from version 02.5.00 (or later) to a pre-02.5.00 version***

The procedure for downgrading the software images from version 02.5.00 (or later) to a pre-02.5.00 version are the same as for previous versions. When performing this upgrade, you should upgrade the Boot, Monitor, and IronWare images in addition to any FPGA images that need to be upgraded.

Follow the steps given below for this upgrade..

1. Determine the versions of the software images currently installed and running on the router.  
Use the procedures described in [“Displaying flash memory and version information”](#) on page 166.
2. Upgrade the Management and Interface Modules IronWare Image with the Unified Image.  
Use the procedures described in [“Unified software image upgrade to upgrade release 02.6.00 and later”](#) on page 177.
3. If required for this release, upgrade the Management module’s MBRIDGE FPGA image.  
Use the procedures described in [“Upgrading the MBRIDGE FPGA on the management module”](#) on page 183.
4. If required for this release, upgrade the Interface module’s FPGA images.  
Use the procedures described in [“Upgrading the MBRIDGE FPGA on the management module”](#) on page 183.
5. Reboot the Management Module.  
Use the procedures described in [“Rebooting the management module”](#) on page 183.

## **Command change**

Beginning with version 02.5.00 and later of the Multi-Service IronWare software, the **copy tftp image** command has been changed to enable the user to upgrade the boot, monitor, and MBRIDGE only when needed.

---

### **NOTE**

The changes to the **copy tftp image** command will appear when upgrading to any version after 02.5.00.

---

### **New default behavior**

- Without any options selected, the unified image will copy the MP monitor, LP monitor, and the MP and LP applications to the primary location.
- The option to exclude copying the MBRIDGE and exclude copying the boot from the unified image was removed.
- Unified images will now include two MBRIDGES; one for BigIron RX-16/8/4 (mbridge18.xsvf) and one for the BigIron RX-32(mbridge32.xsvf).



**New options added**

New options have been added to the **copy tftp image** command to enable the user to upgrade the boot, monitor, and MBRIDGE only when needed.

**Syntax:** copy tftp image <TFTP-server-ip-addr> <image-name> [lp-boot | lp-sec | mp-boot | mp-sec | mbridge]

The <TFTP-server-ip-addr> variable is the IP address for the TFTP server you are downloading the image from.

The <image-name> variable is the name of the unified software image you want to download to the switch.

The **lp-boot** parameter specifies that you want to download the new interface module boot image.

The **lp-sec** parameter specifies that interface image be copied to the secondary location in flash.

The **mbridge** parameter tells the BigIron RX to copy the MBRIDGE image. It will now include two MBRIDGES; one for BigIron RX-16/8/4 (mbridge18.xsvf) and one for the BigIron RX-32(mbridge32.xsvf).

The **mp-boot** parameter specifies that you want to download the new management module boot image.

The **mp-sec** parameter specifies that management image be copied to the secondary location in flash.

**Unified software image upgrade to upgrade release 02.6.00 and later**

BigIron RX software release 02.6.00 and later can be upgraded using the Unified Software Image Upgrade procedure. When copying the image, you must load the **lp-boot** and **mp-boot**. You can set parameters to limit the images being copied and to direct images to be copied to the secondary image location to a later release by doing the following.

**NOTE**

Failure to load the **lp-boot** and **mp-boot** when copying the unified image will cause the LP to become stuck in an interactive mode.

1. Copy the unified software image (rx02700.bin) from a TFTP server to the switch.

For example, to copy the entire unified software image, the **lp-boot** and the **mp-boot** from a TFTP server at IP address 10.10.12.12, use the following command.

```
BigIron RX#copy tftp image 10.10.12.12 rx02500.bin lp-boot mp-boot
```

**Syntax:** copy tftp image <TFTP-server-ip-addr> <image-name> [lp-boot | lp-sec | mp-boot | mp-sec | mbridge]

The <TFTP-server-ip-addr> variable is the IP address for the TFTP server you are downloading the image from.

The <image-name> variable is the name of the unified software image you want to download to the switch.

The <image-name> variable is the name of the unified software image you want to download to the switch. Image names are assigned as follows:

**TABLE 26** Image name

| Device     | Image name  | Example     |
|------------|-------------|-------------|
| BigIron RX | rxxxxxx.bin | rx02700.bin |

The **ip-boot** parameter specifies that you want to download the new interface module boot image.

The **ip-sec** parameter specifies that interface image be copied to the secondary location in flash.

The **mbridge** parameter tells the BigIron RX to copy the MBRIDGE image. It will now include two MBRIDGES; one for BigIron RX-16/8/4 (mbridge21.xsvf) and one for the BigIron RX-32(mbridge32.xsvf).

The **mp-boot** parameter specifies that you want to download the new management module boot image. The **mp-sec** parameter specifies that management image be copied to the secondary location in flash.

2. Reboot the management module using the **reload** command. (Refer to [“Rebooting the management module”](#) on page 183.)
3. If you are using SSH v2, you must clear the crypto key using the **crypto key zeroize** command after you upgrade. Then, regenerate a new crypto key using the **crypto key generate** command.

## Unified software image upgrade to upgrade release 02.2.01 to 02.5.00

BigIron RX software release 02.2.01 to 02.5.00 can be upgraded using the Unified Software Image Upgrade procedure. This new procedure removes the need to copy multiple images in separate steps. In addition, you can set parameters to limit the images being copied and to direct images to be copied to the secondary image location to a later release by doing the following.

1. Copy the unified software image (rx02700.bin) from a TFTP server to the switch.

For example, to copy the entire unified software image from a TFTP server at IP address 10.10.12.12, use the following command.

```
BigIron RX#copy tftp image 10.10.12.12 rx02500.bin
```

**Syntax:** copy tftp image <TFTP-server-ip-addr> <image-name> [ip-no-boot | ip-sec mp-no-boot | mp-sec | no-mbridge]

The <TFTP-server-ip-addr> variable is the IP address for the TFTP server you are downloading the image from.

The <image-name> variable is the name of the unified software image you want to download to the switch. Image names are assigned as follows:

**TABLE 27** Image name

| Device     | Image name  | Example     |
|------------|-------------|-------------|
| BigIron RX | rxxxxxx.bin | rx02700.bin |

The **ip-no-boot** parameter specifies that you do not want to download the interface module boot image.

The **ip-sec** parameter specifies that interface image be copied to the secondary location in flash.

The **mp-no-boot** parameter specifies that you do not want to download the management module boot image.

The **mp-sec** parameter specifies that management image be copied to the secondary location in flash.

The **no-mbridge** parameter tells the BigIron RX not to copy the MBRIDGE image.

2. Reboot the management module using the **reload** command. (Refer to [“Rebooting the management module”](#) on page 183.)
3. If you are using SSH v2, you must clear the crypto key using the **crypto key zeroize** command after you upgrade to Release 02.2.01. Then, regenerate a new crypto key using the **crypto key generate** command.

## Upgrading software releases prior to release 02.2.01

If your BigIron RX is running a release prior to Release 02.2.01, you must upgrade the management module and interface module images separately. Follow the steps given below for this upgrade.

1. Upgrade the monitor and boot images on the management and interface modules. See the following sections:
  - [“Upgrading the management module’s monitor and boot images”](#) on page 180
  - [“Upgrading the management module’s IronWare image”](#) on page 180
  - [“Upgrading the interface module’s monitor and boot images”](#) on page 181
  - [“Upgrading the interface module’s IronWare image”](#) on page 182
2. Upgrade the MBRIDGE FPGA. Refer to [“Upgrading the MBRIDGE FPGA on the management module”](#) on page 183.
3. Reboot the management module. Refer to [“Rebooting the management module”](#) on page 183.
4. If you are using SSH v2, clear and regenerate a new crypto key.

## Basic tasks in the software upgrade process

Follow the steps given below to upgrade all or some of the BigIron RX Series software images.

1. Determine the versions of the software images currently installed and running on the BigIron RX Series system.
2. Copy the new software image from a source to a destination.

The source from which to copy the new image is usually a TFTP server to which the BigIron RX Series system has access or a PCMCIA flash card inserted in the management module’s slot 1 or 2. The destination to which to copy the new image is either the management module’s code flash or a flash card inserted in slot 1 or 2, or all or one specified interface module.

3. Reboot the management module.

For information about performing this task, Refer to [“Rebooting the management module”](#) on page 183.

## Upgrading the management module’s monitor and boot images

You can upgrade the management module’s monitor and boot images simultaneously.

---

### NOTE

Brocade highly recommends that the interface monitor and boot images be upgraded at the same time as the management’s module images to keep both code images synchronized on the same version. The procedure for doing this is described in [“Upgrading the interface module’s monitor and boot images”](#) on page 181.

---

Follow the steps given below to upgrade the management module’s monitor and boot images simultaneously.

1. Place the new monitor and boot images on a TFTP server to which the BigIron RX Series system has access or on a PCMCIA flash card inserted in slot 1 or 2.
2. Copy the new monitor and boot images to the BigIron RX Series. Enter one of the following commands at the Privileged EXEC level of the CLI (example: BigIron RX#):

**TABLE 28 Command syntax for upgrading monitor and boot images on the management module**

| Command syntax                                                         | Description                                                                          |
|------------------------------------------------------------------------|--------------------------------------------------------------------------------------|
| <b>copy tftp flash</b> <ip-addr> <image-name> <b>monitor copy-boot</b> | Copies the latest monitor and boot images from the TFTP server to flash.             |
| <b>copy slot1   slot2 flash</b> <image-name> <b>monitor copy-boot</b>  | Copies the latest monitor and boot images from a flash card in slot 1 or 2 to flash. |

For information about the image name to specify, refer to [Table 24](#).

3. Verify that the new monitor and boot images have been successfully copied to the flash or slot 1 or 2 by entering one of the following commands at the Privileged EXEC level of the CLI:
  - show flash
  - **dir /<path-name>/** (if the destination is slot 1 or 2)

Check for the boot image, monitor image, and the date and time at which the new images were built.
4. If you want to upgrade other software images, go to the appropriate upgrade section for information. If you have completed upgrading the software images, you must reboot the management module to complete the upgrade process. For more information, refer to [“Rebooting the management module”](#) on page 183.

## Upgrading the management module’s IronWare image

Perform the following steps to upgrade the management module’s IronWare image (primary or secondary).

1. Place the new IronWare image on a TFTP server to which the BigIron RX Series system has access or on a PCMCIA flash card inserted in slot 1 or 2.

2. Copy the new IronWare image from the TFTP server or a flash card in slot 1 or 2 to the management module's code flash or a flash card in slot 1 or 2. To perform this step, enter one of the following commands at the Privileged EXEC level of the CLI:
  - **copy tftp flash** <ip-addr> <image-name> **primary | secondary**
  - **copy tftp slot1 | slot2** <ip-addr> <image-name> **primary | secondary**
  - **copy slot1 | slot2 flash** <image-name> **primary | secondary**
  - **copy slot1 | slot2 slot1 | slot2** <image-name> <dest-name>
 For information about the image name to specify, refer to [Table 24](#).
3. Verify that the new IronWare image has been successfully copied to the specified destination by entering one of the following commands at the Privileged EXEC level of the CLI:
  - **show flash** (if the destination was code flash)
  - **dir /<path-name>/** (if the destination was slot 1 or 2)
 Check for the primary or secondary image and the date and time that it was placed in the directory.
4. If you want to upgrade other software images, go to the appropriate upgrade section for information. If you have completed upgrading the software images, you must reboot the management module to complete the upgrade process. For more information, refer to [“Rebooting the management module”](#) on page 183.

## Upgrading the interface module's monitor and boot images

### NOTE

We recommend that you perform this upgrade procedure from a PC or terminal that is directly connected to the management module's Console port. You can also perform this procedure through a Telnet or SSHv2 session.

Follow the steps given below to upgrade an interface's monitor and boot images simultaneously.

1. Place the new monitor and boot images on a TFTP server to which the BigIron RX Series system has access or on a PCMCIA flash card inserted in slot 1 or 2.
2. Copy the new monitor and boot images to the BigIron RX Series. Enter one of the following commands at the Privileged EXEC level of the CLI (example: BigIron RX#):

**TABLE 29** Command syntax for upgrading the monitor and boot images on the interface module

| Command syntax                                                                                | Description                                                                                                                                 |
|-----------------------------------------------------------------------------------------------|---------------------------------------------------------------------------------------------------------------------------------------------|
| <b>copy tftp ip</b> <ip-addr> <image-name> <b>monitor all   &lt;slot-number&gt;</b>           | Copies the latest monitor image from the TFTP server to all interface modules or to the specified interface module (slot-number).           |
| <b>copy tftp ip</b> <ip-addr> <image-name> <b>monitor copy-boot all   &lt;slot-number&gt;</b> | Copies the latest monitor and boot images from the TFTP server to all interface modules or to the specified interface module (slot-number). |

For information about the image name to specify, refer to [Table 24](#).

3. Verify that the new images were successfully copied to code flash by entering the following command at the Privileged EXEC level of the CLI:
  - **show flash**

Check for the monitor image, boot image, and the date and time at which the new images were built.

4. If you want to upgrade other software images, go to the appropriate upgrade section for information. If you have completed upgrading the software images, you must reboot the management module to complete the upgrade process. For more information, refer to [“Rebooting the management module”](#) on page 183.

## Upgrading the interface module’s IronWare image

Follow the steps given below to upgrade the IronWare image (primary or secondary) on all interface modules or an interface module in a specified chassis slot.

1. Place the new IronWare image on a TFTP server to which the BigIron RX Series system has access or on a PCMCIA flash card inserted in slot 1 or 2.
2. Copy the new IronWare image from the TFTP server or a flash card in slot 1 or 2 to all interface modules or an interface module in a specified chassis slot. To perform this step, enter one of the following commands at the Privileged EXEC level of the CLI (example: BigIron RX#):
  - **copy tftp lp** <ip-addr> <image-name> **primary** | **secondary** **all**
  - **copy tftp lp** <ip-addr> <image-name> **primary** | **secondary** <chassis-slot-number>
  - **copy slot1** | **slot2 lp** <image-name> **primary** | **secondary** **all**
  - **copy slot1** | **slot2 lp** <image-name> **primary** | **secondary** <chassis-slot-number>

For information about the image name to specify, refer to [Table 24](#).

---

### NOTE

If you copy the new IronWare image to all interface modules using the **all** keyword, the management module makes a copy of the image (called lp-primary-0 or lp-secondary-0) and stores it in its code flash, thereby synchronizing the new IronWare image on both the interface and management modules.

If you copy the new IronWare image to a specified chassis slot, the management module does not make a copy of the image or store it. In this case, the new IronWare image on the interface module is unsynchronized or different from the IronWare image on the management module.

For more information about synchronizing the new IronWare image or retaining unsynchronized versions of the IronWare image on the interface and management modules, refer to [“Rebooting the management module”](#) on page 183.

- 
3. Verify that the new IronWare image has been successfully copied by entering the following command at any level of the CLI:

- **show flash**

Check for the IronWare image and the date and time at which the image was built.

If you want to upgrade other software images, go to the appropriate upgrade section for information. If you have completed upgrading the software images, you must reboot the management module to complete the upgrade process. For more information, refer to [“Rebooting the management module”](#) on page 183.

## Rebooting the management module

After upgrading one or more software images on the management or interface modules, you must reboot the management module. After the management module reboots, it in turn reboots the interface modules.

To reboot the management module, enter one of the following commands:

- **reload** (this command boots from the default boot source, which is the primary code flash)
- `boot system flash primary | secondary`

During the management module reboot, the following synchronization events occur:

- If you have a standby management module, the active management module compares the standby module's monitor, primary, and secondary images to its own. If you have updated these images on the active module, the active module automatically synchronizes the standby module's images with its own.
- If you copied the primary or secondary IronWare image to all interface modules using the **copy** command with the **all** keyword, the management module made a copy of the image and stored it in its code flash under the names `lp-primary-0` or `lp-secondary-0`. By default, the BigIron RX Series system checks the interface modules' IronWare images, which reside in the code flash of the interface modules and the management module to make sure they are the same in both locations. (These IronWare images are stored on the management module only and are not run by the management or interface modules.) If the IronWare images on the interface and management modules are different, the system prompts you to do the following:
  - If you want to update the IronWare images in the interface module's code flash with the images in the management module's code flash, enter the **lp cont-boot sync <slot-number>** command at the Privileged EXEC prompt.
  - If you want to retain the IronWare images in the interface module's code flash, enter the **lp cont-boot no-sync <slot-number>** command at the Privileged EXEC prompt.

After the management module finishes booting, do the following:

- Enter the **show module** command at any CLI level, and verify that the status of all interface modules is `CARD_STATE_UP`.
- Enter the **show version** command at any CLI level, and verify that all management and interface modules are running the new software image version.

If you find that an interface module is in a waiting state or is running an older software image, then you may have forgotten to enter the **lp cont-boot sync <slot-number>** command at the Privileged EXEC prompt.

## Upgrading the MBRIDGE FPGA on the management module

BigIron RX Series management modules contain an upgradable FPGA image called MBRIDGE.

The MBRIDGE image installed must be compatible with the software version you are running on the BigIron RX Series. Refer to the Software Release Notes for compatibility information.

---

### NOTE

You will not need to upgrade the MBRIDGE FPGA image with every Multi-Service software upgrade. Only upgrade this image if specified in the release notes.

---

### *Overview of tasks in the FPGA image upgrade process*

Follow the steps given below to upgrade the MBRIDGE FPGA image on a BigIron RX Series management module.

1. Determine the versions of the images currently installed on the BigIron RX Series management module.

For information about performing this task, refer to “[Determining the MBRIDGE image versions](#)” on page 184.

2. Copy the new image from a source to a destination.

The source from which to copy the new image is usually a TFTP server to which the BigIron RX Series system has access or a flash card in the management module’s slot 1 or 2. The destination to which to copy the new image is all or one specified interface module.

For information about performing this task, refer to “[Upgrading the MBRIDGE FPGA image](#)” on page 185.

3. Reboot the interface module upon which you upgraded the MBRIDGE images.

### *Determining the MBRIDGE image versions*

To display the versions of the MBRIDGE images currently installed on the Gigabit Ethernet modules, enter the **show version** command at any level of the CLI:

```
BigIron RX>show version
HW: BigIron RX Switch
BI-RX-16-S Backplane (Serial #: SERI_BACK, Part #: BACK_PART_KAO)
RX-SFM3 Switch Fabric Module 1 (Serial #: Not Exist, Part #: 000)
=====
SL M2: BI-RX Management Module Active (Serial #: Not Exist, Part #: 31524-000A):
Boot      : Version 2.2.0T145 Copyright (c) 1996-2003 Foundry Networks, Inc.
Compiled on Jul 18 2005 at 18:53:23 labeled as rmb02200
(342853 bytes) from boot flash
Monitor   : Version 2.2.0T145 Copyright (c) 1996-2003 Foundry Networks, Inc.
Compiled on Jul 18 2005 at 18:53:23 labeled as rmb02200
(342853 bytes) from code flash
IronWare  : Version 2.2.0T143 Copyright (c) 1996-2003 Foundry Networks, Inc.
Compiled on Jul 18 2005 at 19:36:07 labeled as rmpr02200
(5031659 bytes) from Primary
Board ID  : 00 MBRIDGE Revision : 12
913 MHz Power PC processor (version 8003/0101) 166 MHz bus
512 KB Boot Flash (AM29LV040B), 32 MB Code Flash (MT28F128J3)
512 MB DRAM
Active Management uptime is 5 hours 12 minutes 39 seconds
```

The highlighted lines in the output indicate that the management module currently has MBRIDGE Revision: 12 installed.



## *Upgrading the MBRIDGE FPGA image*

Follow the steps given below to upgrade one or more MBRIDGE FPGA images on a BigIron RX Series management module.

1. Place the new MBRIDGE FPGA image on a TFTP server to which the BigIron RX Series system has access or on a PCMCIA flash card inserted in slot 1 or 2.
2. Copy the MBRIDGE FPGA image from the TFTP server or a flash card in slot 1 or 2 to all management modules or a management module in a specified chassis slot. To perform this step, enter one of the following commands at the Privileged EXEC level of the CLI (example: BigIron RX#):
  - **copy tftp mbridge <ip-addr> <image-name> MBRIDGE**
  - **copy slot1 | slot2 mbridge <image-name> MBRIDGE**
3. After the MBRIDGE upgrade is complete, the management module must be power-cycled.
4. Verify that the MBRIDGE images have been successfully copied to the specified interface modules by entering the following command at any level of the CLI:
  - **show version**

Check for the MBRIDGE image version numbers in the output.

## Hitless Layer 2 OS upgrade

Version 02.3.00a and later of the Multi-Service IronWare software support hitless upgrade of the operating system on a BigIron RX switch.

The hitless OS upgrade is designed to allow for upgrading the software in a system between two patch releases of the OS, which support this functionality and have compatible data structures. A hitless Layer 2 OS downgrade may also be supported if the current and target code releases have compatible data structures.

---

### NOTE

Hitless OS upgrade is not supported between major releases. It is supported only within a release. For example Hitless OS Upgrade is available when upgrading from software release 02.7.00a to 02.7.00b. It is not available when upgrading from software release 02.6.00 to 02.7.00.

---

From time to time, it may become necessary when enhancing the software or adding new features to change or add data structures making releases incompatible. In these cases, an upgrade or downgrade will not be hitless, and will fall back to using the regular Brocade upgrade process – relying on fast reboot.

The following guidance must be followed when performing a hitless OS upgrade or downgrade:

- Hitless upgrade or downgrade is not supported in 2.3.00.
- Hitless Layer 2 OS upgrade is supported between 2.3.00a and higher releases (unless indicated otherwise in the target software's release notes).
- Hitless upgrade maintains forwarding states and control plane functionality of the active software from which you are upgrading (i.e. 2.3.00a to 2.4.00 would only maintain the functionality supported by 2.3.00a).
- Hitless downgrades are recommended only between compatible patch releases of a feature release such as between 2.3.00b to 2.3.00a (to ensure the higher release has no functional enhancements that do not exist in the lower release).

Using this feature, you can upgrade the Multi-Service IronWare software without a loss of service or disruption in the following supported functions and protocols:

- All ports and links remain operational
- TOS-based QoS
- Layer-2 Switching
- Layer-2 Protocols:
  - MRP
  - STP
  - VSRP
  - RSTP
  - MSTP

### *Considerations when using the feature*

Consider the following when using this feature:

- You must have both active and standby management modules installed to use this feature.
- To avoid any disruptions of Layer-3 traffic to OSPF or BGP routes, the router must be configured with OSPF Graceful Restart and BGP Graceful Restart features. In addition, the device's OSPF neighbors must have OSPF Graceful Restart Helper enabled.
- The total time it takes for the hitless upgrade process to finish varies between approximately 1 and 10 minutes. This depends on the size of the MAC table, the number of OSPF and BGP neighbors and the size of the routing table. Router configuration is unavailable during the entire hitless upgrade process. The message "**—SW Upgrade In Progress - Please Wait—**" is printed at the console when configuration is attempted. Operational command of the router is allowed during the upgrade process.
- The active management module changes from the initial active management module to the standby management module during the hitless upgrade process. This makes it necessary to have a connection to the console interface on both management modules.
- Upon being reset, the management and interface module CPUs are unable to send and receive any packets. Once the management and interface modules are up and running, their CPUs are able to send and receive packets, even before the hitless upgrade process is complete.
- Router configuration is not allowed to be changed during the entire hitless upgrade process.
- System-max parameter changes or other configuration changes that require a system reload such as "cam-mode" and cam-profile" changes do not take effect upon hitless upgrade.
- FPGA images cannot be upgraded using the hitless upgrade process.
- This feature cannot be used to downgrade an image to an older major version than the version that the device is currently running.
- If there are protocol dependencies between neighboring nodes, it is recommended that only each node is upgraded: one node at a time.
- After hitless upgrade, the BigIron RX router will still have the same running configuration as it does before the upgrade. A configuration that is not saved before hitless reload is not removed and the existing startup configuration does not take effect. This behavior is the same as displayed by the management module switchover feature.

**NOTES:**

- Hitless upgrade is only supported from version 2600c or later 2600x patch releases and hitless downgrade to version 2600c or later 2600x patch releases.
- Due to Internal changes introduced in patch release version 02.6.00c, hitless upgrade is not supported on 02.6.00c and hitless downgrade is not supported from 02.6.00c.
- Due to Internal changes introduced in patch release version 02.3.00e, users cannot perform a hitless upgrade from earlier 02.3.00 versions to 2.3.00f or higher versions.
- Due to Internal changes introduced in patch release version 02.3.00f, users cannot perform a hitless upgrade from earlier 02.3.00 versions to 02.3.00g or higher versions.
- The hitless upgrade feature is not supported on release 02.5.00b to 02.5.00c for the BigIron RX-32 only. It is supported on all other BigIron RX devices.

***The hitless OS software process***

Follow the steps given below to perform hitless upgrade of Multi-Service IronWare software.

1. Version 02.3.00 or later of the Multi-Service IronWare software is installed in flash memory to the primary and secondary image on the active and standby management modules and interface modules.
2. The **hitless-reload** command is executed on the active management module.
3. The hitless upgrade process is begun on the active management module which initiates the upgrade process on the standby management module.
4. The standby management module is reset.
5. The active management module is reset and the standby management module assumes control as the active module.
6. Active console control is lost to the previously active management module as it becomes the standby management module.
7. The active management module initiates the upgrade process on all interface modules.
8. The router is now operating on the new Multi-Service IronWare software. The management module that was initially configured as the standby management module is now the active management module and the management module that was initially configured as the active management module is now the standby.

Figure 89 provides a detailed diagram of the Hitless reload process.

FIGURE 89 Management module (MP) and interface module (LP) hitless upgrade process

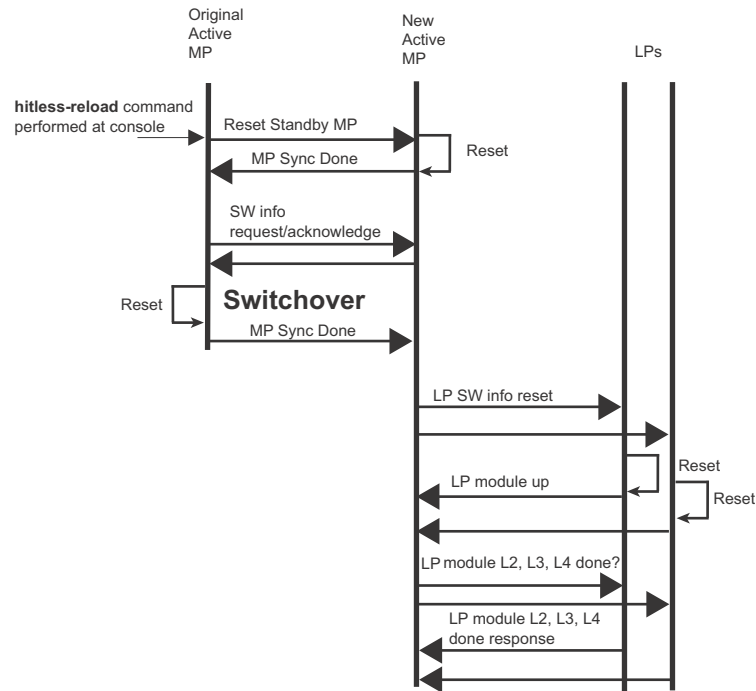

### Performing a hitless OS software upgrade

To perform a hitlessLayer 2 OS software upgrade, you must perform the following tasks:

- Copy version 02.3.00 or later of the Multi-Service IronWare software to the primary and secondary image on both the active and standby management modules and interface modules.
- Setup a console connection to both the active and standby management modules. These connections can be through a telnet, SSH, or serial console session.
- Type the **hitless-reload** command at the console of the active management module.

### Loading the Multi-Service IronWare software onto the router

Hitless Layer 2 OS upgrade loads from the primary and secondary images on the Management modules. The first step in performing a hitless Layer 2 OS upgrade is to copy the version 02.3.00 or later images into the flash memory of the active and standby management modules.

For instructions for copying these files, refer to [“Upgrading the management module’s monitor and boot images”](#) on page 180 and [“Upgrading the management module’s monitor and boot images”](#) on page 180.

### *Setting up consoles*

Hitless Layer 2 OS upgrade is executed at the active management module. During the process of upgrading the image, control of the router shifts to the standby management module. For this reason, you need to have management sessions enabled on both the active and the standby management modules. When the reload is complete, the management module that was in the standby condition at the beginning will be in the active state. If you want the original management module to be active, you must manually fail-over control to it.

### *Executing the hitless upgrade command*

To begin the process of a hitless upgrade, use the following command:

```
BigIron RX(config)# hitless-reload mp primary lp primary
```

**Syntax:** hitless-reload mp [primary | secondary ] lp [primary | secondary]

The **mp** parameter specifies that the management module will be reloaded with either the **primary** or **secondary** image as directed.

The **lp** parameter specifies that the interface module will be reloaded with either the **primary** or **secondary** image as directed.

### *Verify the new software image*

Enter the **show version** command at any CLI level, and verify that all management and interface modules are running the new software image version.

## Loading and saving configuration files

For easy configuration management, the BigIron RX Series switch supports both the download and upload of configuration files between the switch and a TFTP server on the network. You can also copy the startup configuration file locally between the management module's code flash and a PCMCIA flash card inserted in the management module's slot 1 or 2.

You can upload either the startup configuration file or the running configuration to the TFTP server, code flash, or a flash card for backup and use in booting the system.

- **Startup configuration file** – This file (startup-config) contains the configuration information that is currently saved in the management module's code flash. To display this file, enter the **show configuration** command at any CLI prompt.
- **Running configuration** – This active configuration is in the system RAM but not yet saved to code flash. These changes could represent a short-term requirement or general configuration change. To display this configuration, enter the **show running-config** or **write terminal** command at any CLI prompt.

Each device can have one startup configuration file and one running configuration. The startup configuration file is shared by both flash modules. The running configuration resides in DRAM.

## Replacing the startup configuration with the running configuration

After you make configuration changes to the active system, you can save those changes by writing them to code flash. When you write configuration changes to code flash, you replace the startup configuration with the running configuration.

To replace the startup configuration with the running configuration, enter the following command at any Enable or CONFIG command prompt:

```
BigIron RX# write memory
```

## Replacing the running configuration with the startup configuration

If you want to back out of the changes you have made to the running configuration and return to the startup configuration, enter the following command at the Privileged EXEC level of the CLI:

```
BigIron RX# reload
```

When the system detects differences between the running and startup configurations, it prompts you as follows:

```
Are you sure? (enter 'y' or 'n'):
```

Enter y, and press the Enter key.

## Logging changes to the startup-config file

You can configure a BigIron RX Series to generate a Syslog message when the startup-config file is changed. The trap is enabled by default.

The following Syslog message is generated when the startup-config file is changed:

```
startup-config was changed
```

If the startup-config file was modified by a valid user, the following Syslog message is generated:

```
startup-config was changed by <username>
```

To disable or re-enable Syslog messages when the startup-config file is changed, use the following command at the global CONFIG level of the CLI:

**Syntax:** [no] logging enable config-changed

## Copying a configuration file to or from a TFTP server

To copy the startup-config or running-config file to or from a TFTP server, use one of the following methods.

---

### NOTE

You can name the configuration file when you copy it to a TFTP server. However, when you copy a configuration file from the server to a BigIron RX Series, the file is always copied as “startup-config” or “running-config”, depending on which type of file you saved to the server.

---

To initiate transfers of configuration files to or from a TFTP server, enter one of the following commands at the Privileged EXEC level of the CLI:

- **copy startup-config tftp** <tftp-ip-addr> <filename> – Use this command to upload a copy of startup-config from the BigIron RX Series to a TFTP server.
- **copy running-config tftp** <tftp-ip-addr> <filename> – Use this command to upload a copy of the running configuration from the BigIron RX Series to a TFTP server.
- **copy tftp startup-config** <tftp-ip-addr> <filename> – Use this command to download a copy of the startup-config from a TFTP server to a switch.
- **copy tftp running-config** <tftp-ip-addr> <filename> [**overwrite**] – Use this command to download the running configuration from the system's runtime memory to a TFTP server. The running configuration is then appended to the current configuration of a BigIron RX Series.

## Making local copies of the startup configuration file

You can copy the startup-config file in code flash to another location in code flash or to a PCMCIA flash card inserted in a the management module's slot 1 or 2.

For example, to make a backup copy of the startup-config file and save the backup file in code flash, enter a command such as the following at the Privileged EXEC level in the CLI:

```
BigIron RX# cp startup-config startup-config.bak
```

**Syntax:** cp <source-file-name> <dest-file-name>

For example, to make a backup copy of the startup-config file and save the backup file on a flash card in slot 2, enter a command such as the following at the Privileged EXEC level in the CLI:

```
BigIron RX# cp startup-config /slot2/backups/startup-config.bak
```

**Syntax:** cp [/<source-dir-path>]/<source-file-name> [/<dest-dir-path>]/<dest-file-name>

---

### NOTE

These example assume that code flash has the current management focus.

---

Specify the <source-dir-path> parameter if the source file is in a file system that does not have current management focus. The <source-file-name> specifies the name of the file you want to copy.

Specify the <dest-dir-path> parameter if you want to copy the source file to a file system that does not have current management focus. The <dest-file-name> specifies the name of the file you copied to a new destination.

## Dynamic configuration loading

You can load dynamic configuration commands (commands that do not require a reload to take effect) from a file on a TFTP server into the BigIron RX Series switch's running-config. You can make configuration changes off-line, then load the changes directly into the device's running-config, without reloading the software.

### *Usage considerations*

- Use this feature only to load configuration information that does not require a software reload to take effect. For example, you cannot use this feature to change statically configured memory (**system-max** command).
- Do not load port configuration information for secondary ports in a trunk group. Since all ports in a trunk group use the port configuration settings of the primary port in the group, the software cannot implement the changes to the secondary port.

### *Preparing the configuration file*

A configuration file that you create must follow the same syntax rules as the startup-config file the device creates.

- The configuration file is a script containing CLI configuration commands. The CLI reacts to each command entered from the file in the same way the CLI reacts to the command if you enter it. For example, if the command results in an error message or a change to the CLI configuration level, the software responds by displaying the message or changing the CLI level.
- The software retains the running-config that is currently on the device, and changes the running-config only by adding new commands from the configuration file. If the running config already contains a command that is also in the configuration file you are loading, the CLI rejects the new command as a duplicate and displays an error message. For example, if the running-config already contains a command that configures ACL 1, the software rejects ACL 1 in the configuration file, and displays a message that ACL 1 is already configured.
- The file can contain global CONFIG commands or configuration commands for interfaces, routing protocols, and so on. You cannot enter User EXEC or Privileged EXEC commands.
- The default CLI configuration level in a configuration file is the global CONFIG level. Thus, the first command in the file must be a global CONFIG command or “!”. The ! (exclamation point) character means “return to the global CONFIG level”.

---

#### **NOTE**

You can enter text following “!” as a comment. However, the “!” is not a comment marker. It returns the CLI to the global configuration level.

---

---

#### **NOTE**

The CLI changes to the global CONFIG level if you load the configuration as a startup-config file instead of the running-config (using the **copy tftp startup-config** <ip-addr> <filename> command or **ncopy tftp** <ip-addr> <from-name> **startup-config** command).

---

---

#### **NOTE**

If you copy-and-paste a configuration into a management session, the CLI ignores the “!” instead of changing the CLI to the global CONFIG level. As a result, you might get different results if you copy-and-paste a configuration instead of loading the configuration using TFTP.

---

- Make sure you enter each command at the correct CLI level. Since some commands have identical forms at both the global CONFIG level and individual configuration levels, if the CLI’s response to the configuration file results in the CLI entering a configuration level you did not intend, then you can get unexpected results.

For example, if a trunk group is active on the device, and the configuration file contains a command to disable STP on one of the secondary ports in the trunk group, the CLI rejects the



commands to enter the interface configuration level for the port and moves on to the next command in the file you are loading. If the next command is a spanning-tree command whose syntax is valid at the global CONFIG level as well as the interface configuration level, then the software applies the command globally. Here is an example:

The configuration file contains these commands:

```
interface ethernet 4/2
no spanning-tree
```

The CLI responds like this:

```
BigIron RX(config)# interface ethernet 4/2
Error - cannot configure secondary ports of a trunk
BigIron RX(config)# no spanning-tree
BigIron RX(config)#
```

- If the file contains commands that must be entered in a specific order, the commands must appear in the file in the required order. For example, if you want to use the file to replace an IP address on an interface, you must first remove the old address using “no” in front of the **ip address** command, then add the new address. Otherwise, the CLI displays an error message and does not implement the command. Here is an example:

The configuration file contains these commands:

```
interface ethernet 3/1
ip address 10.10.10.1/24
```

The running-config already has a command to add an address to 3/1, so the CLI responds like this:

```
BigIron RX(config)# interface ethernet 3/1
BigIron RX(config-if-e1000-3/1)# ip add 10.10.10.69/24
Error: can only assign one primary ip address per subnet
BigIron RX(config-if-e1000-3/1)#
```

To successfully replace the address, enter commands into the file as follows:

```
interface ethernet 3/1
no ip address 10.10.10.1/24
ip address 10.10.10.69/24
```

This time, the CLI accepts the command, and no error message is displayed:

```
BigIron RX(config)# interface ethernet 3/1
BigIron RX(config-if-e1000-3/1)# no ip add 10.10.10.1/24
BigIron RX(config-if-e1000-3/1)# ip add 10.10.10.69/24
BigIron RX-if-e1000-3/1)
```

- Always use the **end** command at the end of the file. The **end** command must appear on the last line of the file, by itself.

## Loading the configuration information into the running-config

You can load the configuration information from a TFTP server. To load the file from a TFTP server, use either of the following commands:

- **copy tftp running-config** <ip-addr> <filename> [overwrite]
- **ncopy tftp** <ip-addr> <filename> **running-config**

## Using SNMP to save and load configuration information

You can use a third-party SNMP management application such as HP OpenView to save and load a BigIron RX Series switch's configuration. Follow the steps given below to save and load configuration information using HP OpenView.

---

### NOTE

The syntax shown in this section assumes that you have installed HP OpenView in the "/usr" directory.

---

1. Configure a read-write community string on the Brocade device, if one is not already configured. To configure a read-write community string, enter the following command from the global CONFIG level of the CLI:

```
snmp-server community <string> ro | rw
```

where <string> is the community string and can be up to 32 characters long.

2. On the Brocade device, enter the following command from the global CONFIG level of the CLI:

```
no snmp-server pw-check
```

This command disables password checking for SNMP set requests. If a third-party SNMP management application does not add a password to the password field when it sends SNMP set requests to a Brocade device, by default the Brocade device rejects the request.

3. From the command prompt in the UNIX shell, enter the following command:

```
/usr/OV/bin/snmpset -c <rw-community-string> <-ip-addr> 1.3.6.1.4.1.1991.1.1.2.1.5.0  
ipaddress <tftp-ip-addr> 1.3.6.1.4.1.1991.1.1.2.1.8.0 octetstringascii <config-file-name>  
1.3.6.1.4.1.1991.1.1.2.1.9.0 integer <command-integer>
```

where:

<rw-community-string> is a read-write community string configured on the Brocade device.

<fdry-ip-addr> is the Brocade device's IP address.

<tftp-ip-addr> is the TFTP server's IP address.

<config-file-name> is the configuration file name.

<command-integer> is one of the following:

**20** – Upload the startup-config file from the Brocade device's code flash to the TFTP server.

**21** – Download a startup-config file from a TFTP server to the Brocade device's code flash.

**22** – Upload the running-config from the Brocade device's code flash to the TFTP server.

**23** – Download a configuration file from a TFTP server into the Brocade device's running-config.

---

**NOTE**

Command option **23** adds configuration information to the running-config on the device, and does not replace commands. If you want to replace configuration information in the device, use “no” forms of the configuration commands to remove the configuration information, then use configuration commands to create the configuration information you want.

---

## Erasing image and configuration files

To erase software images or configuration files, use the commands described below. These commands are valid at the Privileged EXEC level of the CLI:

- **erase flash primary** erases the image stored in primary flash of the system.
- **erase flash secondary** erases the image stored in secondary flash of the system.
- **erase startup-config** erases the configuration stored in the startup configuration file; however, the running configuration remains intact until system reboot.

## File synchronization

This section provides details for synchronizing the files on the management and interface modules.

### File synchronization between the active and standby management modules

Each active and standby management module contains the following files that can be synchronized between the two modules:

- Flash code – The flash code can include the following files:
  - monitor, which contains the management module’s Real Time Operating System (RTOS).
  - primary, which contains the management module’s primary IronWare image.
  - secondary, which contains the management module’s secondary IronWare image.

(An IronWare image contains the layer 1 – 3 software run by the management module.) During startup or switchover, the active module compares the standby module’s flash code to its own. If differences exist, the active module synchronizes the standby module’s flash code with its own. If you update the flash code on the active module, the active module automatically synchronizes (without comparison) the standby module’s flash code with its own.

- System-config file – The flash code also includes the system-config file. During startup or switchover, the active module compares the standby module’s system-config file to its own. If differences exist, the active module synchronizes the standby module’s system-config file with its own. When you save changes to the system-config file on the active module, the active module automatically synchronizes (without comparison) the standby module’s system-config file with its own.
- Running-config – The running-config file resides in the BigIron RX Series system memory.

The BigIron RX Series switches allow you to do the following related to file synchronization:

- Compare files on the active module with files on the standby module and immediately synchronize any files that are different.

- Immediately synchronize all files between the active and standby modules.
- Change the default automatic synchronization interval for the running-config file.

The following sections explain how to perform these tasks.

### *Comparing and synchronizing files*

You can initiate a comparison of the flash code, system-config file, and running-config file on the active management module with the same files on the standby module and synchronize the files immediately if differences exist. When you synchronize the files, the active module copies its files to the standby module, replacing the files on the standby module.

To compare and immediately synchronize files between the active and standby modules if differences exist, enter the following command at the Privileged EXEC level of the CLI:

```
BigIron RX# sync-standby
```

**Syntax:** sync-standby

### *Synchronizing files without comparison*

You can synchronize the flash code, system-config file, and running-config file immediately without comparison. When you synchronize the files, the active module copies its files to the standby module, replacing the files on the standby module.

To immediately synchronize the files between the active and standby modules, enter the following command at the Privileged EXEC level of the CLI:

```
BigIron RX# force-sync-standby
```

**Syntax:** force-sync-standby

## File synchronization between the management and interface modules

An interface module can have two IronWare images: primary and secondary. These images contain the layer 1 – 3 software that the interface modules run. These images reside in the interface module's flash memory. Either the primary or secondary image is run by the interface module from this location.

If you copy the primary or secondary IronWare image to all interface modules using the **copy** command with the **all** keyword, the management module makes a copy of the file and stores it in its code flash under the names lp-primary-0 or lp-secondary-0. The images are stored in this location only and are not run by the management module or the interface modules. If you copy the primary or secondary IronWare image to a specified chassis slot using the **copy** command with the <chassis-slot-number> parameter, the management module does not make a copy of the file.

If the management module has a copy of the primary or secondary IronWare image in its code flash, by default, the BigIron RX Series system synchronizes or prompts you to synchronize the interface modules IronWare images between the management module and the interface modules during bootup. When the BigIron RX Series synchronizes the IronWare images, the management module copies the IronWare images from its code flash to the interface modules' code flash (the interface modules' default boot source).

The system allows you to manage synchronization of the IronWare images between management and interface modules in the following situations:

- You are prompted to synchronize the IronWare images during bootup.

- You want to initiate an immediate synchronization; for example, you want an immediate update of the IronWare images on one or all interface modules.
- You want to disable synchronization; for example, you have upgraded the IronWare image of one interface module but want to continue running the older image on all other interface modules.

The following section discuss how to manage the IronWare image synchronization in these situations.

### *Synchronizing the interface modules IronWare images during bootup*

By default, the BigIron RX Series checks the IronWare images in the interface module's flash memory during boot to ensure they are is the same as the IronWare images in the management module's flash memory. If an interface module does not have an IronWare image, the system automatically downloads the image from the management module's flash memory to the interface module's flash memory.

If an interface module has different IronWare images, the system prompts you to do the following:

- If you want to update the primary and secondary IronWare images in the interface module's flash memory with the images in the management module's flash memory, enter the **lp cont-boot sync <slot-number>** command at the Privileged EXEC prompt.
- If you want to retain the IronWare images in the interface module's flash memory, enter the **lp cont-boot no-sync <slot-number>** command at the Privileged EXEC prompt.

### *Specifying an immediate synchronization*

You can immediately synchronize the IronWare images between the management module and one or all interface modules. For example, to immediately synchronize the IronWare images between the management module and all interface modules, enter the following command at the Privileged EXEC level:

```
BigIron RX# lp sync all
```

**Syntax:** lp sync all | <slot-number>

The **all** keyword indicates that the immediate synchronization applies to all interface modules in the BigIron RX Series.

The <slot-number> parameter specifies the BigIron RX Series slot number that contains the interface module to which the immediate synchronization applies. You can specify 1 – 16.

### *Disabling or re-enabling an automatic check and synchronization*

By default, the BigIron RX Series checks the IronWare images in the interface module's flash memory during bootup to ensure it is the same as the IronWare images in the management module's flash memory. For information about what the system does if the interface module does not currently have a IronWare image or if the image is different from that of the management module, refer to [“Synchronizing the interface modules IronWare images during bootup”](#) on page 197.

To disable the automatic check and synchronization during bootup, enter the following command at the global CONFIG level:

```
BigIron RX(config)# lp disable-lp-sync-check
```

**Syntax:** lp disable-lp-sync-check

Provided that you save this configuration by entering the **write memory** command, the system will disable the automatic check and synchronization of the IronWare images starting with the next software reload or system reset and each reload or reset after that.

To re-enable the automatic check and synchronization of the IronWare images during bootup, enter the following command at the global CONFIG level:

```
BigIron RX(config)# no lp disable-lp-sync-check
```

**Syntax:** no lp disable-lp-sync-check

## Scheduling a system reload

In addition to reloading the BigIron RX Series system manually, you can configure the system to reload itself at a specific time or after a specific amount of time has passed.

---

### NOTE

The scheduled reload feature requires the system clock. You can use a Simple Network Time Protocol (SNTP) server to set the clock or you can set the device clock manually.

---

### Reloading at a specific time

To schedule a system reload for a specific time, use one of the following methods.

To schedule a system reload from the primary flash module for 6:00:00 AM, January 19, 2004, enter the following command at the Privileged EXEC level of the CLI:

```
BigIron RX# reload at 06:00:00 01-19-04
```

**Syntax:** reload at <hh:mm:ss> <mm-dd-yy> [primary | secondary]

<hh:mm:ss> is the hours, minutes, and seconds.

<mm-dd-yy> is the month, day, and year.

**primary | secondary** specifies whether the reload is to occur from the primary code flash module or the secondary code flash module. The default is **primary**.

### Reloading after a specific amount of time

To schedule a system reload to occur after a specific amount of time has passed on the system clock, use one of the following methods.

To schedule a system reload from the secondary flash one day and 12 hours later, enter the following command at the Privileged EXEC level of the CLI:

```
BigIron RX# reload after 01:12:00 secondary
```

**Syntax:** reload after <dd:hh:mm> [primary | secondary]

<dd:hh:mm> is the number of days, hours, and minutes.

**primary | secondary** specifies whether the reload is to occur from the primary code flash module or the secondary code flash module.

## Displaying the amount of time remaining before a scheduled reload

To display how much time is remaining before a scheduled system reload takes place, use one of the following methods.

To display how much time is remaining before a scheduled system reload, enter the following command from any level of the CLI:

```
BigIron RX# show reload
```

## Canceling a scheduled reload

To cancel a scheduled system reload, enter the following command at the Privileged EXEC level of the CLI:

```
BigIron RX# reload cancel
```

# Diagnostic error codes and remedies for TFTP transfers

If an error occurs with a TFTP transfer to or from a BigIron RX Series switch, one of the following error codes are displayed.

**TABLE 30** Diagnostic error codes

| Error code | Message                         | Explanation and action                                                                                                                                                                                                                                                                                                                                                                                                          |
|------------|---------------------------------|---------------------------------------------------------------------------------------------------------------------------------------------------------------------------------------------------------------------------------------------------------------------------------------------------------------------------------------------------------------------------------------------------------------------------------|
| 1          | Flash read preparation failed.  | A flash error occurred during the download.                                                                                                                                                                                                                                                                                                                                                                                     |
| 2          | Flash read failed.              | Retry the download. If it fails again, contact customer support                                                                                                                                                                                                                                                                                                                                                                 |
| 3          | Flash write preparation failed. |                                                                                                                                                                                                                                                                                                                                                                                                                                 |
| 4          | Flash write failed.             |                                                                                                                                                                                                                                                                                                                                                                                                                                 |
| 5          | TFTP session timeout.           | TFTP failed because of a time out.<br>Check IP connectivity and make sure the TFTP server is running.                                                                                                                                                                                                                                                                                                                           |
| 6          | TFTP out of buffer space.       | The file is larger than the amount of space on the device or TFTP server.<br>If you are copying an image file to flash, first copy the other image to your TFTP server, then delete it from flash. (Use the <b>erase flash...</b> CLI command at the Privileged EXEC level to erase the image in the flash.)<br>If you are copying a configuration file to flash, edit the file to remove unneeded information, then try again. |

## 7 Diagnostic error codes and remedies for TFTP transfers

**TABLE 30** Diagnostic error codes (Continued)

| Error code | Message                                         | Explanation and action                                                                                                   |
|------------|-------------------------------------------------|--------------------------------------------------------------------------------------------------------------------------|
| 7          | TFTP busy, only one TFTP session can be active. | Another TFTP transfer is active on another CLI session, SNMP, or Web management session. Wait, then retry the transfer.  |
| 8          | File type check failed.                         | You accidentally attempted to copy the incorrect image code into the system. Retry the transfer using the correct image. |
| 16         | TFTP remote - general error.                    | The TFTP configuration has an error. The specific error message describes the error.                                     |
| 17         | TFTP remote - no such file.                     | Correct the error, then retry the transfer.                                                                              |
| 18         | TFTP remote - access violation.                 |                                                                                                                          |
| 19         | TFTP remote - disk full.                        |                                                                                                                          |
| 20         | TFTP remote - illegal operation.                |                                                                                                                          |
| 21         | TFTP remote - unknown transfer ID.              |                                                                                                                          |
| 22         | TFTP remote - file already exists.              |                                                                                                                          |
| 23         | TFTP remote - no such user.                     |                                                                                                                          |



# Hardware Specifications

---

## In this chapter

- [Hardware specifications](#) ..... 201
- [Port specifications](#) ..... 205

## Hardware specifications

This section contains hardware specifications for the BigIron RX Series chassis:

### Power specifications

This section contains the power specifications for the BigIron RX Series chassis.

The power supply frequency requirements for the BigIron RX -4, -8, and -16 chassis are as follows:

- AC Input Rating: 100 -240V, 50/60 Hz, 16.0 A Max Per Power Supply
  - AC Operating Voltage Range: 90 - 264V, 50/60 Hz
- DC Input Rating: -48V, 30.0 A Max Per Power Supply
  - DC Operating Range: -40 to -60 vdc

The power supply frequency requirements for the BigIron RX -32 chassis are as follows:

- AC Input Rating: 200 -240V, 50/60 Hz, 16.0 A Max Per Power Supply
- DC Input Rating: -48V, 60.0 A Max Per Power Supply
  - DC Operating Range: -40 to -60V

[Table 31](#) and [Table 32](#) provide the maximum power calculations for the BigIron RX Series chassis.

**TABLE 31** Maximum power calculations @ 100 VAC

| BigIron RX Series chassis | Current Amps | Watts | BTU per hour |
|---------------------------|--------------|-------|--------------|
| BigIron RX-4              | 12           | 1217  | 4155         |
| BigIron RX-8              | 24           | 2417  | 8249         |
| BigIron RX-16             | 49           | 4905  | 16741        |
| BigIron RX-32             | N/A          | N/A   | N/A          |

**TABLE 32 Maximum power calculations @ 200 VAC**

| BigIron RX Series chassis | Current Amps | Watts | BTU per hour |
|---------------------------|--------------|-------|--------------|
| BigIron RX-4              | 6            | 1217  | 4155         |
| BigIron RX-8              | 12           | 2417  | 8249         |
| BigIron RX-16             | 25           | 4905  | 16741        |
| BigIron RX-32             | 57           | 11353 | 38746        |

**TABLE 33 Maximum power calculations at 48 VDC**

| BigIron RX Series chassis | Amps | Watts | BTUs per hour |
|---------------------------|------|-------|---------------|
| BigIron RX-4              | 25   | 1217  | 4155          |
| BigIron RX-8              | 50   | 2417  | 8249          |
| BigIron RX-16             | 102  | 4905  | 16741         |
| BigIron RX-32             | N/A  | N/A   | N/A           |

Table 34 lists the maximum power consumption, in watts, for BigIron RX Series modules.

**TABLE 34 Wattage consumed by individual components**

| Component                                                                   | Maximum power consumption, in Watts |
|-----------------------------------------------------------------------------|-------------------------------------|
| <b>Management modules</b>                                                   |                                     |
| Management (BigIron RX-4, -8, and -16)                                      | 30W                                 |
| Management (BigIron RX-32)                                                  | 35W                                 |
| <b>Switch fabric</b>                                                        |                                     |
| RX-BI-SFM1 (BigIron RX-4, -8, and -16)                                      | 19W                                 |
| RX-BI-SFM3 (BigIron RX-4, -8, and -16)                                      | 53W                                 |
| RX-BI-32-SFM (BigIron RX-32)                                                | 200W                                |
| <b>Interface modules</b>                                                    |                                     |
| 4-port 10 Gigabit Ethernet interface with fiber-optic modules installed     | 191W                                |
| 2-port 10 Gigabit Ethernet interface with fiber-optic modules installed     | 110W                                |
| 24-port Gigabit Ethernet Fiber Interface with fiber-optic modules installed | 101W                                |
| 24-port Gigabit Ethernet Copper Interface                                   | 102W                                |
| 48-port Gigabit Ethernet Copper Interface                                   | 210W                                |
| 16-port 10 Gigabit Ethernet Interface                                       | 245W                                |

**TABLE 34** Wattage consumed by individual components (Continued)

| Component                                                                                | Maximum power consumption, in Watts |
|------------------------------------------------------------------------------------------|-------------------------------------|
| <b>Fans</b>                                                                              |                                     |
| BigIron RX-4 Fan Tray                                                                    | 66W                                 |
| BigIron RX-8 Fan Tray                                                                    | 132W                                |
| BigIron RX-16 Front Fan Tray                                                             | 202W                                |
| BigIron RX-16 Rear Fan Module (2 are required)                                           | 144W                                |
| BigIron RX-32 Fan Modules (8 cooling interface fans, 2 power supply fans, all inclusive) | 1150W                               |

**NOTE**

The maximum power consumption table reflects the measured maximum power consumption of different line card types. The chassis, cooling system, power distribution, as well as the algorithm used in the system software for determining the power requirements are based on a conservative requirement of 245W per line card, regardless of the actual mix of line cards types in a given chassis.

**NOTE**

The DC input PSU has a -40VDC to -60VDC operating range with -48VDC as the nominal input voltage.

## Physical dimensions

Table 35 provides the physical dimensions for the BigIron RX Series chassis.

**TABLE 35** BigIron RX Series physical dimensions

| BigIron RX Series chassis | Height               | Width               | Depth               | Weight (fully loaded)      |
|---------------------------|----------------------|---------------------|---------------------|----------------------------|
| BigIron RX-4              | 17.7 cm (6.96 in.)   | 44.3 cm (17.45 in.) | 52.1 cm (20.53 in.) | 35 kg (78 lbs)             |
| BigIron RX-8              | 31 cm (12.21 in.)    | 44.3 cm (17.45 in.) | 53.3 cm (21 in.)    | 60 kg (131 lbs)            |
| BigIron RX-16             | 62.2 cm (24.47 in.)  | 43.7 cm (17.2 in.)  | 63.5 cm (25 in.)    | 107 kg (236 lbs)           |
| BigIron RX-32             | 146.4 cm (57.64 in.) | 44.3 cm (17.45 in.) | 71.7 cm (28.22 in.) | approx. 255 kg (561 lbs) * |

\* 362 lbs (164 kg) for a chassis loaded with blanks, with no power supplies, management modules, switch fabric modules, nor interface modules.

## Operating environment

Table 36 provides the operating environment specifications for the BigIron RX Series chassis.

**TABLE 36** BigIron RX Series operating environment

| Operating temperature     | Relative humidity                           | Operating altitude            |
|---------------------------|---------------------------------------------|-------------------------------|
| 0° - 40° C (32° - 104° F) | 5 to 90%, at 40° C (104° F), non-condensing | 0 - 2012 meters (0 - 6600 ft) |

## Storage environment

Table 37 provides the storage environment specifications for the BigIron RX Series chassis.

**TABLE 37** BigIron RX series storage environment

| Storage temperature          | Storage humidity                              | Storage altitude                 |
|------------------------------|-----------------------------------------------|----------------------------------|
| -25° - 70° C (-13° - 158° F) | 95% maximum relative humidity, non-condensing | (0 - 4500 meters (0 - 15,000 ft) |

## Safety agency approvals

- CAN/CSA-C22.2 No. 60950-1-03/UL60950-1 – Third Edition, Safety of Information Technology Equipment
- EN 60825-1 Safety of Laser Products – Part 1: Equipment Classification, Requirements and User's Guide
- EN 60825-2 Safety of Laser Products – Part 2: Safety of Optical Fibre Communications Systems
- EN 60950-1:2001\IEC 60950-1 Safety of Information Technology Equipment

## Electromagnetic approvals

- FCC Part 15, Subpart B (Class A)
- EN 55022 (CE mark) (Class A)
- EN55024 (CE mark) (Immunity) for Information Technology Equipment
- ICES-003 Emission Certification (Interference Causing Equipment Standard) (Canada) (Class A)
- AS/NZ 55022 (Australia) (Class A)
- VCCI (Japan) (Class A)
- EN 61000-3-2
- EN 61000-3-3
- EN 61000-6-1

## Port specifications

This section provides pin assignments for the following ports:

- Management module's Console port (serial connector)
- Management module's management port (RJ-45 unshielded twisted pair (UTP) connector)

### Console port pin assignments

The Console port is a standard male DB-9 connector, as shown in [Figure 90](#). For information about how you can use this port, refer to “[Console port](#)” on page 9.

**FIGURE 90** Console port pin and signalling details

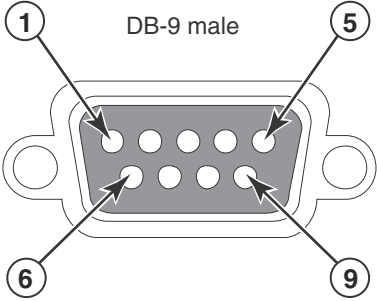
| Pin Assignment                                                                     | Pin Number | Switch Signal |
|------------------------------------------------------------------------------------|------------|---------------|
|  | 1          | Reserved      |
|                                                                                    | 2          | TXD (output)  |
|                                                                                    | 3          | RXD (input)   |
|                                                                                    | 4          | Reserved      |
|                                                                                    | 5          | GND           |
|                                                                                    | 6          | Reserved      |
|                                                                                    | 7          | CTS (input)   |
|                                                                                    | 8          | RTS (output)  |
|                                                                                    | 9          | Reserved      |

Most PC serial ports require a cable with a female DB-9 connector. However, terminal connections will vary, requiring a cable with either a DB-9 or DB-25 connector, male or female.

Serial cable options between the BigIron RX Series chassis and a PC or terminal are shown in [Figure 91](#).

#### NOTE

As indicated in [Figure 90](#) and [Figure 91](#), some of the wires should not be connected. If you do connect the wires that are labeled “Reserved”, you might get unexpected results with some terminals.

**FIGURE 91** Console port pin assignments showing cable connection options to a terminal or PC

| DB-9 to DB-9<br>Female Switch |          |   | Terminal or PC | DB-9 to DB-25<br>Female Switch |          |    | Terminal or PC |
|-------------------------------|----------|---|----------------|--------------------------------|----------|----|----------------|
| 1                             | Reserved |   | 1              | 1                              | Reserved | 8  |                |
| 2                             |          | → | 2              | 2                              |          | 3  |                |
| 3                             |          | ← | 3              | 3                              |          | 2  |                |
| 4                             | Reserved |   | 4              | 4                              | Reserved | 20 |                |
| 5                             |          |   | 5              | 5                              |          | 7  |                |
| 6                             | Reserved |   | 6              | 6                              | Reserved | 6  |                |
| 7                             |          | ← | 7              | 7                              |          | 4  |                |
| 8                             |          | → | 8              | 8                              |          | 5  |                |
| 9                             | Reserved |   | 9              | 9                              | Reserved | 22 |                |

## Management port pin assignments

The management port is an RJ-45 UTP connector. [Table 38](#) describes the connector’s pin assignments. For information about how you can use this port, refer to “[10/100/1000 Ethernet port](#)” on page 9.

**TABLE 38** Management port pin assignments

| Pin number | MDI-X ports                           |
|------------|---------------------------------------|
| 1          | TD+                                   |
| 2          | TD-                                   |
| 3          | RD+                                   |
| 4          | Not used (10BaseT)<br>CMT (100BaseTX) |
| 5          | Not used (10BaseT)<br>CMT (100BaseTX) |
| 6          | RD-                                   |
| 7          | Not used (10BaseT)<br>CMT (100BaseTX) |
| 8          | Not used (10BaseT)<br>CMT (100BaseTX) |

# Regulatory Statements

---

## U.S.A.

This equipment has been tested and found to comply with the limits for a Class A digital device pursuant to Part 15 of the FCC Rules. These limits are designed to provide reasonable protection against harmful interference when the equipment is operated in a commercial environment. This equipment generates, uses, and can radiate radio frequency energy and, if not installed and used in accordance with the instruction manual, may cause harmful interference to radio communications. Operation of this equipment in a residential area is likely to cause harmful interference in which case the user will be required to correct the interference at his own expense.

## Industry Canada statement

This Class A digital apparatus complies with Canadian ICES-003.

Cet appareil numérique de la classe A est conforme à la norme NMB-003 du Canada.

## Europe and Australia

This is a Class A product. In a domestic environment this product may cause radio interference in which case the user may be required to take adequate measures.

## Japan

この装置は、情報処理装置等電波障害自主規制協議会（VCCI）の基準に基づくクラス A 情報技術装置です。この装置を家庭環境で使用すると電波妨害を引き起こすことがあります。この場合には使用者が適切な対策を講ずるよう要求されることがあります。

### English translation of above statement

This is Class A product based on the standard of the Voluntary Control Council For Interference by Information Technology Equipment (VCCI). If this equipment is used in a domestic environment, radio disturbance may arise. When such trouble occurs, the user may be required to take corrective actions.

## Korea

이 기기는 A급 기기로서, 업무용으로 전자파 적합 등록을 한 기기이오니 판매자 또는 사용자는 이 점을 유의하시기 바라며, 만약 잘못 판매 또는 구입하였을 경우에는 가정용으로 교환하시기 바랍니다.

### **English translation of above statement**

This apparatus has radio wave acceptability registration as a Class A device, so sellers or users should be aware of this. If it is sold or purchased incorrectly, it should be exchanged with a home apparatus (Class B).



# Caution and Danger Notices

---

## Caution statements

The cautions and danger notices that appear in this manual are listed below in English, German, French, and Spanish.

A caution calls your attention to a possible hazard that can damage equipment.

"Vorsicht" weist auf eine mögliche Beschädigung des Geräts hin. Sie finden die folgenden Vorsichtshinweise in diesem Handbuch.

Une mise en garde attire votre attention sur un risque possible d'endommagement de l'équipement. Ci-dessous, vous trouverez les mises en garde utilisées dans ce manuel.

Un mensaje de precaución le advierte sobre un posible peligro que pueda dañar el equipo. Las siguientes son precauciones utilizadas en este manual.

|               |                                                                                                                                                                                                                                                                                                                                                                                                                                                               |
|---------------|---------------------------------------------------------------------------------------------------------------------------------------------------------------------------------------------------------------------------------------------------------------------------------------------------------------------------------------------------------------------------------------------------------------------------------------------------------------|
| CAUTION       | All devices with DC power supplies (BigIron RX-4, -8, and -16) are intended for installation in restricted access areas only. A restricted access area is where access can be gained only by service personnel through the use of a special tool, lock and key, or other means of security, and is controlled by the authority responsible for the location.                                                                                                  |
| VORSICHT      | Alle Geräte mit Direktstromquellen (BigIron RX-4, -8, and -16) sind nur zur Installation in Sperrbereichen bestimmt. Ein Sperrbereich ist ein Ort, zu dem nur Wartungspersonal mit einem Spezialwerkzeug, Schloss und Schlüssel oder einer anderen Schutzvorrichtung Zugang hat. Er unterliegt außerdem der Kontrolle durch die für den Standort verantwortliche Stelle.                                                                                      |
| MISE EN GARDE | Tous les équipements dotés d'un bloc d'alimentation en courant continu (BigIron RX-4, BigIron RX-8 et BigIron RX-16) sont conçus pour l'installation dans des zones à accès réglementé uniquement. Une zone à accès réglementé est un local qui n'est accessible que par le personnel d'entretien à l'aide d'un outil, verrou ou clé conçus à cet effet, ou de tout autre accessoire de sécurité, et qui est contrôlé par l'autorité responsable de ce local. |
| PRECAUCIÓN    | Todos aquellos dispositivos con fuentes de alimentación de CC (BigIron RX-4, -8, y -16) están diseñados para su instalación en zonas de acceso restringido solamente. Una zona de acceso restringido es un lugar al que sólo puede acceder personal de mantenimiento haciendo uso de una herramienta especial, una llave y un candado, o algún otro medio de seguridad, y que está controlado por la autoridad responsable.                                   |

## B Caution statements

|               |                                                                                                                                                                                                                                                                                                                                                                                                                                                                                                                                                                                                                                                                                                                                                                                                                                                                           |
|---------------|---------------------------------------------------------------------------------------------------------------------------------------------------------------------------------------------------------------------------------------------------------------------------------------------------------------------------------------------------------------------------------------------------------------------------------------------------------------------------------------------------------------------------------------------------------------------------------------------------------------------------------------------------------------------------------------------------------------------------------------------------------------------------------------------------------------------------------------------------------------------------|
| CAUTION       | For a DC system (BigIron RX-4, -8, and -16), use a grounding wire of at least 6 American Wire Gauge (AWG). The 6 AWG wire should be attached to an agency-approved crimp connector (provided on the BigIron RX-16 chassis), crimped with the proper tool. The crimp connector should allow for securement to both ground screws on the enclosure. For the BigIron RX-8 and BigIron RX-4, use a grounding wire of at least 6 American Wire Gauge (AWG). For the ground lug use a UL-listed Panduit crimp connector, P/N LCD6-10A, and two 10-32, PPH, 1/2 screws to secure crimp connector to chassis. The grounding position is located on the side of the chassis adjacent to the ground symbol.                                                                                                                                                                         |
| VORSICHT      | Für ein Gleichstromsystem (BigIron RX-4, -8 und -16) ist ein Erdleiter von mindestens 6 AWG (amerikanische Norm für Drahtquerschnitte) zu verwenden. Der 6-AWG-Leiter sollte an einem geprüften gecrimpten Anschluss (am BigIron RX-16 Chassis bereitgestellt) angebracht und mit dem vorschriftsmäßigen Werkzeug gecrimpt werden. Der gecrimpte Anschluss sollte eine Sicherung an beiden Erdungsschrauben am Gehäuse ermöglichen. Für BigIron RX-8 und BigIron RX-4 ist ein Erdleiter von mindestens 6 AWG (American Wire Gauge) zu verwenden. Für den Erdungskabelschuh ist ein UL-geprüfter Panduit-Crimp-Anschluss (Best.-Nr. LCD6-10A) und zwei 10-32, PPH, 1/2-Schrauben zur Sicherung des Crimp-Anschlusses am Chassis zu verwenden. Die Erdungsposition befindet sich seitlich am Chassis neben dem Erdungssymbol.                                               |
| MISE EN GARDE | Pour un système à alimentation continue (BigIron RX-4, -8 et -16), utiliser un câble de mise à la terre de calibre AWG 6 (13 mm <sup>2</sup> ) au minimum. Le conducteur de 13 mm <sup>2</sup> doit être fixé à un raccord à sertir agréé (directement présent sur le châssis du BigIron RX-16) à l'aide de la pince à sertir appropriée. Le raccord à sertir doit pouvoir être raccordé aux deux vis de mise à la terre du châssis. Pour les BigIron RX-8 et BigIron RX-4, utiliser un câble de mise à la terre de calibre AWG 6 (13 mm <sup>2</sup> ) au minimum. Pour la borne de mise à la terre, utiliser un raccord à sertir Panduit agréé (réf. LCD6-10A). Pour fixer ce raccord au châssis, utiliser deux 1/2 vis 10-32 PPH. L'emplacement prévu pour la mise à la terre, identifié par le symbole international correspondant, se trouve sur le côté du châssis. |
| PRECAUCIÓN    | Para un sistema de CC (BigIron RX-4, -8, y -16), utilice un conductor de tierra de al menos 6 CAE (Calibre de Alambre Estadounidense, American Wire Gauge o AWG en sus siglas en inglés). El conductor de 6 CAE debe estar acoplado a un conector rizado homologado (suministrado con el chasis BigIron RX-16), que haya sido rizado con la herramienta apropiada. El conector rizado debe permitir el acoplamiento a los dos tornillos de tierra del recinto. Para los sistemas BigIron RX-8 y BigIron RX-4, utilice un conductor de tierra de al menos 6 CAE. Para el terminal de tierra, utilice un conector rizado Panduit homologado por UL, P/N LCD6-10A, y dos tornillos 1/2, PPH, 10-32 para fijar el conector rizado al chasis. La posición de conexión a tierra está situada en el lateral del chasis junto al símbolo de tierra.                               |
| CAUTION       | If the wall outlet is not rated 115/120V and 20A, you must have an electrician rewire the outlet and power source. Make sure you obtain a power cord displaying the mark of the safety agency that defines the regulations for power cords in your country. The mark is your assurance that the power cord can be used safely with the device.                                                                                                                                                                                                                                                                                                                                                                                                                                                                                                                            |

|               |                                                                                                                                                                                                                                                                                                                                                                                                   |
|---------------|---------------------------------------------------------------------------------------------------------------------------------------------------------------------------------------------------------------------------------------------------------------------------------------------------------------------------------------------------------------------------------------------------|
| CAUTION       | For the DC input circuit to the system (BigIron RX-4, -8, and -16), make sure there is a 30 amp circuit breaker, minimum -48Vdc, double pole, on the input to the terminal block. The input wiring for connection to the product should be copper wire, 8 AWG, marked VW-1, and rated minimum 90 degrees Celcius.                                                                                 |
| VORSICHT      | Für den Eingangs-Gleichstromkreis zum System (BigIron RX-4, -8, and -16) ist ein 30 A (Minimum), -48 V DC, doppelpolig, am Eingang zur Reihenklemme zu installieren. Bei der Eingangsverdrahtung zum Anschluss des Produkts sollte es sich um einen 8 AWG-Kupferdraht (VW-1) und einer Mindesttemperatur von 32° handeln.                                                                         |
| MISE EN GARDE | Pour le circuit d'alimentation C.C du système, assurez-vous de la présence d'un disjoncteur de 30 ampères, minimum -48 V C.C., double coupure, sur l'entrée vers le bloc d'alimentation. Les câbles d'alimentation pour le produit doivent être en fils de cuivre, 8 AWG (American Wire Gauge), marqués VW-1 et classés 90 degrés Celsius.                                                        |
| PRECAUCIÓN    | Para el circuito de entrada de CC al sistema (BigIron RX-4, -8, y -16), verifique que existe un cortacircuitos catalogado de 30 amperios, como mínimo, -48 VCC, bipolar, en la entrada al bloque terminal. El cableado de entrada para la conexión al producto deberá ser de cable de cobre catalogado, 8 AWG, marcado con VW-1, y tener una capacidad nominal mínima para 90 grados centígrados. |

|               |                                                                                                                                                                                                                                                |
|---------------|------------------------------------------------------------------------------------------------------------------------------------------------------------------------------------------------------------------------------------------------|
| CAUTION       | Carefully follow the mechanical guides on each side of the power supply slot and make sure the power supply is properly inserted in the guides. Never insert the power supply upside down.                                                     |
| VORSICHT      | Beachten Sie mechanischen Führungen an jeder Seite des Netzteils, das ordnungsgemäß in die Führungen gesteckt werden muss. Das Netzteil darf niemals umgedreht eingesteckt werden.                                                             |
| MISE EN GARDE | Suivez attentivement les repères mécaniques de chaque côté du slot du bloc d'alimentation et assurez-vous que le bloc d'alimentation est bien inséré dans les repères. N'insérez jamais le bloc d'alimentation à l'envers.                     |
| PRECAUCIÓN    | Siga cuidadosamente las guías mecánicas de cada lado de la ranura del suministro de energía y verifique que el suministro de energía está insertado correctamente en las guías. No inserte nunca el suministro de energía de manera invertida. |

|         |                                                                                                                                                               |
|---------|---------------------------------------------------------------------------------------------------------------------------------------------------------------|
| CAUTION | Be sure not to exceed the minimum recommended bend radius for the cables: 2 in. for MRJ-21 cables, and 1.5 in. for Category 5 (RJ-45) and fiber-optic cables. |
|---------|---------------------------------------------------------------------------------------------------------------------------------------------------------------|

## B Caution statements

|               |                                                                                                                                                                                                                                                                                                                                                                                                                                |
|---------------|--------------------------------------------------------------------------------------------------------------------------------------------------------------------------------------------------------------------------------------------------------------------------------------------------------------------------------------------------------------------------------------------------------------------------------|
| CAUTION       | Do not add or remove a flash card while a file operation involving the flash card's slot is in progress. Doing so can result in corruption of the flash card. If this occurs, you may need to reformat the flash card to make it usable again. Reformatting the card erases all data stored on the card.                                                                                                                       |
| VORSICHT      | Eine Flash-Karte darf nur dann eingesteckt oder herausgenommen werden, wenn keine Dateifunktion läuft, die der Flash-Karte bedarf. Wenn dies nicht beachtet wird, kann dies zur Korruption der Flash-Karte führen. Die Karte kann dann erst nach Neuformatierung wieder benutzt werden. Bei Neuformatierung gehen alle auf der Karte gespeicherten Daten verloren.                                                             |
| MISE EN GARDE | N'ajoutez pas ou ne supprimez pas une carte mémoire au cours d'une opération de fichier dans laquelle le slot de carte mémoire est impliqué. Vous risquez sinon de corrompre la carte mémoire. Si cela se produit, vous devrez peut-être reformater la carte mémoire pour qu'elle soit à nouveau utilisable. Le reformatage de la carte efface toutes les données qui y sont stockées.                                         |
| PRECAUCIÓN    | No añada ni quite una tarjeta flash mientras una operación de archivo que conlleve el uso de una ranura de tarjeta flash se encuentre en uso. De hacerlo así se podría dar lugar a la corrupción de la tarjeta flash. Si esto ocurriera, podría ser necesario que vuelva a formatear la tarjeta flash para hacer que vuelva sea utilizable. Cuando se formatea la tarjeta se borran todos los datos almacenados en la tarjeta. |

|               |                                                                                                                                  |
|---------------|----------------------------------------------------------------------------------------------------------------------------------|
| CAUTION       | Do not install the device in an environment where the operating ambient temperature might exceed 40° C (104° F).                 |
| VORSICHT      | Das Gerät darf nicht in einer Umgebung mit einer Umgebungsbetriebstemperatur von über 40° C (104° F) installiert werden.         |
| MISE EN GARDE | N'installez pas le dispositif dans un environnement où la température d'exploitation ambiante risque de dépasser 40° C (104° F). |
| PRECAUCIÓN    | No instale el instrumento en un entorno en el que la temperatura ambiente de operación pueda exceder los 40° C (104° F).         |

|               |                                                                                                                                                                                                                                                                                                                                                                                                                                                                                                                                                 |
|---------------|-------------------------------------------------------------------------------------------------------------------------------------------------------------------------------------------------------------------------------------------------------------------------------------------------------------------------------------------------------------------------------------------------------------------------------------------------------------------------------------------------------------------------------------------------|
| CAUTION       | Ensure that the device does not overload the power circuits, wiring, and over-current protection. To determine the possibility of overloading the supply circuits, add the ampere (amp) ratings of all devices installed on the same circuit as the device. Compare this total with the rating limit for the circuit. The maximum ampere ratings are usually printed on the devices near the input power connectors.                                                                                                                            |
| VORSICHT      | Stromkreise, Verdrahtung und Überlastschutz dürfen nicht durch das Gerät überbelastet werden. Addieren Sie die Nennstromleistung (in Ampere) aller Geräte, die am selben Stromkreis wie das Gerät installiert sind. Somit können Sie feststellen, ob die Gefahr einer Überbelastung der Versorgungsstromkreise vorliegt. Vergleichen Sie diese Summe mit der Nennstromgrenze des Stromkreises. Die Höchstnennströme (in Ampere) stehen normalerweise auf der Geräterückseite neben den Eingangsstromanschlüssen.                                |
| MISE EN GARDE | Assurez-vous que le dispositif ne risque pas de surcharger les circuits d'alimentation, le câblage et la protection de surintensité. Pour déterminer le risque de surcharge des circuits d'alimentation, additionnez l'intensité nominale (ampères) de tous les dispositifs installés sur le même circuit que le dispositif en question. Comparez alors ce total avec la limite de charge du circuit. L'intensité nominale maximum en ampères est généralement imprimée sur chaque dispositif près des connecteurs d'entrée d'alimentation.     |
| PRECAUCIÓN    | Verifique que el instrumento no sobrecargue los circuitos de corriente, el cableado y la protección para sobrecargas. Para determinar la posibilidad de sobrecarga en los circuitos de suministros, añada las capacidades nominales de corriente (amp) de todos los instrumentos instalados en el mismo circuito que el instrumento. Compare esta suma con el límite nominal para el circuito. Las capacidades nominales de corriente máximas están generalmente impresas en los instrumentos, cerca de los conectores de corriente de entrada. |

|               |                                                                                                                                           |
|---------------|-------------------------------------------------------------------------------------------------------------------------------------------|
| CAUTION       | Make sure the air flow around the front, sides, and back of the device is not restricted.                                                 |
| VORSICHT      | Stellen Sie sicher, dass an der Vorderseite, den Seiten und an der Rückseite der Luftstrom nicht behindert wird.                          |
| MISE EN GARDE | Vérifiez que rien ne restreint la circulation d'air devant, derrière et sur les côtés du dispositif et qu'elle peut se faire librement.   |
| PRECAUCIÓN    | Asegúrese de que el flujo de aire en las inmediaciones de las partes anterior, laterales y posterior del instrumento no esté restringido. |

|               |                                                                                                                                                                                                 |
|---------------|-------------------------------------------------------------------------------------------------------------------------------------------------------------------------------------------------|
| CAUTION       | Make sure the flash card is empty or does not contain files you want to keep. Formatting a flash card completely erases all files on the card.                                                  |
| VORSICHT      | Stellen Sie sicher, dass die Flash-Karte leer ist oder keine Dateien auf ihr gespeichert sind, die Sie behalten möchten. Die Formattierung einer Flash-Karte löscht alle Dateien auf der Karte. |
| MISE EN GARDE | Vérifiez que la carte mémoire est vide ou ne contient pas de fichiers que vous voulez conserver. Le reformatage de la carte mémoire efface tous les fichiers qui s'y trouvent.                  |
| PRECAUCIÓN    | Verifique que la tarjeta flash esté vacía o que no contenga archivos que desee conservar. Al formatear una tarjeta flash todos los archivos de ésta se borran.                                  |

|               |                                                       |
|---------------|-------------------------------------------------------|
| CAUTION       | Never leave tools inside the chassis.                 |
| VORSICHT      | Lassen Sie keine Werkzeuge im Chassis zurück.         |
| MISE EN GARDE | Ne laissez jamais d'outils à l'intérieur du châssis.  |
| PRECAUCIÓN    | No deje nunca herramientas en el interior del chasis. |

## B Caution statements

|               |                                                                                                                                                                                                                                                                                                                       |
|---------------|-----------------------------------------------------------------------------------------------------------------------------------------------------------------------------------------------------------------------------------------------------------------------------------------------------------------------|
| CAUTION       | Once you start the formatting process, you cannot stop it. Even if you enter CTRL-C to stop the CLI output and a new prompt appears, the formatting continues. Make sure you want to format the card before you enter the command.                                                                                    |
| VORSICHT      | Wenn Sie mit dem Formattieren beginnen, können Sie diesen Prozess nicht anhalten. Selbst wenn zum Anhalten der CLI-Ausgabe Strg-C drücken und eine neue Aufforderung gezeigt wird, wird mit dem Formattieren fortgefahren. Stellen Sie sicher, dass Sie die Karte formattieren wollen, bevor Sie den Befehl eingeben. |
| MISE EN GARDE | Une fois le processus de formatage commencé, vous ne pouvez pas l'interrompre. Même si vous appuyez sur CTRL-C pour arrêter la sortie CLI et si une nouvelle invite apparaît, le formatage continue. Soyez bien sûr de vouloir formater la carte avant d'entrer la commande.                                          |
| PRECAUCIÓN    | Una vez que empiece con el proceso de formateado, no se puede detener. Incluso si pulsa CTRL-C para detener la salida de CLI y aparece un nuevo indicador, el formateado continuará. Esté seguro que desea formatear la tarjeta antes de introducir el comando.                                                       |

|               |                                                                                                                                                                                                                                                                                                                                                                                                                                        |
|---------------|----------------------------------------------------------------------------------------------------------------------------------------------------------------------------------------------------------------------------------------------------------------------------------------------------------------------------------------------------------------------------------------------------------------------------------------|
| CAUTION       | Use the erase startup-config command only for new systems. If you enter this command on a system you have already configured, the command erases the configuration. If you accidentally do erase the configuration on a configured system, enter the write memory command to save the running configuration to the startup-config file.                                                                                                |
| VORSICHT      | Verwenden Sie den Befehl "Erase startup-config" (Löschen Startup-Konfig) nur für neue Systeme. Wenn Sie diesen Befehl in ein bereits konfiguriertes System eingeben, löscht der Befehl die Konfiguration. Falls Sie aus Versehen die Konfiguration eines bereits konfigurierten Systems löschen, geben Sie den Befehl "Write Memory" (Speicher schreiben) ein, um die laufende Konfiguration in der Startup-Konfig-Datei zu speichern. |
| MISE EN GARDE | N'utilisez la commande erase startup-config que pour les nouveaux systèmes. Si vous entrez cette commande sur un système que vous avez déjà configuré, elle efface la configuration. Si vous effacez la configuration par accident sur un système configuré, entrez la commande write memory pour enregistrer la configuration actuelle dans le fichier startup-config.                                                                |
| PRECAUCIÓN    | Use el comando erase startup-config (borrar configuración de inicio) para sistemas nuevos solamente. Si usted introduce este comando en un sistema que ya ha configurado, el comando borrará la configuración. Si usted borra accidentalmente la configuración en un sistema ya configurado, introduzca el comando write memory (escribir memoria) para guardar la configuración en ejecución en el archivo startup-config.            |

|               |                                                                                                                                                                                                                                                  |
|---------------|--------------------------------------------------------------------------------------------------------------------------------------------------------------------------------------------------------------------------------------------------|
| CAUTION       | Removal of BigIron RX-32 rear fan modules allows access to bus bars and backplane. Avoid contact with these parts. There are hazardous energy levels at these locations.                                                                         |
| VORSICHT      | Durch die Entfernung der rückwärtigen BigIron RX-32 Ventilatormodule wird der Zugang zu den Sammelschienen und der Rückwandplatine ermöglicht. Kontakt mit diesen Teilen vermeiden. An diesen Stellen liegen gefährliche Stromstärken an.        |
| MISE EN GARDE | La dépose des modules de ventilation en face arrière du BigIron RX-32 permet d'accéder à la distribution électrique et au fond de panier. Éviter tout contact avec ces éléments, car les tensions électriques dans cette zone sont très élevées. |
| PRECAUCIÓN    | El desmontaje de los módulos del ventilador trasero del sistema BigIron RX-32 permite el acceso a las barras del bus y a la placa posterior. Evite el contacto con estas piezas. Hay niveles peligrosos de energía en tales lugares.             |

|               |                                                                                                                                                                                                         |
|---------------|---------------------------------------------------------------------------------------------------------------------------------------------------------------------------------------------------------|
| CAUTION       | To avoid overheating of the BigIron RX-16 chassis, remove only one fan assembly at a time, and replace it promptly. Do not remove all fans from the chassis at one time.                                |
| VORSICHT      | Es darf nur ein Ventilatorblech zur Zeit entfernt werden, um ein Überhitzen des BigIron RX-16 und -32 chassis Gehäuses zu vermeiden. Es dürfen nicht beide Ventilatorbleche auf einmal entfernt werden. |
| MISE EN GARDE | Pour éviter la surchauffe du châssis des BigIron RX-16 et BigIron RX-32, n'enlever qu'un seul boîtier de ventilateur à la fois. Ne pas enlever les deux boîtiers du châssis en même temps.              |
| PRECAUCIÓN    | Para evitar el sobrecalentamiento del chasis BigIron RX-16 y -32, desmonte solamente una bandeja de ventilador a la vez. No retire las dos bandejas de ventilador del chasis a la vez.                  |

|         |                                                                                                                                                                                        |
|---------|----------------------------------------------------------------------------------------------------------------------------------------------------------------------------------------|
| CAUTION | If hot removing or inserting a module, please allow a minimum of two seconds after a module (or power supply or fan tray) has been removed before inserting a module in the same slot. |
|---------|----------------------------------------------------------------------------------------------------------------------------------------------------------------------------------------|

|               |                                                                                                                                                                |
|---------------|----------------------------------------------------------------------------------------------------------------------------------------------------------------|
| CAUTION       | Use a separate branch circuit for each AC power cord, which provides redundancy in case one of the circuits fails.                                             |
| VORSICHT      | Es empfiehlt sich die Installation eines separaten Stromkreisweiges für jede Wechselstrom-Elektroschnur als Redundanz im Fall des Ausfalls eines Stromkreises. |
| MISE EN GARDE | Utilisez un circuit de dérivation différent pour chaque cordon d'alimentation C.A. Ainsi, il y aura un circuit redondant en cas de panne d'un des circuits.    |
| PRECAUCIÓN    | Use un circuito derivado separado para cada cordón de alimentación de CA, con lo que se proporcionará redundancia en caso de que uno de los circuitos falle.   |

|               |                                                                                                                                                                                                                                                                                |
|---------------|--------------------------------------------------------------------------------------------------------------------------------------------------------------------------------------------------------------------------------------------------------------------------------|
| CAUTION       | If you do not install a module in a slot, you must keep the slot blank in place. If you run the chassis with an uncovered slot, the system may overheat. Tighten the screws that secure the slot blanks so that they remain in place when removing adjacent panels or modules. |
| VORSICHT      | Falls kein Modul im Steckplatz installiert wird, muss die Steckplatztafel angebracht werden. Wenn ein Steckplatz nicht abgedeckt wird, läuft das System heiß.                                                                                                                  |
| MISE EN GARDE | Si vous n'installez pas de module dans un slot, vous devez laisser le panneau du slot en place. Si vous faites fonctionner le châssis avec un slot découvert, le système surchauffera.                                                                                         |
| PRECAUCIÓN    | Si no instala un módulo en la ranura, deberá mantener el panel de ranuras en su lugar. Si pone en funcionamiento el chasis con una ranura descubierta, el sistema sufrirá sobrecalentamiento.                                                                                  |

## B Danger notices

|               |                                                                                                                                                                                                                                                                                                                                                                         |
|---------------|-------------------------------------------------------------------------------------------------------------------------------------------------------------------------------------------------------------------------------------------------------------------------------------------------------------------------------------------------------------------------|
| CAUTION       | All devices with AC power sources (BigIron RX-32 only) are intended for installation in restricted access areas only. A restricted access area is a location where access can be gained only by service personnel through the use of a special tool, lock and key, or other means of security.                                                                          |
| VORSICHT      | Alle Geräte mit Wechselstromquellen (BigIron RX-32 nur) sind nur zur Installation in Sperrbereichen bestimmt. Ein Sperrbereich ist ein Ort, zu dem nur Wartungspersonal mit einem Spezialwerkzeug, Schloss und Schlüssel oder einer anderen Schutzvorrichtung Zugang hat.                                                                                               |
| MISE EN GARDE | Tous les équipements dotés de sources d'alimentation électrique secteur (BigIron RX-32 uniquement) sont destinés à être installés uniquement dans des zones à accès réglementé. Une zone à accès réglementé est une zone dont l'accès n'est possible qu'au personnel de service utilisant un verrou, une clé ou un outil spécial, ou d'autres moyens de sécurité.       |
| PRECAUCIÓN    | Todos aquellos dispositivos con fuentes de alimentación de CA (BigIron RX-32 solamente) están diseñados para su instalación en zonas de acceso restringido solamente. Una zona de acceso restringido es un lugar al que sólo puede acceder personal de mantenimiento haciendo uso de una herramienta especial, una llave y un candado, o algún otro medio de seguridad. |

|               |                                                                                                                                                                                                                                                                                                                                                                                                                                                                                               |
|---------------|-----------------------------------------------------------------------------------------------------------------------------------------------------------------------------------------------------------------------------------------------------------------------------------------------------------------------------------------------------------------------------------------------------------------------------------------------------------------------------------------------|
| CAUTION       | For a BigIron RX-32 AC system, use a ground wire of at least 6 American Wire Gauge (AWG). The ground wire should have an agency-approved crimped connector (provided with the chassis) attached to one end, with the other end attached to building ground. The connector must be crimped with the proper tool, allowing it to be connected to both ground screws on the enclosure.                                                                                                           |
| VORSICHT      | Für ein Wechselstromsystem BigIron RX-32 ist ein Erdleiter von mindestens 6 AWG (amerikanische Norm für Drahtquerschnitte) zu verwenden. An einem Ende des Erdleiters sollte ein geprüfter gecrimpter Anschluss (mit Chassis bereitgestellt) angebracht sein. Das andere Ende sollte an der Gebäudeerdung angeschlossen werden. Der Anschluss muss mit dem richtigen Werkzeug gecrimpt werden, so dass er an beiden Erdungsschrauben am Gehäuse angeschlossen werden kann.                    |
| MISE EN GARDE | Pour un système à alimentation secteur BigIron RX-32, utiliser un câble de mise à la terre de calibre AWG 6 (13 mm <sup>2</sup> ) minimum. Ce fil de terre doit être équipé d'un côté d'un connecteur à sertir agréé (fourni avec le châssis), et l'autre extrémité doit être reliée à la terre du bâtiment. Ce connecteur doit être serti à l'aide de l'outil approprié afin d'être raccordé aux deux vis de mise à la terre du boîtier.                                                     |
| PRECAUCIÓN    | Para un sistema de CA BigIron RX-32, utilice un conductor de tierra de al menos 6 CAE (Calibre de Alambre Estadounidense, American Wire Gauge o AWG en sus siglas en inglés). El conductor de tierra debe tener un conector rizado homologado (suministrado con el chasis) acoplado a un extremo, y el otro extremo debe estar conectado a la tierra del edificio. El conector debe rizarse con la herramienta apropiada, de manera que se conecte a los dos tornillos de tierra del recinto. |

## Danger notices

A Danger notice calls your attention to a possible hazard that can cause injury or death. The following are the Danger notices used in this manual.

"Gefahr" weist auf eine mögliche Gefährdung hin, die zu Verletzungen oder Tod führen können. Sie finden die folgenden Warnhinweise in diesem Handbuch.

Un "danger" attire votre attention sur un risque possible de blessure ou de décès. Ci-dessous, vous trouverez les Dangers utilisés dans ce manuel.



Una peligro le llama la atención sobre cualquier peligro posible que pueda ocasionar daños personales o la muerte. A continuación se dan las Peligros utilizadas en este manual.

|               |                                                                                                       |
|---------------|-------------------------------------------------------------------------------------------------------|
| Danger notice | The procedures in this manual are for qualified service personnel.                                    |
| Gefahr        | Die Installation und Entfernung der Einheit dürfen nur von qualifiziertem Personal ausgeführt werden. |
| Danger        | L'installation et la dépose de l'unité doivent être confiées uniquement à du personnel qualifié.      |
| Peligro       | La instalación y desinstalación de la unidad debe llevarse a cabo solamente por personal cualificado. |

|               |                                                                                                                                                                                         |
|---------------|-----------------------------------------------------------------------------------------------------------------------------------------------------------------------------------------|
| Danger notice | Before beginning the installation, refer to the precautions in " <a href="#">Power precautions</a> " on page 26.                                                                        |
| Gefahr        | Vor der Installation siehe Vorsichtsmaßnahmen unter " Power Precautions " (Vorsichtsmaßnahmen in Bezug auf elektrische Ablagen) auf den Seiten <a href="#">page 26</a> .                |
| Danger        | Avant de commencer l'installation, consultez les précautions décrites dans " Power Precautions " (Précautions quant à l'alimentation), <a href="#">page 26</a> .                        |
| Peligro       | Antes de comenzar la instalación, consulte las precauciones en la sección " Power Precautions" (Precauciones sobre corriente) que se encuentra en las páginas <a href="#">page 26</a> . |

|               |                                                                                                                                   |
|---------------|-----------------------------------------------------------------------------------------------------------------------------------|
| Danger notice | Disconnect the power cord from all power sources to completely remove power from the device.                                      |
| Gefahr        | Ziehen Sie das Stromkabel aus allen Stromquellen, um sicherzustellen, dass dem Gerät kein Strom zugeführt wird.                   |
| Danger        | Débranchez le cordon d'alimentation de toutes les sources d'alimentation pour couper complètement l'alimentation du dispositif.   |
| Peligro       | Para desconectar completamente la corriente del instrumento, desconecte el cordón de corriente de todas las fuentes de corriente. |

|               |                                                                                                                                                                                                                                                                                                                                                                                                                             |
|---------------|-----------------------------------------------------------------------------------------------------------------------------------------------------------------------------------------------------------------------------------------------------------------------------------------------------------------------------------------------------------------------------------------------------------------------------|
| Danger notice | If the installation requires a different power cord than the one supplied with the device, make sure you use a power cord displaying the mark of the safety agency that defines the regulations for power cords in your country. The mark is your assurance that the power cord can be used safely with the device.                                                                                                         |
| Gefahr        | Falls für die Installation ein anderes Stromkabel erforderlich ist (wenn das mit dem Gerät gelieferte Kabel nicht passt), müssen Sie sicherstellen, dass Sie ein Stromkabel mit dem Siegel einer Sicherheitsbehörde verwenden, die für die Zertifizierung von Stromkabeln in Ihrem Land zuständig ist. Das Siegel ist Ihre Garantie, dass das Stromkabel sicher mit Ihrem Gerät verwendet werden kann.                      |
| Danger        | Si l'installation nécessite un cordon d'alimentation autre que celui fourni avec le dispositif, assurez-vous d'utiliser un cordon d'alimentation portant la marque de l'organisation responsable de la sécurité qui définit les normes et réglementations pour les cordons d'alimentation dans votre pays. Cette marque vous assure que vous pouvez utiliser le cordon d'alimentation avec le dispositif en toute sécurité. |
| Peligro       | Si la instalación requiere un cordón de corriente distinto al que se ha suministrado con el instrumento, verifique que usa un cordón de corriente que venga con la marca de la agencia de seguridad que defina las regulaciones para cordones de corriente en su país. Esta marca será su garantía de que el cordón de corriente puede ser utilizado con seguridad con el instrumento.                                      |

## B Danger notices

|               |                                                                                                                                                                                                      |
|---------------|------------------------------------------------------------------------------------------------------------------------------------------------------------------------------------------------------|
| Danger notice | Make sure that the power source circuits are properly grounded, then use the power cord supplied with the device to connect it to the power source.                                                  |
| Gefahr        | Stellen Sie sicher, dass die Stromkreise ordnungsgemäß geerdet sind. Benutzen Sie dann das mit dem Gerät gelieferte Stromkabel, um es an die Stromquelle anzuschließen.                              |
| Danger        | Vérifiez que les circuits de sources d'alimentation sont bien mis à la terre, puis utilisez le cordon d'alimentation fourni avec le dispositif pour le connecter à la source d'alimentation.         |
| Peligro       | Verifique que circuitos de la fuente de corriente están conectados a tierra correctamente; luego use el cordón de potencia suministrado con el instrumento para conectarlo a la fuente de corriente. |

|               |                                                                                                                                                                                                    |
|---------------|----------------------------------------------------------------------------------------------------------------------------------------------------------------------------------------------------|
| Danger notice | Make sure the rack or cabinet housing the device is adequately secured to prevent it from becoming unstable or falling over.                                                                       |
| Gefahr        | Stellen Sie sicher, dass das Gestell oder der Schrank für die Unterbringung des Geräts auf angemessene Weise gesichert ist, so dass das Gestell oder der Schrank nicht wackeln oder umfallen kann. |
| Danger        | Vérifiez que le bâti ou le support abritant le dispositif est bien fixé afin qu'il ne devienne pas instable ou qu'il ne risque pas de tomber.                                                      |
| Peligro       | Verifique que el bastidor o armario que alberga el instrumento está asegurado correctamente para evitar que pueda hacerse inestable o que caiga.                                                   |

|               |                                                                                                                                                                                                                                                           |
|---------------|-----------------------------------------------------------------------------------------------------------------------------------------------------------------------------------------------------------------------------------------------------------|
| Danger notice | Mount the devices you install in a rack or cabinet as low as possible. Place the heaviest device at the bottom and progressively place lighter devices above.                                                                                             |
| Gefahr        | Montieren Sie die Geräte im Gestell oder Schrank so tief wie möglich. Platzieren Sie das schwerste Gerät ganz unten, während leichtere Geräte je nach Gewicht (je schwerer desto tiefer) darüber untergebracht werden.                                    |
| Danger        | Montez les dispositifs que vous installez dans un bâti ou support aussi bas que possible. Placez le dispositif le plus lourd en bas et le plus léger en haut, en plaçant tous les dispositifs progressivement de bas en haut du plus lourd au plus léger. |
| Peligro       | Monte los instrumentos que instale en un bastidor o armario lo más bajos posible. Ponga el instrumento más pesado en la parte inferior y los instrumentos progresivamente más livianos más arriba.                                                        |

|               |                                                                                                                                                              |
|---------------|--------------------------------------------------------------------------------------------------------------------------------------------------------------|
| Danger notice | For safety reasons, the ESD wrist strap should contain a 1 meg ohm series resistor.                                                                          |
| Gefahr        | Aus Sicherheitsgründen sollte ein EGB-Armband zum Schutz von elektronischen gefährdeten Bauelementen mit einem 1 Megaohm-Reihenwiderstand ausgestattet sein. |
| Danger        | Pour des raisons de sécurité, la dragonne ESD doit contenir une résistance de série 1 méga ohm.                                                              |
| Peligro       | Por razones de seguridad, la correa de muñeca ESD deberá contener un resistor en serie de 1 mega ohmio.                                                      |

|               |                                                                                                                                                                                                                                                                                                                                                                                                                                                                                                                                                                                                                                                                                                                     |
|---------------|---------------------------------------------------------------------------------------------------------------------------------------------------------------------------------------------------------------------------------------------------------------------------------------------------------------------------------------------------------------------------------------------------------------------------------------------------------------------------------------------------------------------------------------------------------------------------------------------------------------------------------------------------------------------------------------------------------------------|
| Danger notice | The power supplies are hot swappable, which means they can be removed and replaced while the BigIron RX Series chassis is powered on and running. However, Brocade recommends that you disconnect a power supply from its power source before removing and replacing the supply. The BigIron RX-4, -8, or -16 chassis can be running while a power supply is being removed and replaced, but the power supply itself should not be connected to a power source. Otherwise, you could be injured or the power supply or other parts of the device could be damaged.                                                                                                                                                  |
| Gefahr        | Die Wechselstrom-Netzteile können während des Betriebs des BigIron RX-Gehäuse abgenommen und ausgetauscht werden. Allerdings empfiehlt Brocade, den Stecker des Wechselstrom-Netzteils aus der Steckdose zu ziehen, bevor das Netzteil abgenommen und ausgetauscht wird. Ein Netzteil kann während des Betriebs des BigIron RX-4, -8, or -16 abgenommen und ausgetauscht werden. Allerdings sollte das Netzteil nicht an eine Stromquelle angeschlossen sein. Bei Nichtbeachtung könnte dies zu Verletzungen des Bedieners oder Beschädigung des Wechselstrom-Netzteils oder anderer Geräteteile führen.                                                                                                            |
| Danger        | Les alimentations électriques sont échangeables à chaud. Elles peuvent être déposées et remplacées pendant que le châssis BigIron RX est allumé et en cours de fonctionnement. Cependant, Brocade recommande de débrancher le bloc d'alimentation C.A. du secteur avant d'enlever ou de remplacer le bloc d'alimentation. Le châssis BigIron RX-4, BigIron RX-8 ou BigIron RX-16 peut fonctionner pendant le retrait et le remplacement d'une alimentation électrique, mais il est important que celle-ci ne soit pas raccordée à la source secteur. Faute de déconnecter l'alimentation électrique du secteur, le personnel risque d'être blessé ou d'endommager l'alimentation électrique ou d'autres composants. |
| Peligro       | Los suministros de corriente alterna pueden desmontarse y reemplazarse cuando el chasis del BigIron RX está activado y en funcionamiento. No obstante, Brocade recomienda que se desconecte el suministro de corriente alterna del tomacorriente antes de desmontar y reemplazar el suministro. El chasis BigIron RX-4, -8, ó -16 puede estar en funcionamiento cuando un suministro de corriente esté siendo desmontado y reemplazado, pero el suministro de corriente en sí no deberá estar conectado a la corriente. De lo contrario, podría sufrir daños personales o el suministro de corriente alterna u otras partes del dispositivo podrían sufrir desperfectos.                                            |

|               |                                                                            |
|---------------|----------------------------------------------------------------------------|
| Danger notice | All fiber-optic interfaces use Class 1 Lasers.                             |
| Gefahr        | Alle Glasfaser-Schnittstellen verwenden Laser der Klasse 1.                |
| Danger        | Toutes les interfaces en fibres optiques utilisent des lasers de classe 1. |
| Peligro       | Todas las interfaces de fibra óptica utilizan láser de clase 1.            |

## B Danger notices

|               |                                                                                                                                                                                                                                                                                                                                                                                                           |
|---------------|-----------------------------------------------------------------------------------------------------------------------------------------------------------------------------------------------------------------------------------------------------------------------------------------------------------------------------------------------------------------------------------------------------------|
| Danger notice | The front panel of an AC power supply includes a handle that locks the power supply in the chassis. This handle is a locking mechanism only and should not be used to lift and carry the power supply. You may sustain physical injury or harm if you attempt to lift and carry a power supply using the locking handle.                                                                                  |
| Gefahr        | Die Vorderabdeckung eines Wechselstrom-Netzteils verfügt über einen Griff, mit dem das Netzteil im Gehäuse verriegelt werden kann. Dieser Griff dient nur der Verriegelung. Mit ihm sollte das Netzteil weder angehoben noch getragen werden. Anheben und Tragen eines Netzteils mit dem Verriegelungsgriff kann zu Verletzungen führen.                                                                  |
| Danger        | Le panneau avant d'un bloc d'alimentation C.A. comprend une poignée qui permet de verrouiller le bloc d'alimentation dans le châssis. Cette poignée est un mécanisme de verrouillage uniquement, elle ne doit pas être utilisée pour soulever et transporter le châssis. Vous risquez d'être blessé si vous essayez de soulever et de transporter un bloc d'alimentation avec la poignée de verrouillage. |
| Peligro       | El panel delantero de un suministro de corriente alterna incluye un mango que bloquea el suministro de corriente al chasis. El mango es un mecanismo de bloqueo solamente y no deberá usarse para alzar ni transportar el suministro de corriente. De hacerlo así, podría sufrir daños personales.                                                                                                        |

|               |                                                                                                                                                                                                                                                                                                                                                                                                            |
|---------------|------------------------------------------------------------------------------------------------------------------------------------------------------------------------------------------------------------------------------------------------------------------------------------------------------------------------------------------------------------------------------------------------------------|
| Danger notice | A fully-populated BigIron RX-4, -8, or -16 chassis is heavy. TWO OR MORE PEOPLE ARE REQUIRED WHEN LIFTING, HANDLING, OR MOUNTING THESE DEVICES. When lifting any heavy object, lift most of the weight with your legs rather than your back. Keep your knees bent and your back nearly straight and avoid twisting your body as you lift. Balance the load evenly and be sure that your footing is secure. |
| Gefahr        | Ein voll bestücktes BigIron RX-4, -8, or -16 Gehäuse ist schwer. ZUM ANHEBEN, HANDHABEN ODER MONTIEREN DIESER GERÄTE SIND MINDESTENS ZWEI PERSONEN ERFORDERLICH.                                                                                                                                                                                                                                           |
| Danger        | Un châssis BigIron RX-4, BigIron RX-8 ou BigIron RX-16 entièrement équipé est extrêmement lourd. POUR SOULEVER, MANIPULER OU MONTER CES ÉQUIPEMENTS, DEUX PERSONNES AU MINIMUM SONT NÉCESSAIRES.                                                                                                                                                                                                           |
| Peligro       | Un chasis BigIron RX-4, -8, ó -16 muy concurrido es muy pesado. SE REQUIEREN DOS O MÁS PERSONAS CUANDO SE VAYA A ALZAR, MANEJAR O MONTAR ESTE DISPOSITIVO.                                                                                                                                                                                                                                                 |

|               |                                                                                                   |
|---------------|---------------------------------------------------------------------------------------------------|
| Danger notice | Four or more people are required to position the unpopulated BigIron RX-32 chassis into the rack. |
|---------------|---------------------------------------------------------------------------------------------------|

|               |                                                                                                                                               |
|---------------|-----------------------------------------------------------------------------------------------------------------------------------------------|
| Danger notice | The BigIron RX-32 fan assembly is heavy and will be off-balance as you remove it. Use both hands on the handle.                               |
| Gefahr        | Die BigIron RX-32-Ventilatoreinheit ist schwer und kommt aus dem Gleichgewicht, wenn sie entfernt wird. Den Griff mit beiden Händen anfassen. |
| Danger        | Le module de ventilation du BigIron RX-32 est lourd et peut déséquilibrer lors de la dépose. Tenir la poignée à l'aide des deux mains.        |
| Peligro       | La unidad del ventilador del sistema BigIron RX-32 es pesada y quedará desequilibrada al desmontarla. Agarre el asa con las dos manos.        |

|               |                                                                                                                                                  |
|---------------|--------------------------------------------------------------------------------------------------------------------------------------------------|
| Danger notice | Make sure to choose the appropriate circuit device depending on the number of AC power supplies installed in the chassis.                        |
| Gefahr        | Je nach Anzahl der Wechselstrom-Netzteile im Gehäuse muss das passende Stromgerät ausgewählt werden.                                             |
| Danger        | Assurez-vous de choisir le dispositif de circuit approprié selon le nombre de blocs d'alimentation C.A. installés dans le châssis.               |
| Peligro       | Asegúrese de que elige el dispositivo de circuitos apropiado dependiendo del número de suministros de corriente alterna instalados en el chasis. |

|               |                                                                                                                                                                                                        |
|---------------|--------------------------------------------------------------------------------------------------------------------------------------------------------------------------------------------------------|
| Danger notice | Be careful not to insert your fingers into the fan tray while removing it from the chassis. The fan may still be spinning at a high speed.                                                             |
| Gefahr        | Die Finger dürfen nicht versehentlich in das Ventilatorblech gesteckt werden, wenn dieses vom Gehäuse abgenommen wird. Der Ventilator kann sich unter Umständen noch mit hoher Geschwindigkeit drehen. |
| Danger        | Faites attention de ne pas accidentellement insérer vos doigts dans le boîtier du ventilateur lorsque vous l'enlevez du châssis. Il est possible que le ventilateur tourne encore à grande vitesse.    |
| Peligro       | Procure no insertar los dedos accidentalmente en la bandeja del ventilador cuando esté desmontando el chasis. El ventilador podría estar girando a gran velocidad.                                     |

|               |                                                                                                                                                                                                                                                       |
|---------------|-------------------------------------------------------------------------------------------------------------------------------------------------------------------------------------------------------------------------------------------------------|
| Danger notice | To prevent damage to the chassis and components, never attempt to lift the chassis using the fan or power supply handles. These handles were not designed to support the weight of the chassis.                                                       |
| Gefahr        | Alle Geräte mit Wechselstromquellen sind nur zur Installation in Sperrbereichen bestimmt. Ein Sperrbereich ist ein Ort, zu dem nur Wartungspersonal mit einem Spezialwerkzeug, Schloss und Schlüssel oder einer anderen Schutzvorrichtung Zugang hat. |
| Danger        | Pour éviter d'endommager le châssis et les composants, ne jamais tenter de soulever le châssis par les poignées du ventilateur ou de l'alimentation. Ces poignées n'ont pas été conçues pour supporter le poids du châssis.                           |
| Peligro       | Para prevenir daños al chasis y a los componentes, nunca intente levantar el chasis usando las asas de la fuente de alimentación o del ventilador. Tales asas no han sido diseñadas para soportar el peso del chasis.                                 |

## B Danger notices

|               |                                                                                                                                                                                                                                                                                                                                                                                                                            |
|---------------|----------------------------------------------------------------------------------------------------------------------------------------------------------------------------------------------------------------------------------------------------------------------------------------------------------------------------------------------------------------------------------------------------------------------------|
| Danger notice | Do not attempt to lift a fully-populated BigIron RX-32 chassis. It is extremely heavy. REMOVE THE POWER SUPPLIES AND INTERFACE MODULES FIRST (management, switch fabric, and all line cards). Use a mechanical lifting device to lift the chassis. Four or more people are required to position the unpopulated chassis into the rack.                                                                                     |
| Gefahr        | Nicht versuchen, ein vollständig beladenes BigIron RX-32 Chassis anzuheben. Es ist sehr schwer. ZUERST DIE STROMVERSORGUNGEN UND SCHNITTSTELLENMODULE ENTFERNEN (Management, Switch-Fabric und alle Line-Cards). Das Chassis mit Hilfe einer mechanischen Hebevorrichtung anheben. Mindestens vier Personen sind erforderlich, um das unbeladene Chassis im Rack zu positionieren.                                         |
| Danger        | Ne jamais tenter de soulever un châssis BigIron RX-32 entièrement équipé, car il est alors extrêmement lourd. DÉPOSER AU PRÉALABLE LES ALIMENTATIONS ÉLECTRIQUES ET LES MODULES D'INTERFACE (supervision, matrice de commutation et cartes de lignes). Pour soulever le châssis, utiliser un appareil élévateur. Quatre personnes au moins sont nécessaires pour positionner dans le rack le châssis vidé de ses éléments. |
| Peligro       | No trate de levantar un chasis BigIron RX-32 totalmente poblado. Es extremadamente pesado. QUITE PRIMERO LOS MÓDULOS DE INTERFAZ Y DE ALIMENTACIÓN (administración, matriz de conmutación, y todas las tarjetas de línea). Utilice un elevador mecánico para levantar el chasis. Hacen falta cuatro personas o más para colocar el chasis no poblado en el interior del armazón.                                           |

|               |                                                                                                            |
|---------------|------------------------------------------------------------------------------------------------------------|
| Danger notice | High Touch Current. Earth connection essential before connecting supply (BigIron RX-32).                   |
| Gefahr        | Hoher Ableitstrom. Vor Anschluss ans Netz Schutzerdung herstellen.                                         |
| Danger        | Courant de fuite élevé. Mise à la terre obligatoire avant la connexion de l'alimentation (BigIron RX-32).  |
| Peligro       | Alta tensión al tacto. La conexión a tierra es esencial antes de conectar la alimentación (BigIron RX-32). |

|               |                                                                                                                                                                                                                                                                                               |
|---------------|-----------------------------------------------------------------------------------------------------------------------------------------------------------------------------------------------------------------------------------------------------------------------------------------------|
| Danger notice | The ports labeled BITS1, BITS2 are safety extra low voltage (SELV) circuits. SELV circuits should only be connected to other SELV circuits. All interconnected equipment should be located in the same building as the unit.                                                                  |
| Gefahr        | Die Anschlüsse BITS1, BITS2 sind SELV (Safety Extra Low Voltage)- Stromkreise. SELV-Stromkreise sollten nur an andere SELV-Stromkreise angeschlossen werden. Alle mit einander verbundenen Geräte sollten sich im gleichen Gebäude wie die Einheit befinden.                                  |
| Danger        | Les ports marqués BITS1, BITS2 sont des circuits de sécurité à très basse tension (SELV). Ces circuits doivent uniquement être connectés à d'autres circuits SELV. Tous les équipements interconnectés via ces ports doivent se trouver dans le même bâtiment que l'unité.                    |
| Peligro       | Los puertos que llevan las marcas BITS1, BITS2 son circuitos de bajo voltaje de seguridad extra (SELV, por sus siglas en inglés). Los circuitos SELV sólo deben conectarse a otros circuitos SELV. Todos los equipos interconectados deben estar situados en el mismo edificio que la unidad. |

# Software Specifications

---

## IEEE compliance

The BigIron RX Series switch supports the following standards:

- 802.1d Bridging
- 802.1q VLAN Tagging
- 802.1w Rapid Spanning Tree (RSTP)
- 802.1x User Authentication
- 802.3, 10BaseT
- 802.3ad Link Aggregation
- 802.3ae 10000BaseX
- 802.3u, 100BaseTX, 100BaseFX
- 802.3z 1000BaseSX, 1000BaseLX
- 802.3x Flow Control

## RFC support

The following sections list the RFCs supported by the BigIron RX Series switch.

### General protocols

- 791 – Internet Protocol (IP)
- 792 – Internet Control Message Protocol (ICMP)
- 793 – Transmission Control Protocol (TCP)
- 783 – Trivial File Transfer Protocol (TFTP)
- 768 – User Datagram Protocol (UDP)
- 826 – Ethernet Address Resolution Protocol (ARP)
- 854, 855, and 857 – TELNET
- 894 – IP over Ethernet
- 903 – RARP
- 906 – Bootstrap loading using TFTP
- 919 – Broadcast Internet datagrams
- 920 – Domain requirements
- 922 – Broadcast Internet datagrams in the presence of subnets
- 950 – Internet standard subnetting procedure

- 951 – Bootstrap Protocol (BootP)
- 1027 – Proxy ARP
- 1042 – IP datagrams over IEEE 802 networks (for Ethernet)
- 1122 and 1123 – Requirements for Internet Hosts (switches)
- 1141 – Incremental updating of the Internet checksum
- 1256 – ICMP Router Discovery Protocol (IRDP)
- 1267 – Border Gateway Protocol version 3
- 1321 – The MD5 Message-Digest Algorithm
- 1340 – Assigned numbers (where applicable)
- 1377 – The PPP OSI Network Layer Control Protocol (OSINLCP)
- 1519 – Classless Inter-Domain Routing (CIDR): an Address Assignment and Aggregation Strategy
- 1541 and 1542 – Dynamic Host Configuration Protocol (DHCP)
- 1591 – Domain Name System Structure and Delegation
- 1812 – Requirements for IP version 4 switches
- 2131 – Dynamic Host Configuration Protocol (BootP/DHCP Helper)
- 2338 – Virtual Routing Redundancy Protocol (VRRP)

### BGP

- 1269 – Definitions of Managed Objects for the Border Gateway Protocol: Version 3
- 1745 – OSPF interactions
- 1771 – Border Gateway Protocol version 4 (BGPv4)
- 1997 – BGP Communities Attributes
- 2283 – Multiprotocol Extensions for BGP-4
- 2385 – TCP MD5 Signature Option (for BGP4)
- 2439 – BGP Route Flap Dampening
- 2796 – BGP Route Reflection
- 2842 – BGP Capability Advertisement
- 2918 – Route Refresh Capability for BGP4
- 3065 – BGP Confederations

### OSPF

- 1583 – Open Shortest Path First (OSPF)
- 1587 – OSPF Not-So-Stubby Areas (NSSAs)
- 1745 – OSPF Interactions
- 1765 – OSPF Database Overflow
- 1850 – Open Shortest Path First (OSPF) version2 MIB
- 2154 – OSPF with Digital Signatures (Password, MD-5)
- 2178 – Open shortest Path First (OSPF)



- 2328 – Open Shortest Path First (OSPF) version 2
- 2370 – OSPF Opaque LSA Option

## RIP

- 1058 – Routing Information Protocol (RIP) version 1
- 1723 – RIP version 2
- 1812 – Requirements for IP version 4 switchess

## IP Multicast

- 1075 – Distance Vector Multicast Routing Protocol
- 1112 – Internet Gateway Management Protocol (IGMP)
- 2236 – Internet Group Management Protocol (IGMP) version 2
- 2362 – IP Multicast PIM Sparse
- 2336 – IGMP v2

## Management

- 1155 – Structure and Identification of Management Information (SMI)
- 1157 – Simple Network Management Protocol (SNMP) version 1
- 1212 – Concise MIB Definitions
- 1215 – SNMP generic traps
- 1398 – Ethernet-Like MIB
- 1492 – An Access Control Protocol, Sometimes Called TACACS
- 1493 – Bridge MIB (excluding filtering of objects)
- 1657 – Definitions of Managed Objects for the Fourth Version of the Border Gateway Protocol (BGP-4) using SMIv2
- 1724 – RIP Version 2 MIB Extension
- 1757 – Remote Monitoring (RMON) Groups 1,2,3,9
- 1850 – OSPF Version 2 Management Information Base
- 1905 – Protocol Operations for Version 2 of the Simple Network Management Protocol (SNMPv2)
- 1906 – Transport Mappings for Version 2 of the Simple Network Management Protocol (SNMPv2)
- 1966 – BGP Route Reflection
- 2011 – SNMPv2 Management Information Base for the Internet Protocol using SMIv2
- 2012 – SNMPv2 Management Information Base for the Transmission Control Protocol using SMIv2
- 2013 – SNMPv2 Management Information Base for the User Datagram Protocol using SMIv2
- 2030 – Simple Network Time Protocol (SNTP)
- 2068 – HTTP

- 2096 – IP Forwarding MIB
- 2138 – Remote Authentication Dial In User Server (RADIUS)
- 2139 – RADIUS Accounting
- 2233 – The Interfaces Group MIB using SMIv2
- 2529 – Transmission of IPv6 over IPv4 Domains without Explicit Tunnels
- 2570 – Introduction to Version 3 of the Internet-standard Network Management Framework
- 2571 – An Architecture of Describing SNMP Management Frameworks
- 2572 – Message Processing and Dispatching for the Simple Network Management Protocol (SNMP)
- 2574 – User-based Security (USM) for version 3 of the Simple Network Management Protocol (SNMPv3)
- 2575 – View-based Access Control Model (VACM) for the Simple Network Management Protocol (SNMP)
- 2578 – Structure of Management Information Version 2 (SMIv2)
- 2580 – Conformance Statements for SMIv2
- 2665 – Ethernet Like MIB (incorporates RFC 1398)
- 2674– Definitions of Managed Objects for Bridges with Traffic Classes, Multicast Filtering and Virtual LAN Extensions
- 2787 – Definitions of Managed Objects for the Virtual Router Redundancy Protocol
- 2869 – RADIUS Extensions
- 2932 – IPv4 Multicast Routing MIB
- 2933 – Internet Group Management Protocol MIB
- 2934 – Protocol Independent Multicast MIB for IPv4
- 3176 – InMon Corporation's sFlow: A Method for Monitoring Traffic in Switched and Routed Networks
- 3411 – Simple Network Management Protocol (SNMP) Management Frameworks
- 3412 – Message Processing and Dispatching for the Simple Network Management Protocol (SNMP)
- 3414 – User-based Security Model (USM) for version 3 of the Simple Network Management Protocol (SNMPv3)
- 3415 – View-based Access Control Model (VACM) for the Simple Network Management Protocol (SNMP)
- 3418 – Management Information Base (MIB) for the Simple Network Management Protocol (SNMP)

## Internet drafts

In addition to the RFCs listed in [“RFC support”](#) on page 223, the BigIron RX Series switch supports the following Internet drafts:

- ietf-idmr-dvmrp version 3.05, obsoletes RFC 1075
- draft-ietf-pim-dm-05 (V1)
- draft-ietf-pim-v2-dm-03 (V2)

- The TACACS+ Protocol version 1.78

## C Internet drafts